



# Axial Piston Pumps

Series PVplus  
Variable Displacement



ENGINEERING YOUR SUCCESS.



axial piston pump variable displacement

size and displacement

rotation

variation

mounting interface

threads code

thru drive code

coupling code

seals

control

see next page →

Code	Displacement	Size
140	140 cm <sup>3</sup> /rev	4
180	180 cm <sup>3</sup> /rev	4

Code	Seals	Shaft seal
N	NBR	FKM
V	FKM	FKM
W	NBR	PTFE

Code	Rotation <sup>1)</sup>
R	Clockwise
L	Counter clockwise

<sup>1)</sup> When looked on shaft

Code	Variation
1	Standard
2	Electronic displacement sensor <sup>2)</sup>
9	Special adjustment <sup>3)</sup>

<sup>2)</sup> not for horse power control

<sup>3)</sup> requires Kxxxx number

Code	Coupling for thru drive	as single part <sup>8)</sup>
1	Single pump, no coupling	
H	with coupling 25 x 1.5 x 15, DIN 5480	MK-PVVG4K01
J	with coupling 32 x 1.5 x 20, DIN 5480	MK-PVVG4K02
K	with coupling 40 x 1.5 x 25, DIN 5480	MK-PVVG4K03
L	with coupling 50 x 2 x 24, DIN 5480	MK-PVVG4K04
Y	with coupling SAE A 9T-16/32 DP	MK-PVVG4K11
A	with coupling SAE - 11T-16/32 DP	MK-PVVG4K12
B	with coupling SAE B 13T-16/32 DP	MK-PVVG4K13
C	with coupling SAE B-B 15T-16/32 DP	MK-PVVG4K14
D	with coupling SAE C 14T-12/24 DP	MK-PVVG4K15
E	with coupling SAE C-C 17T-12/24 DP	MK-PVVG4K16
F	with coupling SAE D, E 13T-8/16 DP	MK-PVVG4K17
G	with coupling SAE F 15T-8/16 DP	MK-PVVG4K18

Code	Mounting interface		Shaft
K	metr. ISO	4-hole flange Ø160 mm	Cylindric, key
L	3019/2	4-hole flange Ø160 mm	Splined, DIN 5480
D	SAE ISO 3019/1	4-hole flange SAE D	Cylindric, key, SAE F
E		4-hole flange SAE D	Splined, SAE F, SAE D
F		4-hole flange SAE D	Cylindric, key, SAE D
G		4-hole flange SAE D	Splined, SAE D

Code	Port <sup>4)</sup>	Threads <sup>5)</sup>
1	BSPP	metric
3	UNF	UNC
4 <sup>6)</sup>	BSPP	metr. M14
8 <sup>7)</sup>	ISO 6149	metric

Code	Thru drive option	
	No adaptor for 2nd pump	
T	Single pump prepared for thru drive	
	with adaptor for 2nd pump	as single part <sup>8)</sup>
A	SAE A, Ø 82.55 mm	MK-PVVG4Axx
B	SAE B, Ø 101.6 mm	MK-PVVG4Bxx
C	SAE C, Ø 127 mm	MK-PVVG4Cxx
D	SAE D, Ø 152.4 mm	MK-PVVG4Dxx
H	metric, Ø 80 mm	MK-PVVG4Hxx
J	metric, Ø 100 mm	MK-PVVG4Jxx
K	metric, Ø 125 mm	MK-PVVG4Kxx
L	metric, Ø 160 mm	MK-PVVG4Lxx

See dimensions for details

<sup>8)</sup> to be ordered separately as single part see page 61.

<sup>4)</sup> Drain, gage and flushing ports

<sup>5)</sup> All mounting and connecting threads

<sup>6)</sup> Pressure port 1 1/4" with 4 x M14 instead of 4 x M12

<sup>7)</sup> Mounting interface, code K and L only

Standard pump is not painted. Black painted pump and ATEX (excludes electronic components) certification (Zone 2) is available as special option. For additional informations please contact Parker Hannifin.

Code			Control options
0	0	1	No control
1	0	0	With cover plate, no control function (fixed displacement pump)
M	M		Standard pressure control
M	R		Remote pressure control
M	F		Load Sensing (flow) control
M	T		Two spool LS control
Control variation			
		C	Standard version, integrated pilot valve <sup>1)</sup>
		1	NG6 interface top side for pilot valves
		2	Remote pressure port int. supply , NG6 interface <sup>2)</sup>
		3	Remote pressure port ext. supply <sup>2)</sup>
		W	With unloading function, 24VDC solenoid <sup>1)</sup>
		K	Prop.-pilot valve type PVACRE...K35 mounted
		Z	Without integrated pilot valve, NG6 interface, for mounting of accessory code PVAC*
		B	Without integrated pilot valve, without NG6 interface <sup>3)</sup>
		P	MT1 with mounted pilot valve PVAC1P <sup>2)</sup>

1) not for MT & \*Z  
2) only for MT  
3) not for MT & MM

Horse power / Torque control			
Code		Nominal HP at 1.500 rpm	Nominal torque
K		18.5 kW	120 Nm
M		22 kW	142 Nm
S		30 kW	195 Nm
T		37 kW	240 Nm
U		45 kW	290 Nm
W		55 kW	355 Nm
Y		75 kW	485 Nm
Z		90 kW	585 Nm
2		110 kW	700 Nm
Function			
	L		Horse power control with pressure control <sup>4)</sup>
	C		Horse power control with load sensing (single spool)
	Z		Horse power control with two spool LS control
Control variation			
		C	Standard version, integrated pilot valve <sup>1)</sup>
		1	NG 6 interface top side
		W	With unloading function, 24 VDC solenoid
		K	Prop.-pilot valve type PVACRE...K35 mounted
		Z	Without integrated pilot valve, NG6 interface, for mounting of accessory code PVAC* <sup>4)</sup>
		B	Without integrated pilot valve, without NG6 interface <sup>1), 4)</sup>

4) control variation Z and B without pressure pilot

Code			Control option
Electro hydraulic control <sup>5)</sup>			
F	D	V	Proportional displacement control, no pressure compensation
U	D		Proportional displacement control, with pressure compensation
Control variation			
		R	pilot operated pressure control, open NG6 interface
		K	pilot operated pressure control, proportional pilot valve type PVACRE...K35 mounted
		M	pilot operated pressure control, pressure sensor and proportional pilot valve type PVACRE...K35 mounted for pressure control and/or power control

5) further info in HY30-3254

Efficiency, power consumption  
PV140

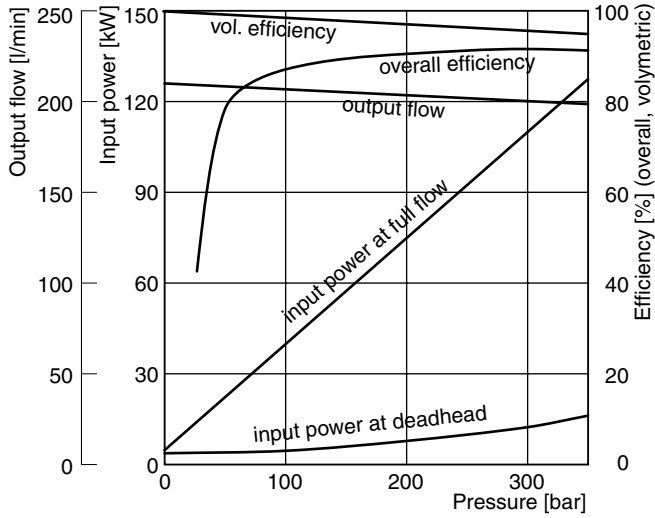

PV180

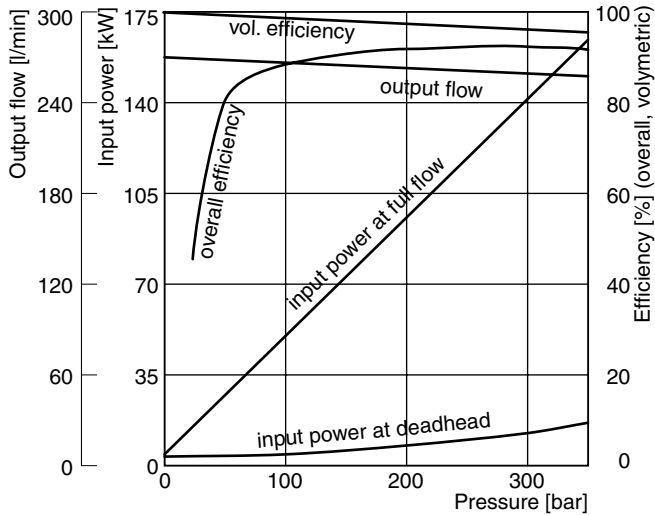

Efficiency and case drain flows PV140, PV180

The efficiency and power graphs are measured at an input speed of  $n = 1500$  rpm, a temperature of  $50\text{ }^{\circ}\text{C}$  and a fluid viscosity of  $30\text{ mm}^2/\text{s}$ .

Case drain flow and compensator control flow leave via the drain port of the pump. To the values shown are to be added 1 to 1.2 l/min, if at pilot operated compensators the control flow of the pressure pilot valve also goes through the pump.

**Please note:** The values shown below are only valid for static operation. Under dynamic conditions and at rapid compensation of the pump the volume displaced by the servo piston also leaves the case drain port. This dynamic control flow can reach up to 120 l/min! Therefore the case drain line is to lead to the reservoir at full size and without restrictions as short and direct as possible.

Case drain flows PV140-180

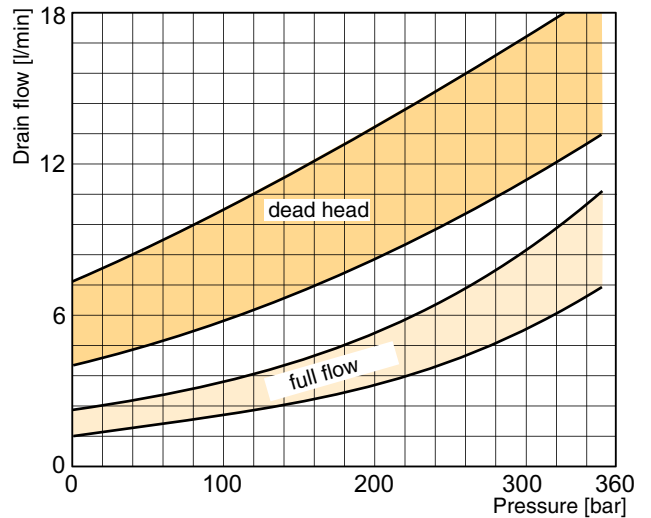

**PV 140 - 180 Metric**

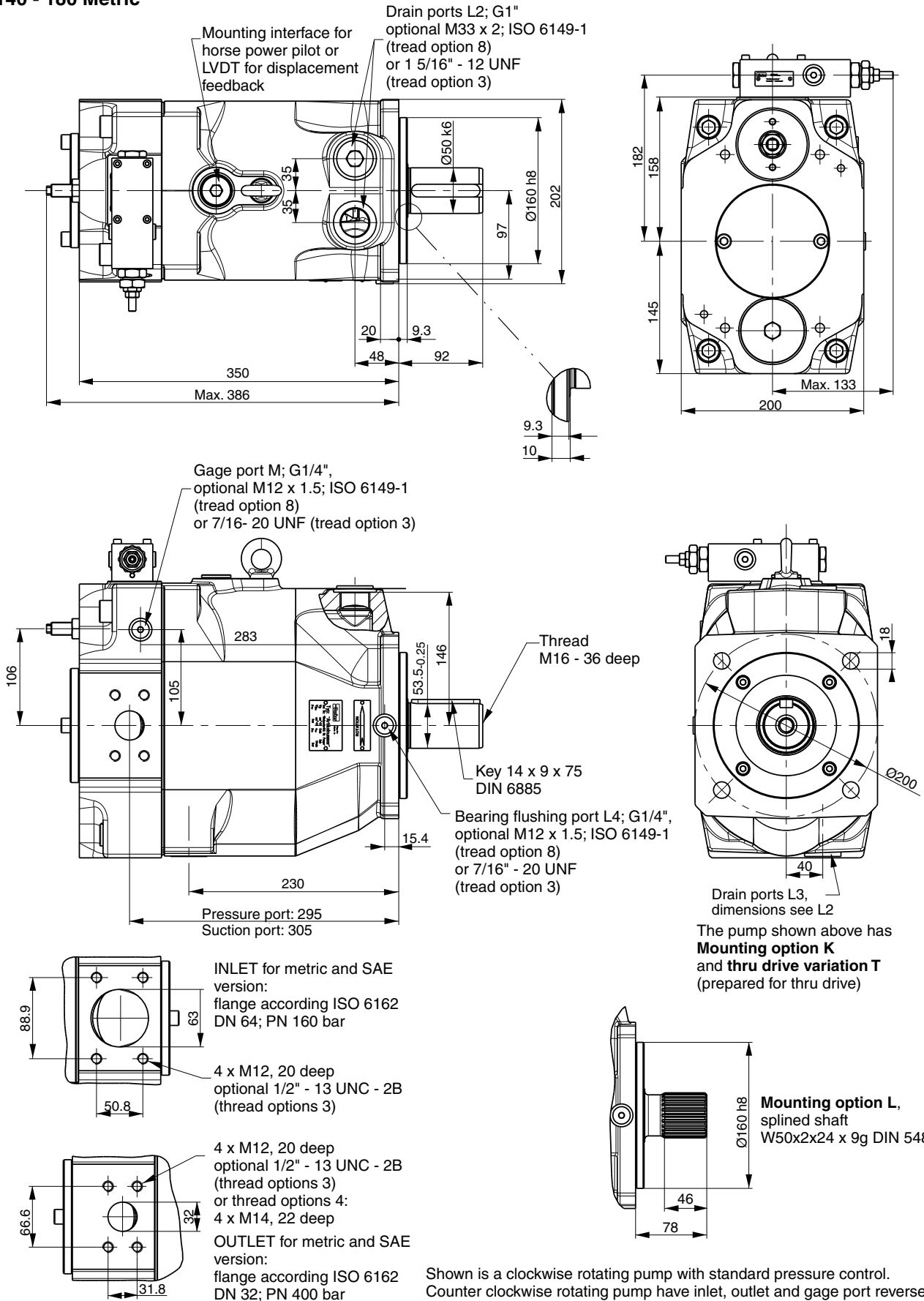

**PV 140 - 180 SAE Version**

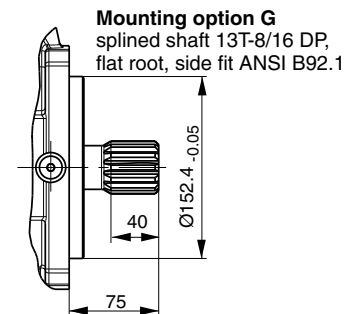
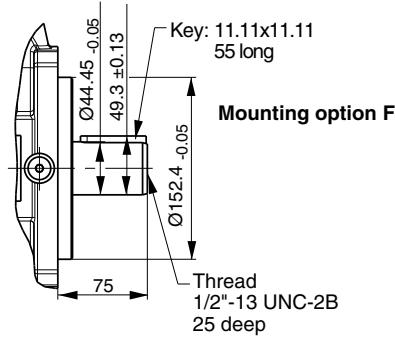
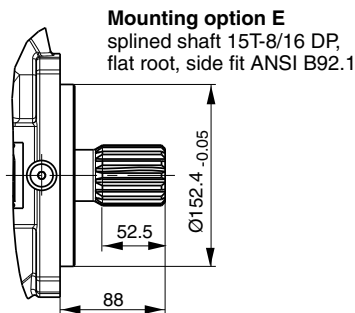
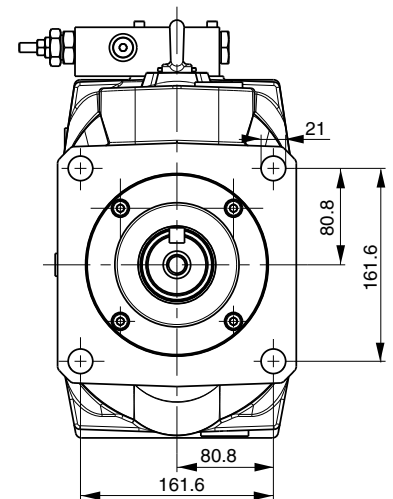
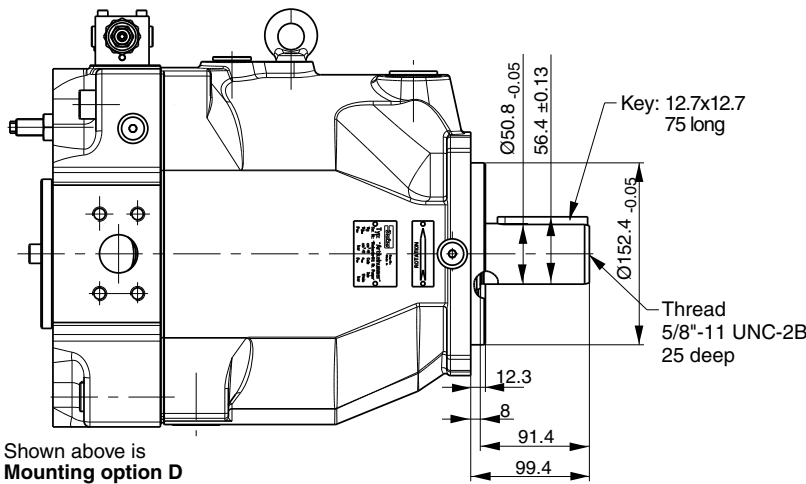

**Variation with thru drive**

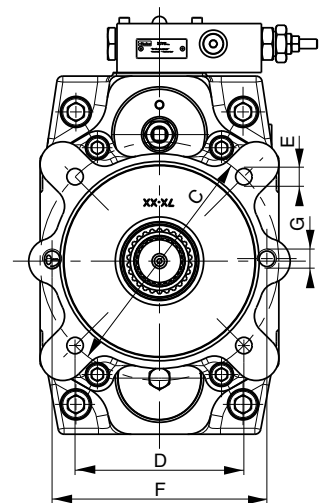
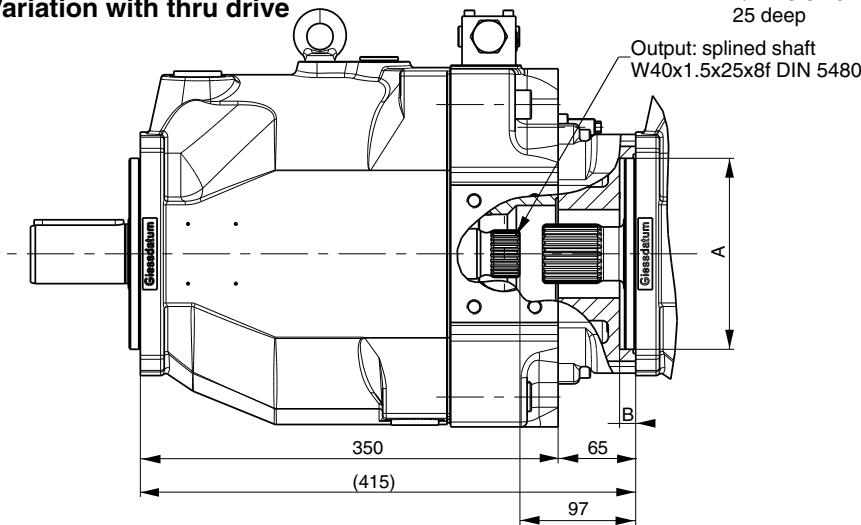

Thru drive adaptors are available with the following dimensions										
Drawing Dimension	A	B	C	D	E		F	G		Remark
					Metr	UNC		Metr	UNC	
Thru drive option										
A	82.55	8	-	-	-	-	106	M10	3/8"-16	SAE A 2-Bolt
B	101.6	11	127	89.8	M12	1/2"-13	146	M12	1/2"-13	SAE B 2/4-Bolt
C	127	13.5	162	114.6	M12	1/2"-13	181	M16	5/8"-11	SAE C 2/4-Bolt
D	152.4	13.5	228.5	161.6	M16	5/8"-11	-	-	-	SAE D 4-Bolt
H	80	8.5	103	72.8	M8	5/16"-18	109	M10	3/8"-16	2/4-Bolt
J	100	10.5	125	88.4	M10	3/8"-16	140	M12	1/2"-13	2/4-Bolt
K	125	10.5	160	113.1	M12	1/2"-13	180	M16	5/8"-11	2/4-Bolt
L	160	13.5	200	141.4	M16	5/8"-11	-	-	-	4-Bolt

**Mounting kits for multiple pumps, for second pump option**

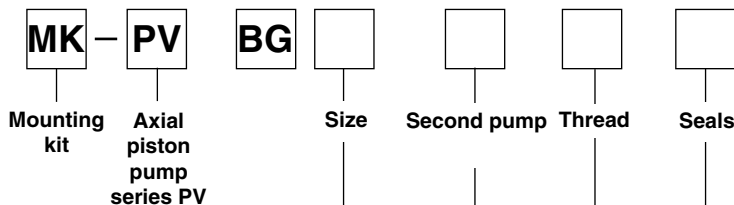

Code	Pump size
1	Pump size 1: PV016 - PV028
2	Pump size 2: PV032 - PV046
3	Pump size 3: PV063 - PV092
4	Pump size 4: PV140 - PV180
5	Pump size 5: PV270 - PV360

Code	Second pump, SAE
T	Prepared for thru drive option (plugged)
Y	SAE AA, diameter 50.8 mm
A	SAE A, diameter 82.55 mm
B	SAE B, diameter 101.6 mm
C	SAE C, diameter 127 mm
D	SAE D, diameter 152.4 mm
E	SAE E, diameter 165.1 mm
Second pump, metric	
G	Diameter 63 mm
H	Diameter 80 mm
J	Diameter 100 mm
K	Diameter 125 mm
L	Diameter 160 mm
M	Diameter 200 mm

Code	Seals
N	NBR
V	FPM

Code	Thread
M	Metric
S	SAE

Kit contains positions 30, 69, 84, 85 and 87, see spare part list

**Mounting kits for multiple pumps, couplings**

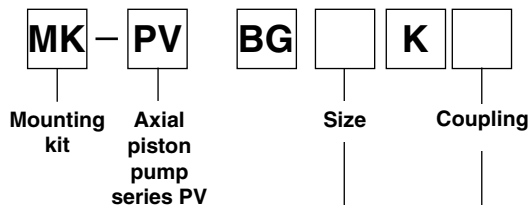

Code	Pump size
1	Pump size 1: PV016 - PV028
2	Pump size 2: PV032 - PV046
3	Pump size 3: PV063 - PV092
4	Pump size 4: PV140 - PV180
5	Pump size 5: PV270 - PV360

Code	Coupling for metric, splined shaft DIN 5480
01	N25 x 1.5 x 15
02	N32 x 1.5 x 20
03	N40 x 1.5 x 25
04	N50 x 2 x 24
05	N60 x 2 x 28
06	N70 x 3 x 22*
Coupling for SAE splined shaft flat root, side fit	
11	SAE A, 9T 16/32
12	SAE-, 11T 16/32
13	SAE B, 13T 16/32
14	SAE B-B, 15T 16/32
15	SAE C, 14T 12/24
16	SAE C-C, 17T 12/24
17	SAE D+E, 13T 8/16
18	SAE F, 15T 8/16
Coupling + adaptor for keyed shaft	
20	Diameter 12 mm
21	Diameter 16 mm
22	Diameter 18 mm

Kit contains positions 1 (and 2 for keyed shaft).

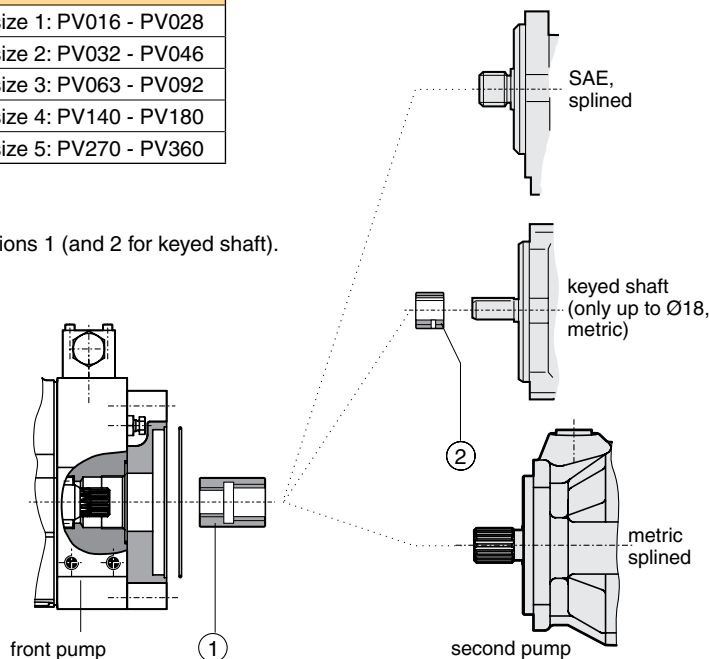

\* For PV360 only

Availability of thru drive flange and coupling please check with ordering code options per each pump size, starting at page 6

### Multiple Pump Combinations - Maximum Moment

Combinations of multiple pumps might require additional pump support to avoid a too high stress on the front mounting flange. Combinations of two PVplus pumps in the same frame size generally do not need additional support in an industrial application. For combinations of more pumps support is required.

In case of combinations of a PVplus pump with another type of pump it is recommended to calculate the moment for the combination and compare with the maximum moment in table 1 below.

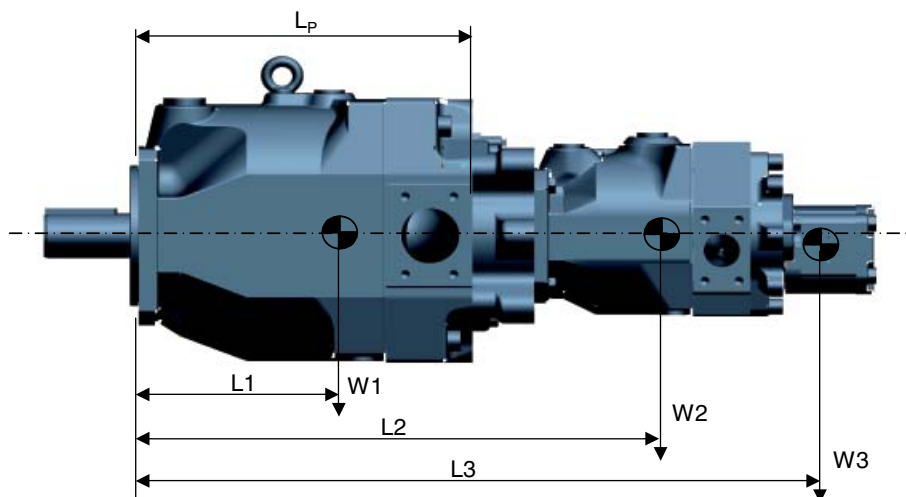

$$\text{Moment } M = (L1 \cdot W1 + L2 \cdot W2 + L3 \cdot W3 + \dots)$$

Note:

If the calculated moment M exceed the maximum moment in table 1 below, additional pump support is needed

**Table 1: Maximum Moment and Pump Dimensions**

		PV016-PV028	PV032-PV046	PV063-PV092	PV140-PV180	PV270	PV360
Maximum moment <sup>1)</sup>	[Nm]	81	151	401	591	1686	1686
Weight W	[N]	186	294	589	883	1687	1766
Distance L1	[mm to C/G]	106	119	178	184	234	238
Distance Lp	[mm]	197.5	227	287	350	472.5	477

1) at dynamic weight acceleration 10g = 98.1 m/sec<sup>2</sup>

**Table 2 Through Drive Adapter Plate Thickness [mm]**

Adapter option <sup>2)</sup>	PV016-PV028	PV032-PV046	PV063-PV092	PV140-PV180	PV270	PV360
Y	27	-	-	-	-	-
A	27	34	39	65	59	59
B	27	34	39	65	59	59
C	-	49	39	65	59	59
D	-	-	64	65	59	59
E	-	-	-	-	59	59
G	27	34	39	-	-	-
H	27	34	39	65	59	59
J	27	34	39	65	59	59
K	-	34	39	65	59	59
L	-	-	39	65	59	59
M	-	-	-	-	59	59

2) See page 6 to 17 for reference per each frame size.

<b>Maximum allowed transferable torque FRONT</b>							
Shaft code	Shaft type	Transferable torque at FRONT shaft end. [Nm]					
		PV016-028	PV032-046	PV063-092	PV140-180	PV270	PV360
<b>D</b>	SAE - Key	300	650	1850	2150	2150	4750
<b>E</b>	SAE - Spline	320	630	1700	2750	2800	8100*
<b>F</b>	SAE - Key				1200		
<b>G</b>	SAE - Spline				1700		
<b>R</b>	Metric - Key						3750
<b>T</b>	Metric - Spline						8100
<b>K</b>	Metric - Key	280	640	1200	1550	3300	3750
<b>L</b>	Metric - Spline	320	720	1500	3050	5750	8100
<b>Maximum allowed transferable torque REAR</b>							
Max. torque transmission cap. for rear mounted pump		350	520	1100	1550	3150	3250

\* DIN5480 splined

**Important notice**

The max. allowable torque of the individual shaft must not be exceeded. For 2-pump combinations there is no problem because PV series offers 100% thru torque. For 3-pump combinations (and more) the limit torque could be reached or exceeded.

Therefore it is necessary to calculate the resulting input as well as thru drive torque.



**WARNING – USER RESPONSIBILITY**

**FAILURE OR IMPROPER SELECTION OR IMPROPER USE OF THE PRODUCTS DESCRIBED HEREIN OR RELATED ITEMS CAN CAUSE DEATH, PERSONAL INJURY AND PROPERTY DAMAGE.**

This document and other information from Parker-Hannifin Corporation, its subsidiaries and authorized distributors provide product or system options for further investigation by users having technical expertise.

The user, through its own analysis and testing, is solely responsible for making the final selection of the system and components and assuring that all performance, endurance, maintenance, safety and warning requirements of the application are met. The user must analyze all aspects of the application, follow applicable industry standards, and follow the information concerning the product in the current product catalog and in any other materials provided from Parker or its subsidiaries or authorized distributors.

To the extent that Parker or its subsidiaries or authorized distributors provide component or system options based upon data or specifications provided by the user, the user is responsible for determining that such data and specifications are suitable and sufficient for all applications and reasonably foreseeable uses of the components or systems.

**Offer of Sale**

Please contact your Parker representation for a detailed "Offer of Sale".