

HRT/4-630/25 BPN

IP54



Características

Characteristics

Tensión Voltage	3 ~ 400V 50Hz
Tipo motor Motor type	4 polos 4 poles IP54 cl.F
Potencia absorbida máxima Maximum power absorbed	1,11/0,82 kW
Intensidad absorbida máxima Maximum absorbed current	2,2/1,4 A
Condensador Capacitor	
Ia/In Is/In	3,1
Temperatura del aire Air temperature	-40°C < T < +70°C
Peso Weight	20,2 kg
Código ventilador Fan code number	5700272700
Código motor Motor code number	0343642005

Dimensiones y conexiones

Dimensions and wiring

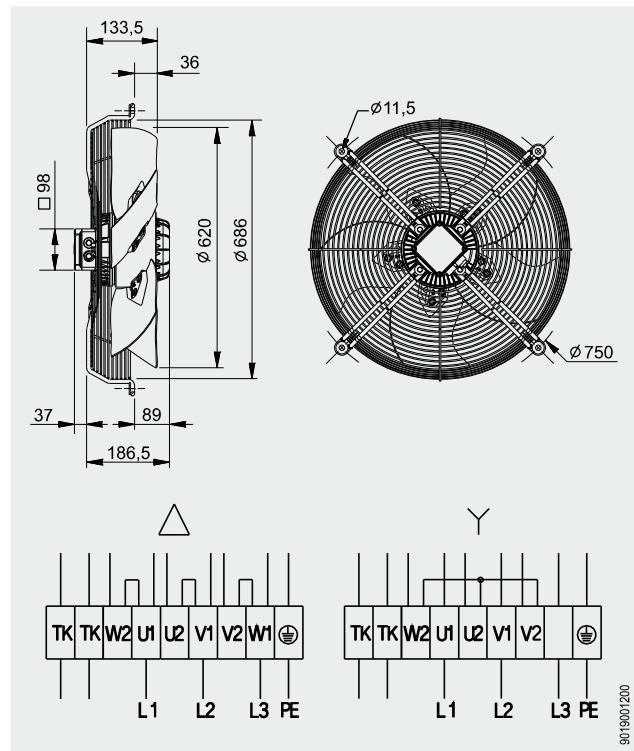

Curvas características / Performance curves (04/04/2012)

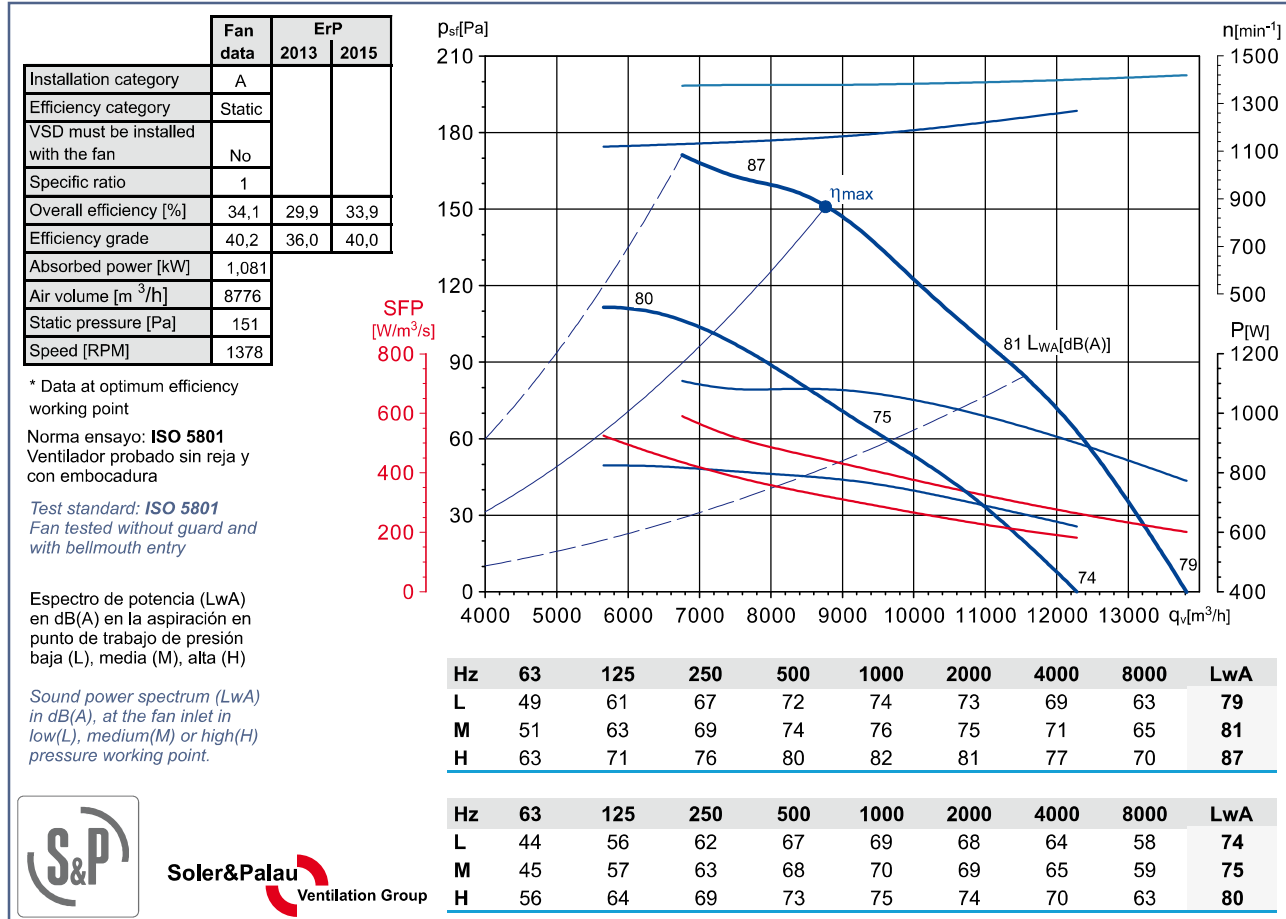

Soler&Palau
Ventilation Group