

GasMultiBloc®
Combined regulator and
safety shut-off valves
Single-stage function
Integrated bypass valve

DUNGS®
Combustion Controls

MB-D(LE) 407 - 412 B07

7.22

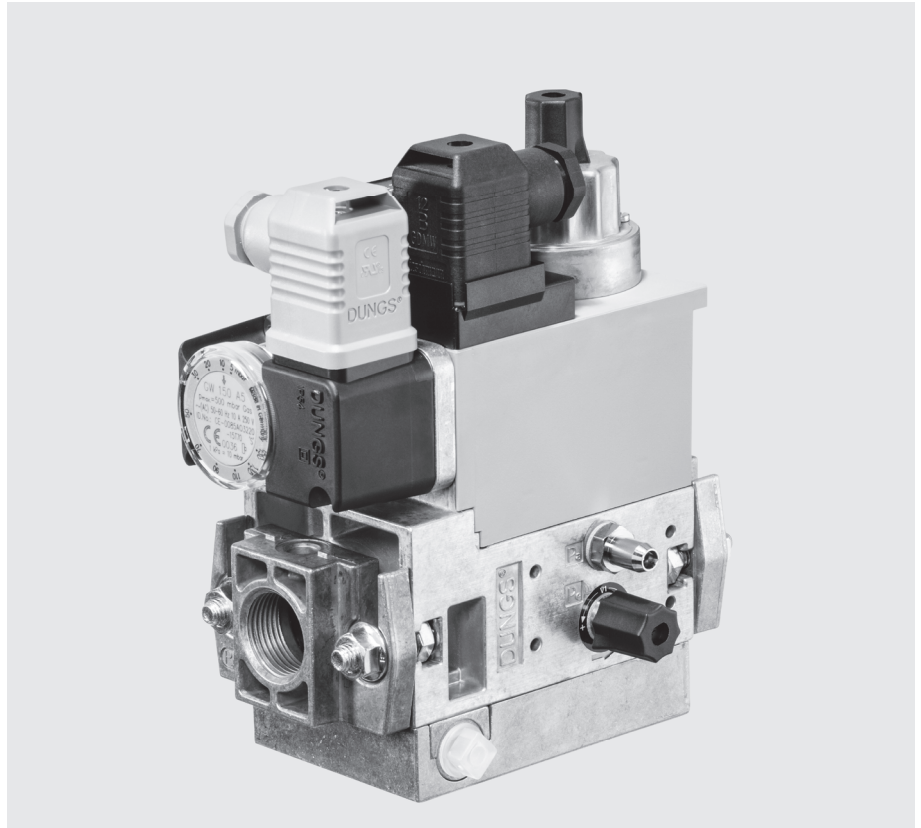

Technical description

The DUNGS GasMultiBloc® integrates filter, regulator, valves and pressure switches in one compact fitting.

- Dirt trap unit: Fine-mesh sieve
- One regulator, two main valves and one bypass valve: B07
- Two valves are fast opening, one valve is slow opening
- Solenoid valves up to 360 mbar (36 kPa) as per DIN EN 161 Class A Group 2
- Sensitive setting of output pressure by proportional regulator as per DIN EN 88 Class A Group 2
- High flow rates with low pressure drop
- DC solenoid drive interference degree N
- Main volume restrictor at valve V2, bypass restrictor at valve V3
- Hydraulic opening delay
- Flange connections with pipe threads as per ISO 7/1
- Simple mounting, compact, light-weight

The modular system permits individual solutions by using an internal bypass valve in connection with separately controlled valves, by adding a valve proving system, mini/maxi pressure switches, pressure limiters, limit switches at valve V2.

Application

The modular system permits individual solutions in gas safety and regulator engineering. Suitable for gases of families 1, 2, 3 and other neutral gaseous media.

Approvals

EU type testing certificate as per:

- EU-Gas Appliances Regulation
- EU-Pressure Equipment Directive

Approvals in other important gas consuming countries.

Specifications

Nominal diameters Flange with pipe threads as per ISO 7/1 (DIN 2999)	MB-...407 B07 Rp 1/2, 3/4 and their combinations	MB-...410/412 B07 Rp 3/4, 1, 1 1/4 and their combinations																					
Max. operating pressure	360 mbar (36 kPa)																						
Output pressure ranges	MB-... S22 p_a: 4 mbar (0.4 kPa) to 20 mbar (2 kPa) MB-... S52 p_a: 4 mbar (0.4 kPa) to 50 mbar (5 kPa)																						
Media	Gases of families 1, 2, 3 and other neutral gaseous media																						
Ambient temperature	-15 °C to +70 °C (Do not operate MB-D below 0 °C in liquid gas systems. Only suitable for gaseous liquid gas, liquid hydrocarbons destroy sealing materials.)																						
Dirt trap	Fine-mesh sieve. Replacement only possible by dismantling the fitting.																						
Pressure switches	Types GW A5, GW A2, NB A2, ÜB A2 mountable as per DIN EN 1854. For further information, refer to Datasheet GW A2 No. 215 183 and Datasheet GW A5 No. 225 901.																						
Pressure regulator	Pressure regulator compensated for residual pressure, leakproof seal when switched off by means of valve V1 as per DIN EN 88 Class A. Setpoint spring permanently installed (no spring exchange possible). A vent line above roof is not required. Internal pulse tap provided.																						
Solenoid valve V1	Valve as per DIN EN 161 Class A Group 2, fast closing, fast opening																						
Solenoid valve V2	Valve as per DIN EN 161 Class A Group 2																						
	<table border="1"> <thead> <tr> <th></th> <th colspan="2">Valve V2 design</th> <th>Main volume restrictor</th> </tr> </thead> <tbody> <tr> <td>MB</td> <td>fast closing</td> <td>fast opening</td> <td>without</td> </tr> <tr> <td>MB-D</td> <td>fast closing</td> <td>fast opening</td> <td>with</td> </tr> <tr> <td>MB-DLE</td> <td>fast closing</td> <td>slow opening</td> <td>with</td> </tr> <tr> <td>MB-LE</td> <td>fast closing</td> <td>slow opening</td> <td>without</td> </tr> </tbody> </table>				Valve V2 design		Main volume restrictor	MB	fast closing	fast opening	without	MB-D	fast closing	fast opening	with	MB-DLE	fast closing	slow opening	with	MB-LE	fast closing	slow opening	without
	Valve V2 design		Main volume restrictor																				
MB	fast closing	fast opening	without																				
MB-D	fast closing	fast opening	with																				
MB-DLE	fast closing	slow opening	with																				
MB-LE	fast closing	slow opening	without																				
Solenoid valve V3 (bypass)	Valve as per DIN EN 161 Class A Group 2, with volume restrictor																						
Measuring/ignition gas connection	For G 1/8 as per DIN ISO 228, refer to Pressure taps on page 4																						
Burner pressure monitor p _{Br}	Connection downstream of valve V2, pressure switch mountable on adapter laterally																						
Voltage / frequency	50-60 Hz ,220 - 230 V AC, -15% +10%																						
Electrical connection	Plug connection as per DIN EN 175301-803 for valves and pressure switches																						
Rating/power consumption	Refer on page 4																						
Switch-on duration	100%																						
Degree of protection	IP 54 as per IEC 529 (EN 60529)																						
Radio interference	Interference degree N																						
Materials of gas conveying parts	Housing Diaphragms, seals Solenoid drive	aluminium die casting NBR basis, Silopren (silicone rubber) steel, brass, aluminium																					
Installation position	Solenoid vertically upright or lying horizontally as well as its intermediate positions.																						
Closed position signal contact	Closed position signal contact, type K01/1 (DIN-tested), mountable on V2																						

Equipment variants GasMultiBloc®...B07 Single-stage function	407 B07	410 B07	412 B07	
MB	•	•	•	
MB-D	•	•	•	
MB-DLE	•	•	•	
MB-LE	•	•	•	
Microfilter (standard) with sieve	•	•	•	
Gas pressure switch downstream of filter	•	•	•	
downstream of valve V2 on adapter	•	•	•	
Pressure regulator	•	•	•	
Valve V1, double seat	•	•	•	
Valve V2, single seat	—	•	—	
Valve V2, double seat	•	—	•	
Valve V3, single seat with restrictor	•	•	•	
Valve opening separately	•	•	•	S...2 version
Flange Rp 1/2	•	—	—	<ul style="list-style-type: none"> • = possible (•) = on request - = not possible
Rp 3/4	•	•	•	
Rp 1	—	•	•	
Rp 1 1/4	—	•	•	

MB-...B07 version

- V1 = Valve 1
- V2 = Valve 2
- V3 = Valve 3
- 3 = Filter
- 4 = Pressure switch, optional
- 5 = Regulator

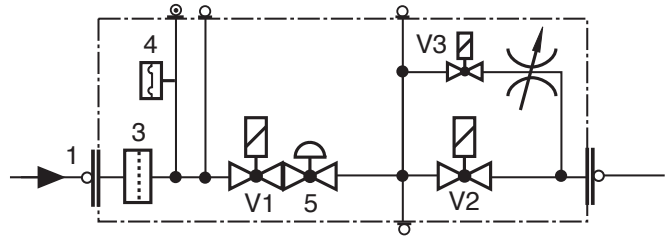

Mounting of VPS 504 valve proving system possible
 Mounting of K01/1 closed position signal contact possible

Type key of MultiBloc®

MB- XX XXX XX BOX SXX

Control of V1 and V2

0 = common
2 = separated

Outlet pressure **Inlet pressure**
 2 = 4 - 20 mbar up to 360 mbar
 5 = 4 - 50 mbar up to 360 mbar

S = Series (type-independent)

Gas train schematic diagram
 1 = two A valves for main gas + regulator
 7 = two A valves for main gas, one A valve together with V1 as internal bypass around V2 + regulator

Design type (generation) B

Construction size, nominal diameter

403 = DN 10, V2 = Single-seat valve
 405 = DN 15, V2 = Single-seat valve
 407 = DN 20, V2 = Double-seat valve
 410 = DN 25, V2 = Single-seat valve
 412 = DN 32, V2 = Double-seat valve
 415 = DN 40, V2 = Double-seat valve
 420 = DN 50, V2 = Double-seat valve

Opening behaviour + main volume restrictor

without = (MB or MB-ZR)
 -D = Main volume restrictor
 -LE = adjustable opening behaviour
 -DLE = D + LE combination

without = single stage
 ZR = double-stage with partial volume setting first stage

MultiBloc

Dimensions [mm]

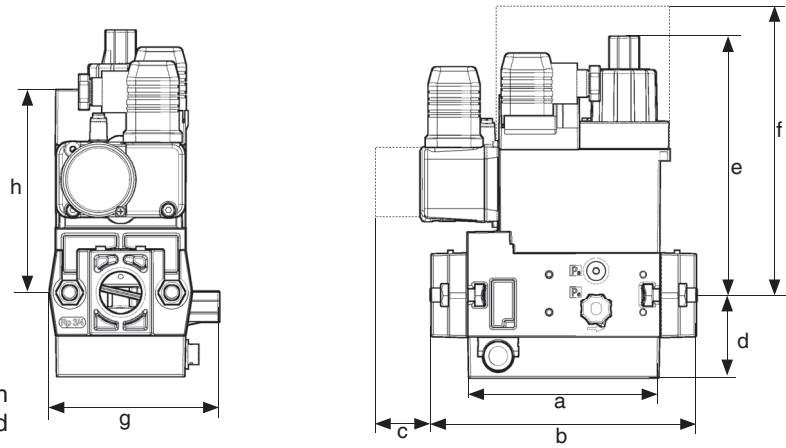

c = Space requirement for cover of pressure switch
f = Space requirement for exchanging the solenoid

Type	Nominal rating [VA] ~(AC) 230 V; +20°C		Dimensions [mm]								Weight [kg]
	S22	S52	a	b	c	d	e	f	g	h	
MB-D 407 B07	46	46	110	151	40	46	100	185	104	115	2,7
MB-DLE 407 B07	46	46	110	151	40	46	140	185	104	115	2,8
MB-D 410 B07/412 B07	110	110	140	185	40	55	125	245	120	135	5,3
MB-DLE 410 B07/412 B07	110	110	140	185	40	55	160	245	120	135	5,4

Electrical connection

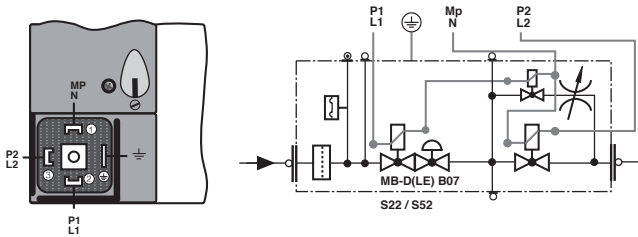

Pressure taps

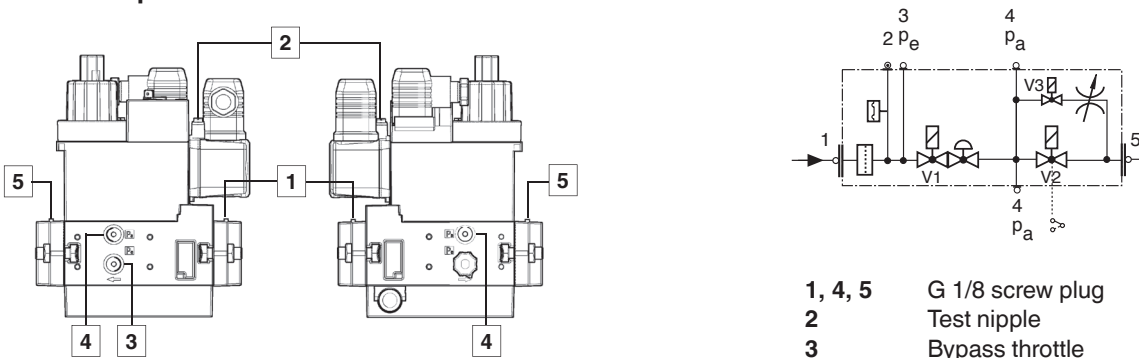

Volumetric flow pressure loss characteristic via bypass valve V3, restrictor open

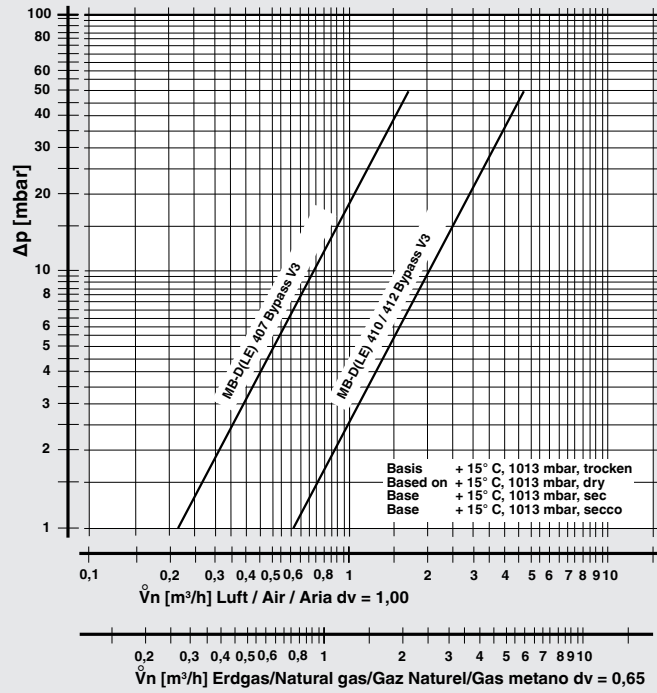

Volumetric flow pressure loss characteristics in regulated state with fine-mesh sieve

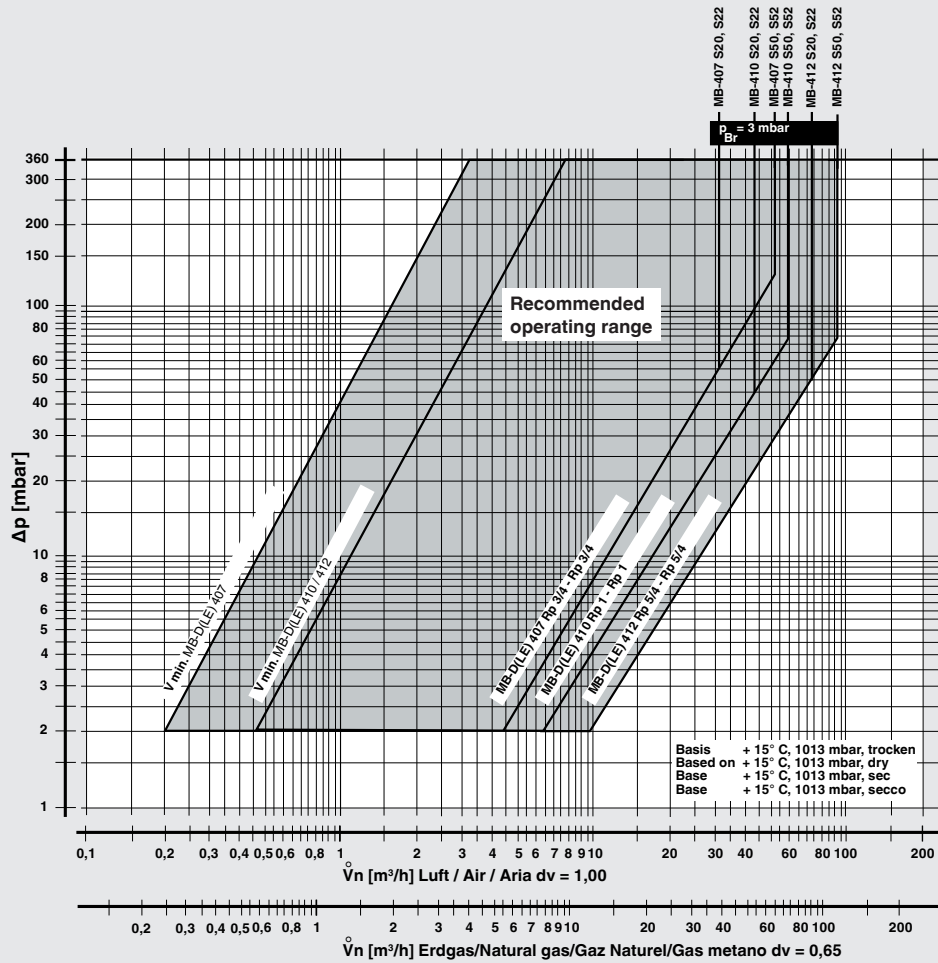

f =

Dichte Luft
Spec. weight air
poids spécifique de l'air
peso specifico aria

Dichte des verwendeten Gases
Spec. weight of gas used
poids spécifique du gaz utilisé
peso specifico del gas utilizzato

Gas type	Density [kg/m³]	dv	f
Nat. gas	0.81	0.65	1.24
City gas	0.58	0.47	1.46
LPG	2.08	1.67	0.77
Air	1.24	1.00	1.00

$$\dot{V}_{\text{verwendetes Gas/gas used/ gaz utilisé/gas utilizzato}} = \dot{V}_{\text{Luft/air/aria}} \times f$$