

Magnetic gear wheel encoder RGM2G-A with analog output signals



Contactless incremental encoder for measuring rotary motion

- High-resolution measurement of rotational speed and rotational angle up to 60,000 1/min
- Rotational direction recognition
- Robust, not sensitive to dirt
- Temperature stability up to 110°C

- High EMC and ESD stability (up to 30kV)

- Bespoke specifications due to a flexible design principle

- I2C interface for the fine-tuning of signal parameters if required
- Automatic stabilisation of signal amplitudes (option)

- Use in drive spindles of machine tools
Installation in drive motors

Output signals

- SIN- and COS signals with 1Vpp
- Reference signal
- Remote Sense RS_UB
- Supply voltage UB = 5V
- Reverse voltage protection
- Short-circuit proof

Principle of measurement

- Magnetic, contactless gauging of the steel gear wheels with module $M = 0.3$ or 0.5
- Use of magneto-resistive (GMR) sensor elements
- High degree of measurement accuracy when using e.g. type ZR3-256/Di or ZR5-256/Di measuring gear wheels

Design

- Robust metal sensor housing
- GMR-Sensor elements
- Frontal coverage of the sensor elements using metal foil to act as extra protection against ESD impulses
- Electronics for signal conditioning
- Complete sealing of sensor interior
- Screened connection cable with AWG28
- Optional connector plug

RGM2G-A-...3

... for gear wheel module $M = 0.3$

RGM2G-A-...5

... for gear wheel module $M = 0.5$

Magnetic gear wheel encoder RGM2G-A Specifications

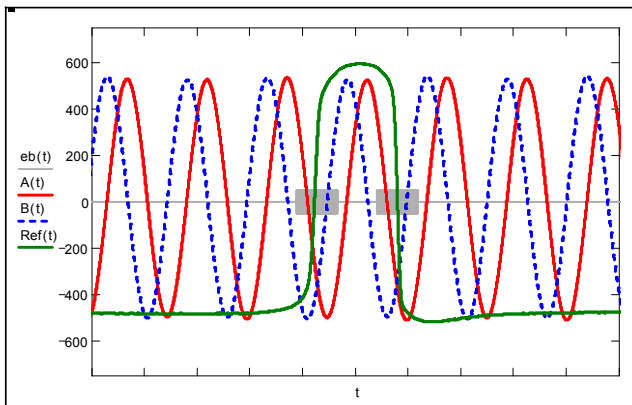

Typical signal aspect. The signal spurs A, B and ref. are depicted. The area highlighted in grey shows the optimal position of the 0 channels for the ref. signals (area of unambiguousness).

Signal parameters

Before delivery, each encoder is balanced at the nominal distance encoder - gear wheel $d_o = 0.1\text{mm}$ (for $M = 0.3$) and 0.3mm (for $M = 0.5$) on optimal signal values (amplitude 1Vpp , offset 0mV , phase 90° , unambiguousness of the reference pulse; signal aspect type - see figure).

The signal parameters may deviate from the optimal values due to subsequent tolerances of attached parts, gear wheel quality and the influence of temperature and rotational speed.

- | | |
|------------------------------|---|
| ■ Signal type | Analog, differential signals
SIN (spur A),
COS (spur B)
Ref. pulse
Inverted signals A, B & Ref. |
| ■ Signal amplitude A & B | $1\text{Vpp} \pm 20\% *$ |
| ■ Amplitude differential A/B | $0.9 \dots 1.1 *$ |
| ■ Phase A to B | $90^\circ \pm 1^\circ$ |
| ■ Offset - static | $\pm 20\text{mV}$ |
| ■ Freq. of measurement | $0 \dots 200\text{kHz}$ |

* Conditions: $U_B = 5\text{VDC}$; $f < 50\text{kHz}$; automatic stabilisation of signal amplitudes is inactive (see page 4).

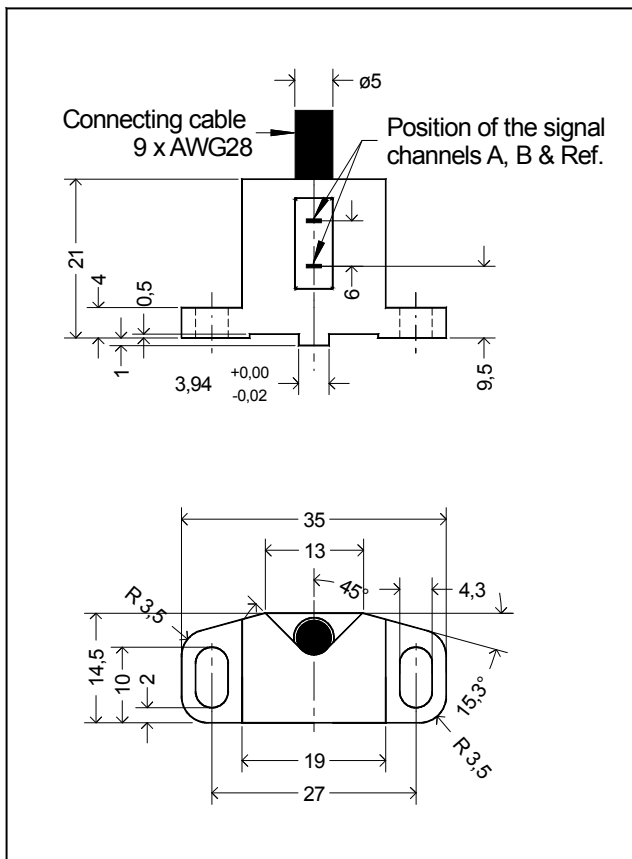

General parameters

- | | |
|--|--|
| ■ Supply voltage U_B | $5\text{VDC} \pm 5\%$ |
| ■ Wattage
Without load | 50mA |
| ■ Operating temperature | $-20 \dots 85^\circ\text{C}$
(up to 100°C on request) |
| ■ Storage temperature | $-30 \dots 110^\circ\text{C}$ |
| ■ Optimal distance d_o
encoder - gear wheel | $0.1 \pm 0.02\text{mm}$ for $M = 0.3$
$0.3 \pm 0.02\text{mm}$ for $M = 0.5$ |
| ■ Vibration resistance | bis 200m/s^2 |
| ■ Shock resistance | bis 2000m/s^2 |
| ■ Type of protection | IP68 |

Magnetic gear wheel encoder RGM2G-A

Assembly & Electrical connection

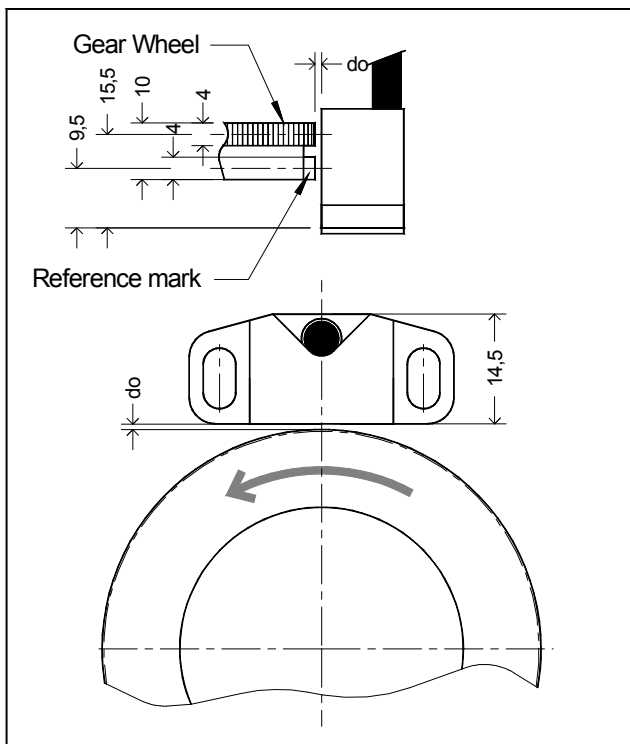

The arrow indicates the direction of movement during counter-clockwise rotation of the gear wheel with a view to the encoder- illustrated in the example of the RGM2G-A-M... encoder

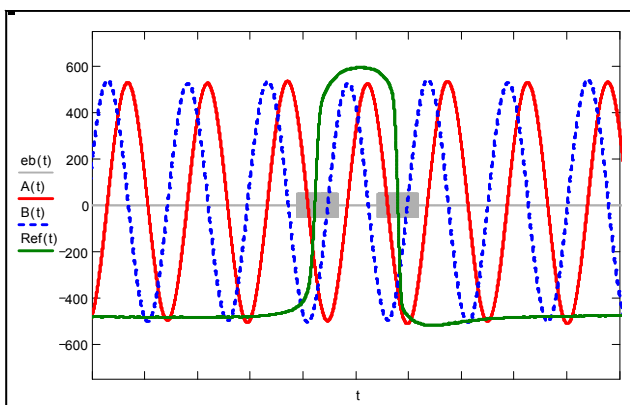

Typical signal aspect during counter-clockwise rotation of the gear wheel with a view to the encoder. The signal spurs A, B and ref. are depicted. The area highlighted in grey shows the optimal position of the 0 channels of the ref. signals (area of unambiguousness).

Assembly

The encoder is assembled using the following procedure:

1. Gauge blocks of the corresponding gauges do are located on the front side of the encoder.
2. Fix the encoder using 2 M4 screws. The screws are still not firmly tightened. The encoder should be loose.
3. Push the encoder slightly against the gear wheel. Completely tighten the screws alternately.
4. After screwing the encoder tightly, remove the gauge block (spacer) in the upward direction.

Distance encoder - gear wheel d (air gap)

The optimal distance encoder - gear wheel do is:

- 0.1 +/- 0.02mm for Modul $M = 0.3$
- 0.3 +/- 0.02mm for Modul $M = 0.5$

For this distance do the encoders are balanced on optimal signal parameters. If required, the signal parameters can be adjusted via the I2C signal interface (see page 4).

Cable assignment (Type P)

On the output of the encoder is a screened cable with 9 wires AWG28. The cable is assigned as follows:

- Signal A + brown
- Signal A - green
- Signal B + grey
- Signal B - orange
- Signal Ref + red
- Signal Ref - black
- UB = 5VDC violet
- GND (0V) yellow
- RS_5V blue

The shield is connected to the casing on the encoder side.

Magnetic gear wheel encoder RGM2G-A I2C Interface

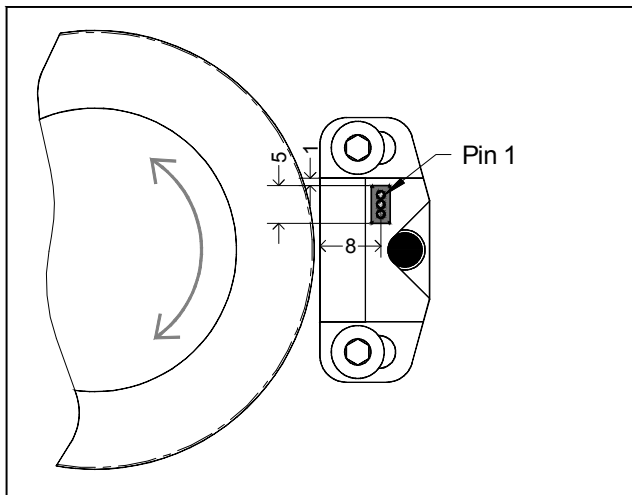

Position and configuration of the connection sockets for the I2C interface on the back of the encoder.
The connection sockets can be reached after partially removing the guard tag.

I2C-Interface

If required, the I2C interface can facilitate the fine-tuning of the parameters amplitude, offset and phase of the encoder signals A, B & Ref.

Before dispatch, the utmost care is taken to ensure that all RGM2G encoder signals are working optimally. In spite of this, a single fine-adjustment of the signal parameters might be required. There are two possibilities for that:

1. By "sensitively" adjusting the position of the encoder to the gear wheel you can set the best possible signal parameters. This method requires a lot of time and experience when installing the encoder.
2. After installing the RGM2G encoder at the required distance do from the gear wheel, the required fine-adjustment of the encoder signals is quickly made via the I2C-interface.

Automatic amplitude stabilisation (option)

The signal electronics of the encoder enables the amplitude of signals A & B to be stabilised to a value of 1 Vpp. This helps to offset any problems the axis or gear-wheel has when rotating.

Stabilisation of the amplitude can be configured via the I2C-interface.

Fine-tuning via the I2C-interface

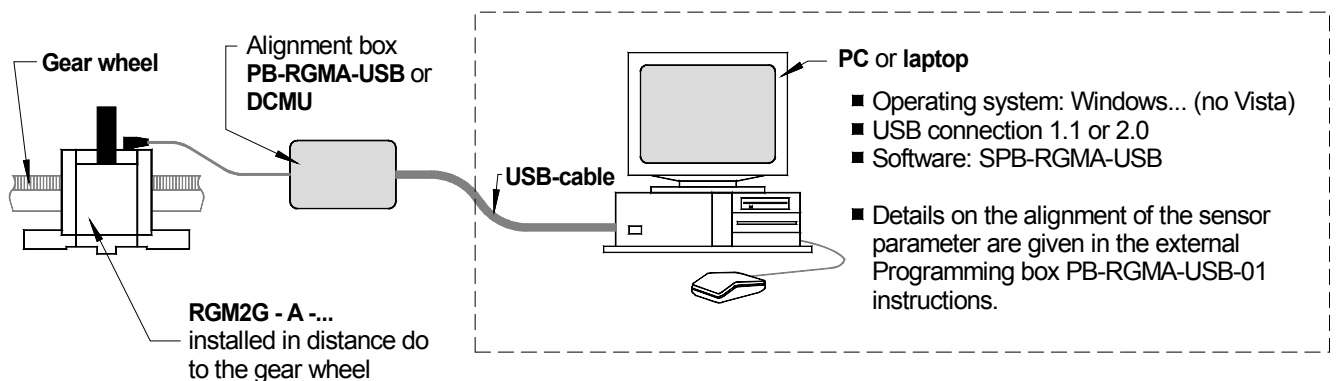

Magnetic gear wheel encoder RGM2G-A

Order identifiers - Standard version

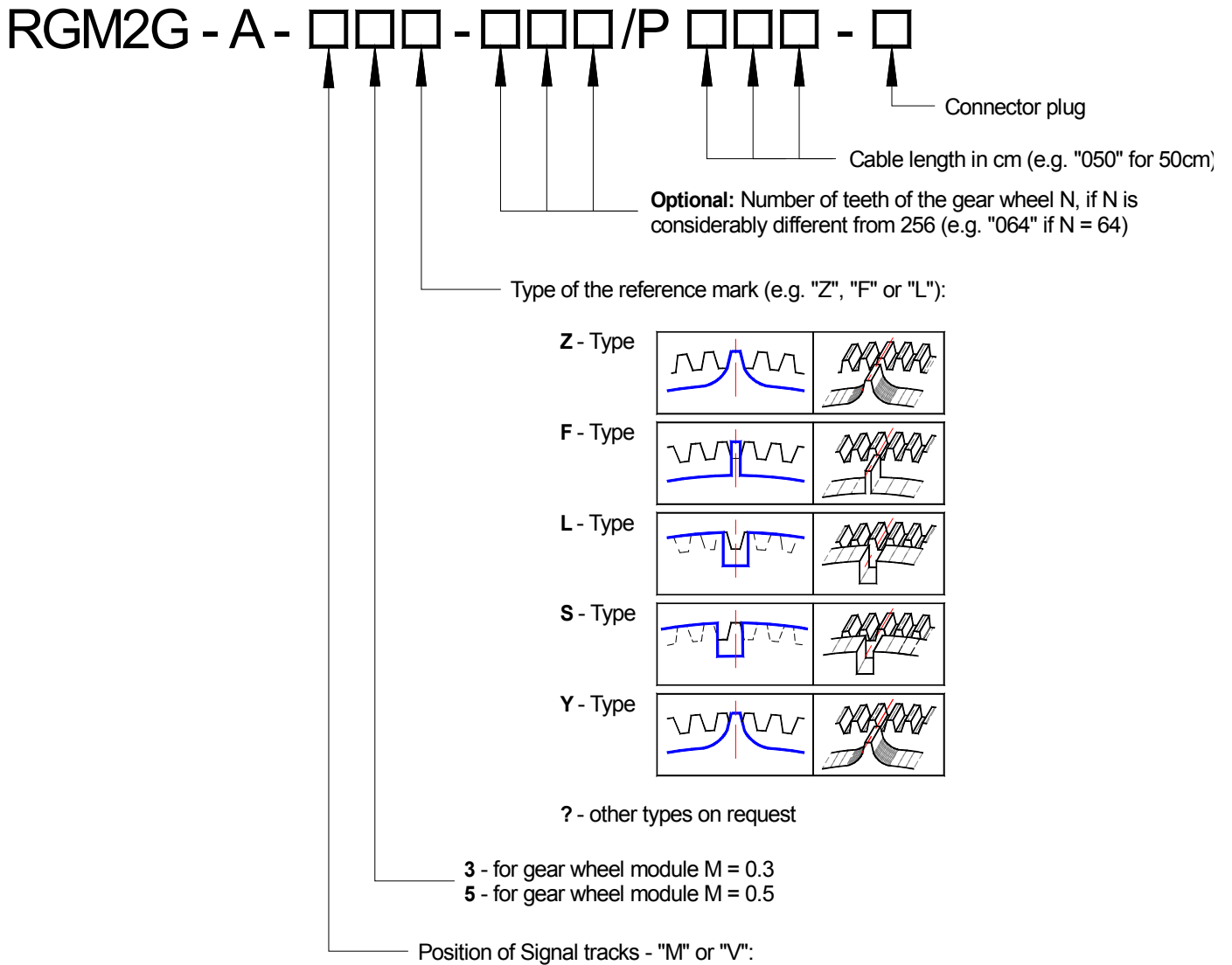

Accessories

Measuring gear wheels: **ZR3-256/Di** or **ZR5-256/Di**
Other types of gear wheels on request.

External interpolation box for the digitalisation and interpolation of the analogue encoder signals

PB-RGMA-USB box with **SPB-RGMA-USB** software for the fine alignment of encoder signals via the I2C-interface

Digital calibration and measurement unit **DCMU** for the visualisation, detailed analysis and fine alignment of the encoder signals.

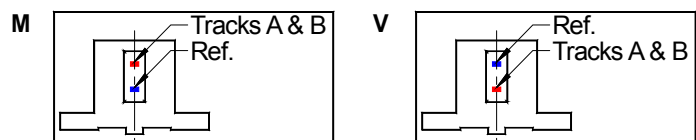

Magnetic gear wheel encoder RGM2G-A

Order identifiers - Cable assignment

RGM2G - A - □□□ - □□□ / **P** □□□ - □

Cable assignment

On the output of the encoder is a screened cable with 9 wires AWG28. The cable is assigned as follows:

■ Signal A +	brown
■ Signal A -	green
■ Signal B +	grey
■ Signal B -	orange
■ Signal Ref +	red
■ Signal Ref -	black
■ UB = 5VDC	violet
■ GND (0V)	yellow
■ RS_5V	blue

The **shield** is connected to the casing on the encoder side.

RGM2G - A - □□□ - □□□ / **T** □□□ - □

Cable assignment

A shielded cable with 9 wires, AWG28, is attached at the sensor output. The outer sheath is green according to RAL6018, based on DESINA specifications.

The cable is assigned as follows:

■ Signal A +	white
■ Signal A -	brown
■ Signal B +	pink
■ Signal B -	black
■ Signal Ref +	grey
■ Signal Ref -	yellow
■ UB = 5VDC	red
■ GND (0V)	blue
■ RS_5V	green

The **shield** is connected to the casing on the encoder side.

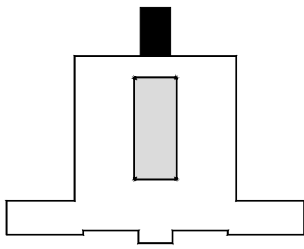

Magnetic gear wheel encoder RGM2 series

Order identifiers - overview

Analogue output signals SIN, COS & Ref.

RGM2G - A - □□□ - □□□/P □□□ - □

... Standard version

RGM2G - A - □□□ - □□□/T □□□ - □

... Standard version
... With modified cable configuration

RGM2T - A - □□□ - □□□/T □□□ - □

... Increased working temperature up to 120°C
... With modified cable configuration

RGM2S - A - □□□ - □□□/T □□□ - □

... With mounting base
... Compatible with SIZAG sensor (SIEMENS)
... With modified cable configuration

RGM2G - A - □□□ - □□□/T □□□ - **DM**

... With 17-pin flange socket on mounting base
... With modified cable configuration

RGM2G - **AS** - □□□ - □□□/P □□□ - □

RGM2S - **AS** - □□□ - □□□/T □□□ - □

RGM2T - **AS** - □□□ - □□□/T □□□ - □

RGM2S - **AS** - □□□ - □□□/T □□□ - □

RGM2G - **AS** - □□□ - □□□/T □□□ - **DM**

... With activated amplitude stabilisation

Digital output signals according to RS432 (TTL)

RGM2G - **D**□ - □□□ - □□□/P□□□ - □

... Standard version
... With integrated interpolation electronics

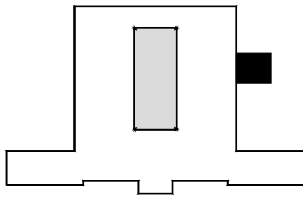

Magnetic gear wheel encoder RGM2 series Order identifiers - overview

Analog output signals SIN, COS & Ref.

RGM2G - A - □□□ - □□□/SP □□□ - □

... Standard version

RGM2G - A - □□□ - □□□/ST □□□ - □

... Standard version
... With modified cable configuration

RGM2T - A - □□□ - □□□/ST □□□ - □

... Increased working temperature up to 120°C
... With modified cable configuration

RGM2S - A - □□□ - □□□/ST □□□ - □

... With mounting base
... Compatible with SIZAG sensor (SIEMENS)
... With modified cable configuration

RGM2G - A - □□□ - □□□/ST □□□ - DM

... With 17-pin flange socket on mounting base
... With modified cable configuration

RGM2G - AS - □□□ - □□□/SP □□□ - □

RGM2S - AS - □□□ - □□□/ST □□□ - □

RGM2T - AS - □□□ - □□□/ST □□□ - □

RGM2S - AS - □□□ - □□□/ST □□□ - □

RGM2G - AS - □□□ - □□□/ST □□□ - DM

... With activated amplitude stabilisation

Digital output signals according to RS432 (TTL)

RGM2G - D□ - □□□ - □□□/SP□□□ - □

... Standard version
... With integrated interpolation electronics

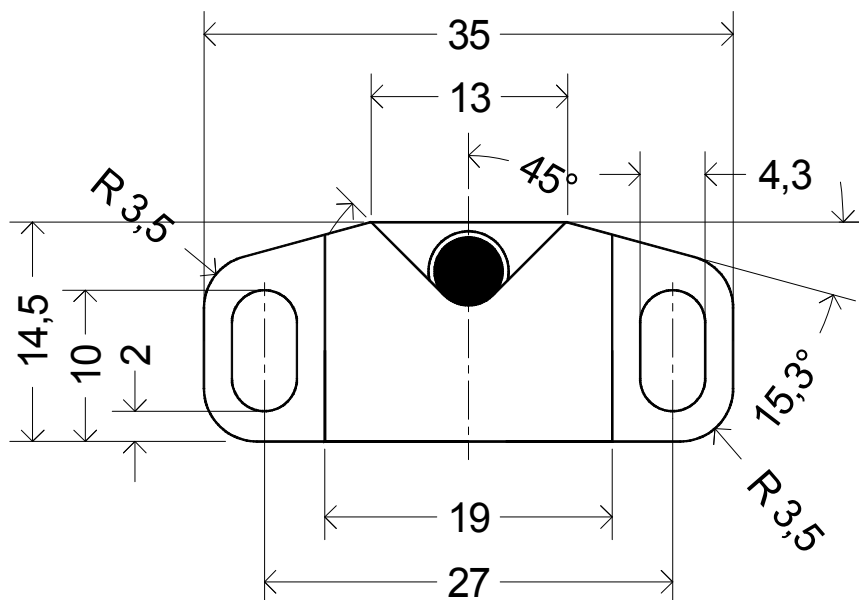
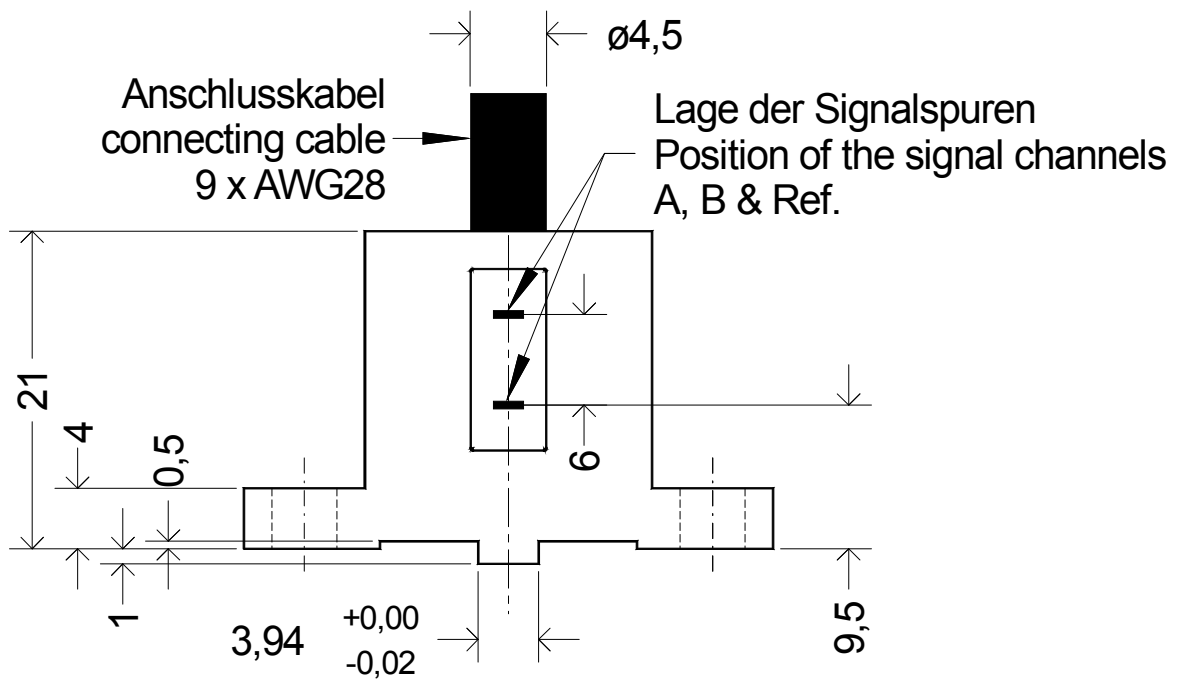

Material	Allgemeintoleranzen	Dateiname RGM_ax	Datum 27.10.09	Maßstab 2:1
VS Sensorik GmbH		RGM2G-A ... /...		
		09VS042701	Version 1	Blatt 1

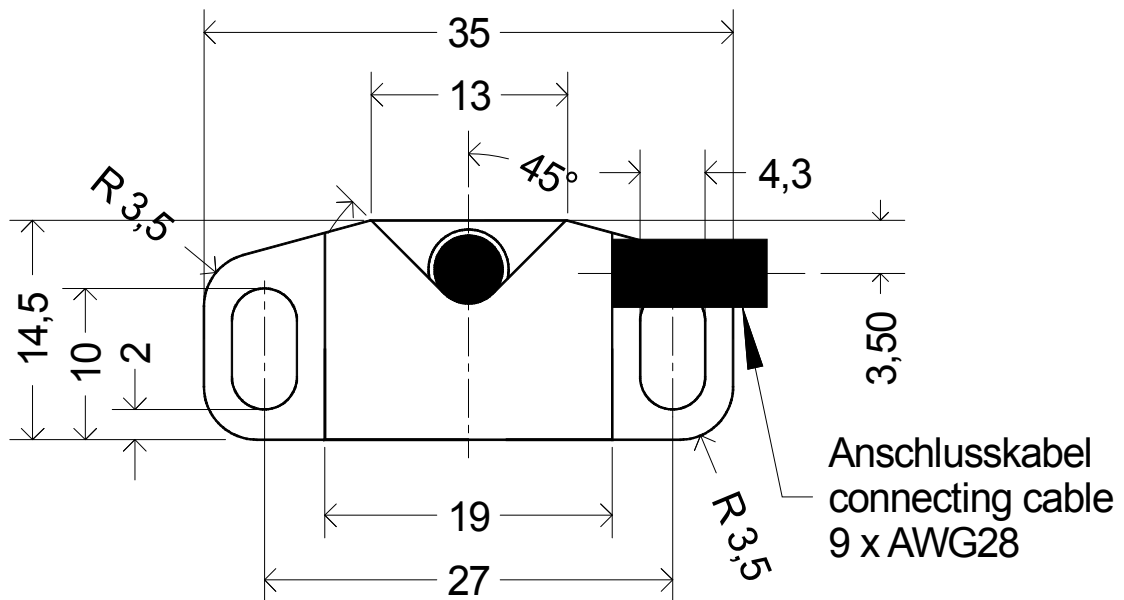
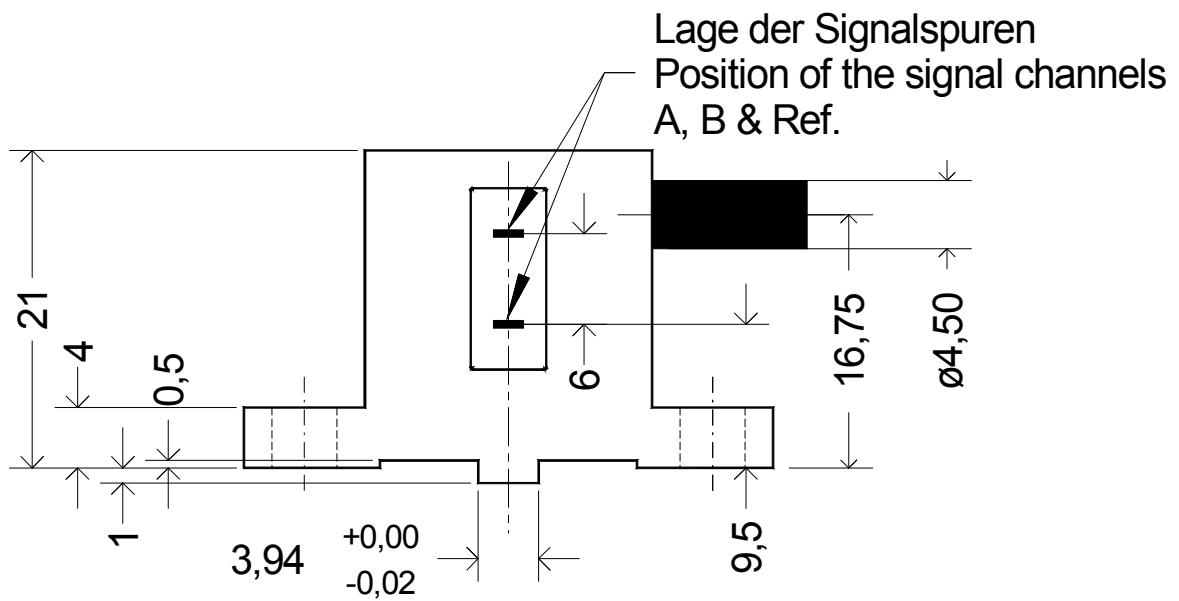

Material	Allgemeintoleranzen	Dateiname RGM_tan	Datum 27.09.2009	Maßstab 2:1
VS Sensorik GmbH		RGM2G.../S...		
		09VS091709	Version 1	Blatt 1