

## BC1000

## Burner Controller

### USER'S MANUAL



### Overview

BC1000 is the flame switch for application in large commercial and industrial burner installations. Its functions can be,

1. Simple flame switch which indicates the presence or absence of a flame or,
2. Flame safeguard primary controls capable of providing system "Safe-start check" and flame sensing functions.

Built-in safe-start check circuit checks flame detector at start (when Terminal 1 energized). If a flame or flame simulating condition exists, it doesn't switch safety relay, so system may not start sequence when it is applied to primary control. In case of flame switch application, it also provides a level of safety by checking flame detector status with this function. BC1000 needs flame rod or Honeywell mini-peeper UV flame detector for flame sensing up to models.

### Features

- 1) It is designed as compact-size and adopts plug-in mounting onto subbase for surface mounting.
- 2) Mounting can be panel mounted or onto DIN RAIL which makes installation easier if multiple devices are placed in a panel.
- 3) It may interrupt ignition if abnormal flame condition exists by safe-start check at start-up.
- 4) 3 Light Emitting Diodes(LED) provided for monitoring the operation status : Power, Flame, Safe-Start Check(SSC)
- 5) Flame strength can be measured or continuously monitored with front terminal.

### Table of Contents

1. Overview .....	1
2. Features .....	1
3. Specifications .....	2
4. Wiring and Installation .....	2
5. Operations and Sequence .....	5
6. Safety Cautions .....	6

# Specifications

## A. Models

Model	Rated voltage	Power consumption	Flame response time	Flame sensor
BC1000A0110F	AC110V 50/60Hz	5W	2 ± 1 sec.	Rectification FLAME ROD
BC1000A0110U	AC110V 50/60Hz	8W	2 ± 1 sec.	C7035A,C7027A
BC1000A0220F	AC220V~230V 50/60Hz	5W	2 ± 1 sec.	Rectification FLAME ROD
BC1000A0220U	AC220V~230V 50/60Hz	8W	2 ± 1 sec.	C7035A,C7027A

## B. Electrical and Environmental Ratings

Item	Specification
Rated voltage	AC110V 50/60Hz, AC220V~230V, 50/60Hz
Allowable voltage	-15% ~ +10% of the rated voltage
Allowable Ambient temperature	Stand-alone mounting: -20~+60℃ Gang mounting (2 or more sets): -20~+45℃
Allowable ambient humidity	90% RH and lower (condensation not allowed)
Vibration resistance	0.5G 10 to 150Hz for 1h each in x,y and z directions
Insulation resistance	Above 50MΩ at DC500V between terminals and Ground
Dielectric strength	Leakage current should be 10mA and lower for 1s at AC1800V or for 1 min at AC1500V between terminals and ground terminal (except for the terminal of flame detector)
Lightening surge	10KV, voltage waveform: 1.2uS at increase, 50uS at decrease when surge absorber is applied between terminal 8 and Ground. Recommended surge absorber: G-105336(Honeywell Korea)
Design Life	250,000 operations(under ambient temperature and humidity, rated voltage, and rated load)
Terminal ratings	③ - ② : 250VA ③ - ④ : 250VA
Flame strength	Flame On : 1V or less Flame Off : 0.2V or more
Size	42.5(W) x 90.0(H) X 95.5(D)mm (include sub-base)
Weight	Approx. 334g (include sub-base)

# Wiring and Installation

## A. Cautions

- It should not be installed at the following places.
  - Place vulnerable to special chemicals or corrosive gas (ammonia, sulfur, chlorine, ethylene compound, acid and others)
  - Place with water or excessive humid.
  - Place subject to high temperature or vibration for a long while.
- Disconnect the power supply from the main disconnect before beginning installation to prevent electrical shock and equipment damage. Supply power to BC1000 after finishing all wiring and completing proper checks.
- Do not exceed load on its terminal rating

- Power cable, ignition transformer's HIGH-VOLTAGE cable and flame detector's cable must not run together. Wires of UV flame detector must be run in their own conduit independent of other power carrying lead-wires. Especially HIGH-VOLTAGE cable of the ignition transformer must be physically separated and be away from BC1000 at least, 10cm
- Ground has to be facilitated in accordance with applicable code, ordinances and standard. And the burner(body frame) should be grounded(if installed on a boiler, it should be on the boiler drum)
- Ignition transformer's HIGH-VOLTAGE cable should be firmly connected to avoid contact failure. And Ignition transformer should be directly installed on the burner or metal parts electrically connected to the burner.

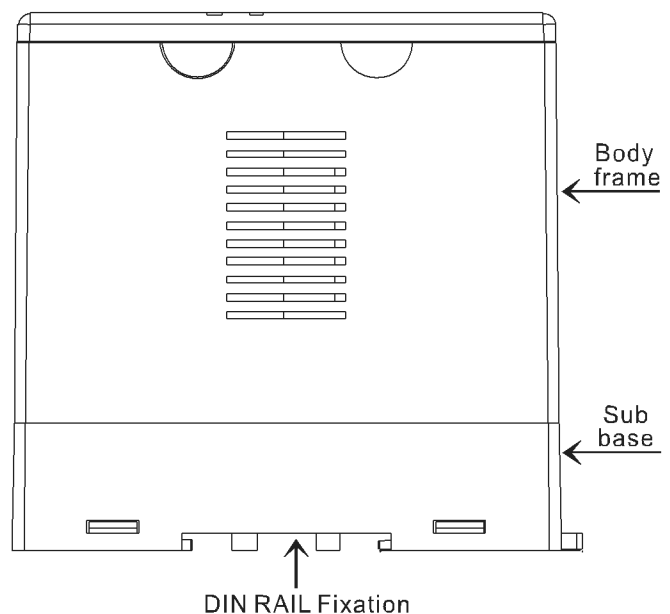
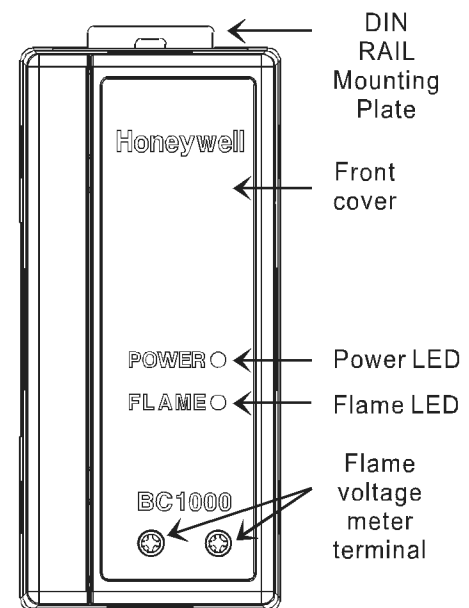

[Figure 1] Appearance

### B. Separation and Installation of Body frame and Sub-Base

- 1) Remove the front cover seen in figure 1 and unfasten the fixation screw about 8 turns CCW.
- 2) Hold the body frame and sub-base with both hands and pull out body frame from subbase. At the moment, note that applying excessive force may cause damage.
- 3) Position sub-base and mount by fastening appropriate screws.
  - \* If mounting the subbase onto DIN RAIL, refer Figure 4.

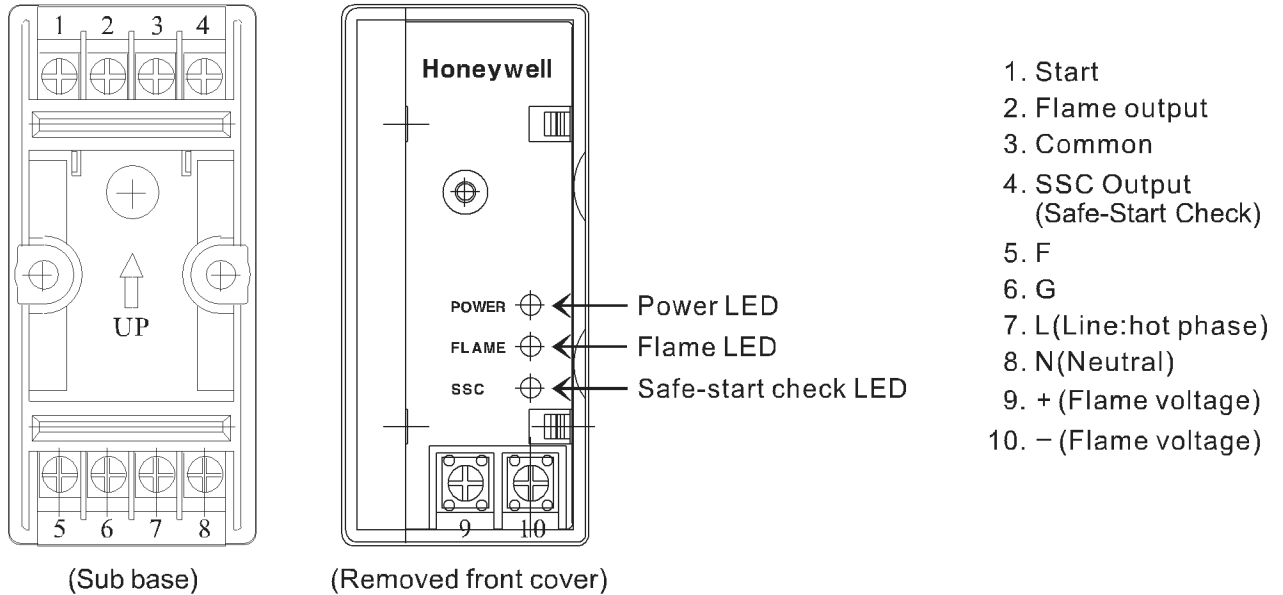

[Figure 2] Subbase terminals and front terminals

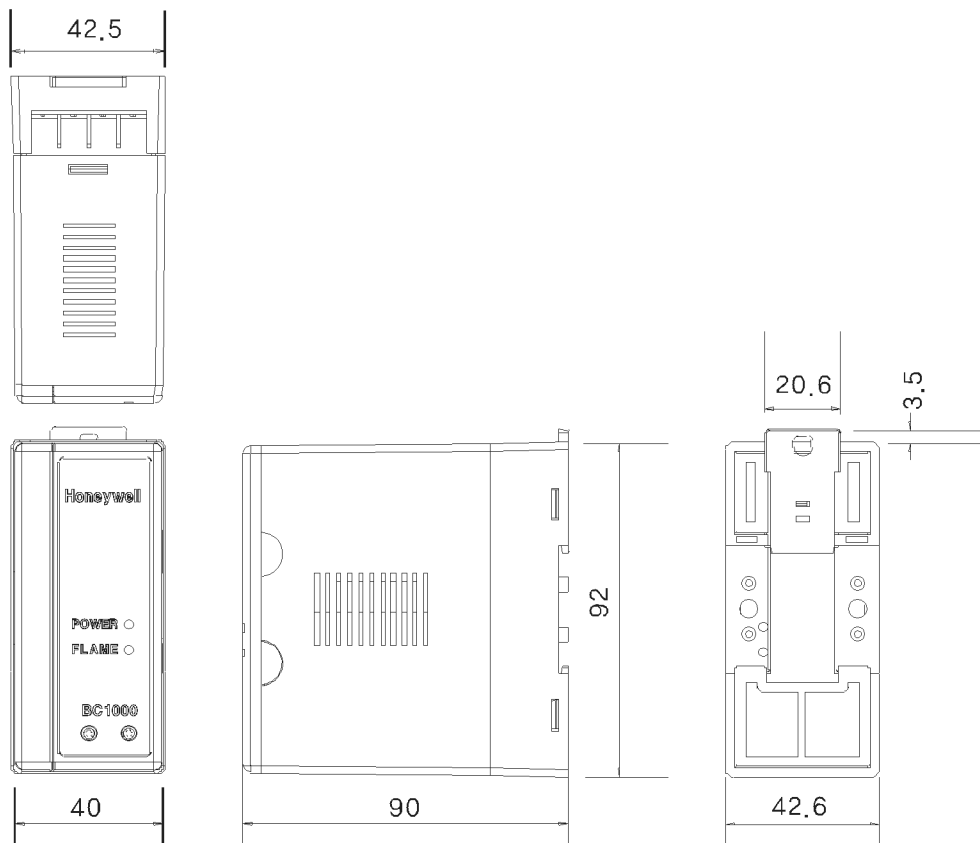

[Figure 3] Dimensions

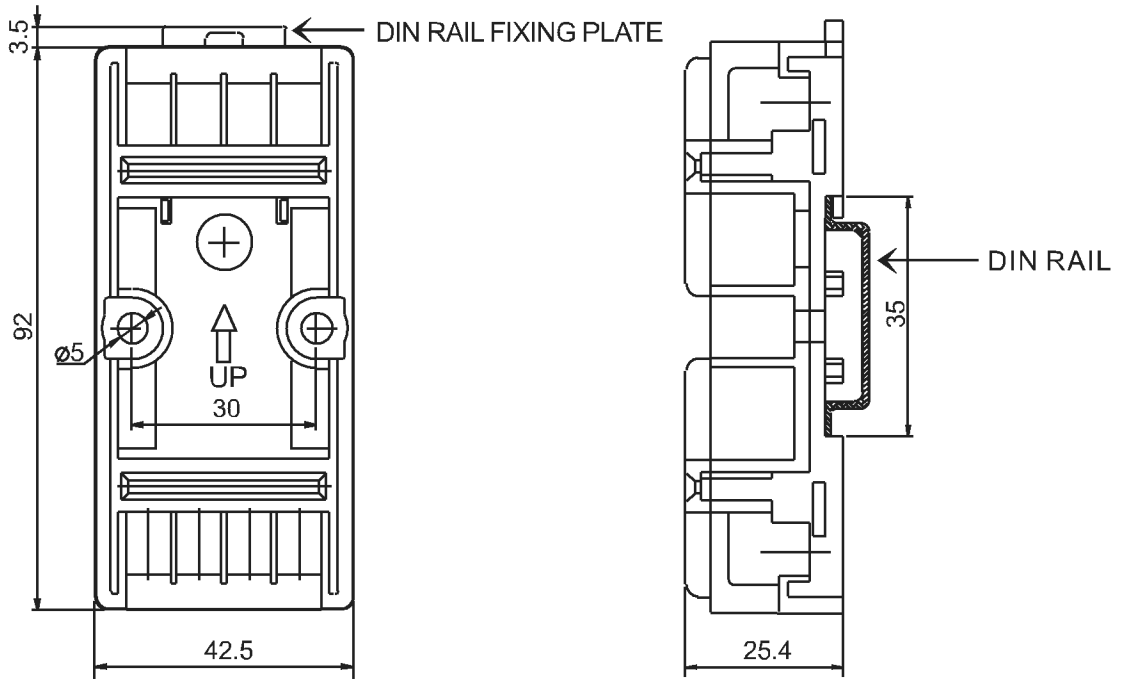

[Figure 4] Dimensions (Din Rail Fixed)

**C. Wiring Subbase**

1) Figure 2 is example of typical wiring diagrams. Refer Figure 5 for terminal location.

① Manual Ignition (Intermittent pilot)

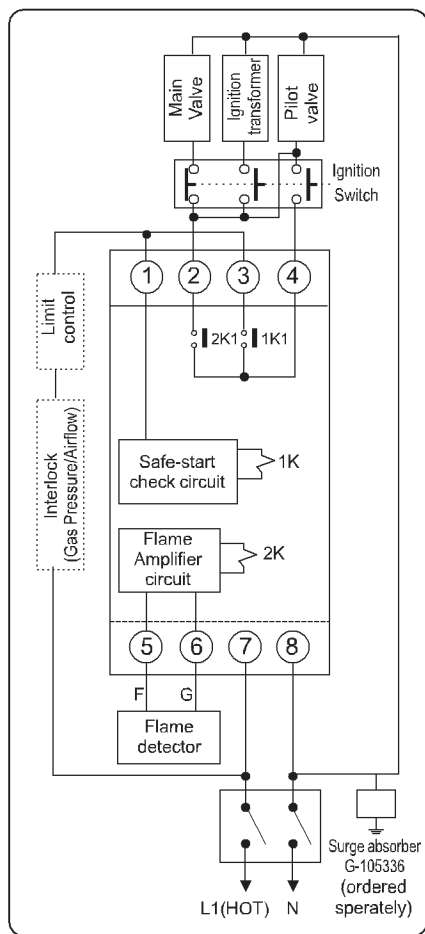

② Flame Monitoring

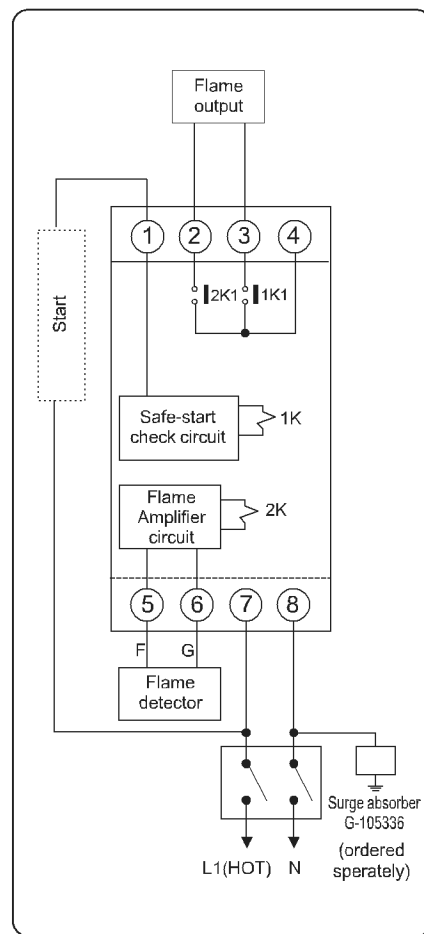

[Figure 5] Example of wiring to external devices

2) Internal relay operation

- ① Safe-start check circuit
  - : Verifies that a flame or flame simulating condition does exist once terminal 1 is energized
  - No flame : Safe relay closed (1K1 Close)
  - Flame : Keep safe relay opened (1K1 Open)
- ② Flame amplifier circuit
  - : Switching depending on flame or flame simulating condition exist
  - No flame : Flame relay opened (2K1 Open)
  - Flame : Flame relay closed (2K1 Close)

**D. How to install the flame detector**

To determine whether the installation location of flame detector correctly, measure the flame voltage. Measure the flame voltage by connecting (+) and (-) terminals to connect the terminal 9 and terminal 10 on the front terminal, respectively. The recommended flame detector voltage is over 2Vdc. And, the flame detection voltage is

limited to 5.5V max. With the flame detector installed and burners running, adjust the position of the flame detector for optimum.

For installing Honeywell mini-peeper UV flame detector, refer instruction manual of C7027/C7035/C7044.

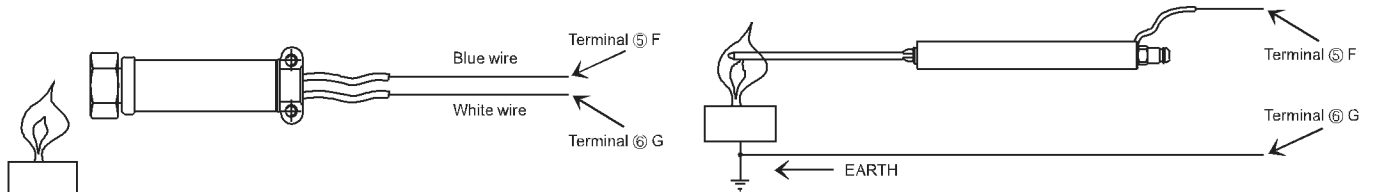

UV sensor cable: NEC Class 1 leadwires  
 Recommend Cable: 18 AWG copper conductor,  
 600 volt insulation, moisture-resistant wire

[Figure 6] Flame detector wiring

**Operations and Sequence**

1) Manual ignition system with Intermittent Pilot (Figure 5-①)

LED DISPLAY		STANDBY	SAFE-START	PFEP④	RUN	STANDBY
POWER		● POWER	● POWER	● POWER	● POWER	● POWER
FLAME		○	○	● FLAME	● FLAME	○
SSC		○	● SSC	● SSC	● SSC	○
Ignition switch				Ignition switch		
Pilot				Intermittent pilot③		
Main Valve					Main valve ②③	
limit/interlock				limit/interlock closed		
Flame signal			Safe-start check①	Flame proving		

- ① If flame is detected before safe-start check is complete, it holds operation. It resumes the run if flame signal stops
- ② Output if flame is detected and Ignition switch released
- ③ Stop operation if flame is lost during run(De-energize shut-off valve)
- ④ Pilot flame establishing period(PFEP): it should comply standard or codes.

2) Flame Monitoring System(normal operation)

LED DISPLAY		STANDBY	SAFE-START	FLAME MONITORING				STANDBY
	POWER	● POWER	● POWER	● POWER	● POWER	● POWER	● POWER	● POWER
	FLAME	○	○	○	● FLAME	○	● FLAME	○
	SSC	○	● SSC	● SSC	● SSC	● SSC	● SSC	○
Flame on					②		②	
Start			Start input (Safe-start check operation)					
Flame signal			Safe-start check <sup>1</sup>	No flame	Flame	No flame	Flame	

① If flame is detected before safe start check is complete, it holds operation. It resumes the run if flame signal stops.

② If flame is detected, flame relay switches.

## Safety Cautions



### WARNING

Fire or Explosion Hazard.  
Can cause severe injury , death or property damage.



### CAUTION

Electrical Shock Hazard or Equipment Damage Hazard.  
Can cause personal injury, or damage equipment.

**Read these instruction carefully when installing this products. The following precautions relating safety should be always followed. Failure to follow them could damage the product or cause a hazardous condition.**



### Warning

- 1) Disconnect the power supply from the main disconnect before beginning installation to prevent electrical shock and equipment damage. More than one disconnect may be required. Otherwise, a installer may be injured by electrical shock.
- 2) Do not touch any terminal of BC1000. It may cause electrical shock.
- 3) BC1000 verifies that a flame or flame simulating condition does exist at start-up. BC1000 should be used on burners that cycle on/off periodically or, in the absence of cycling, are periodically checked for proper operation (once or more in 24 hours of operation). For continuous operation more than 24 hours, it is recommended to apply Honeywell burner control system with self-checking function.
- 4) BC1000 does not have pre-purge function, which is required for burner ignition. Therefore, make sure to design a system fully in accordance with any code or standards by applying timer if it needed.
- 5) All wiring must comply with all applicable electrical codes, ordinances and regulations. And wire correctly as this instruction guides. When wiring fuel valve, do not wire it to L(Line:Hot phase). It may cause the leakage of fuel as the fuel valve opens irrespective of BC1000 because, if any, electric leakage may energizes the fuel valve. Make sure to wire it to N(Neutral: neutral conductor) side of power.
- 6) Follow the safety time for pilot flame establishing and main flame establishing in accordance with any standards and codes for device, facility or plant to apply it. In the

case(excessive ignition time), it may cause unexpected explosion due to remaining fuel or explosive gas mixture in a combustion chamber.

- 7) The flame failure response time of the device is 2 seconds( $\pm 1$ sec.). It should comply with standards and codes for device, facility or plant to install BC1000

and operate the device (It should comply the safety time according to EN746-2 in case of European Standard).

- 8) After turning off BC1000, there may be residual charge in terminal 5, a terminal "F" of the flame detector. Therefore, do not touch "F" terminal after the power-off. It may cause electrical shock.

## **Caution**

- 1) Installation, wiring, repair, maintenance, adjustment and other special works should be executed by competent experts who must be trained, experienced flame safeguard service technician.
- 2) Donot install BC1000 on the places with the following conditions.
  - A. Place vulnerable to special chemicals or corrosive gas (ammonia, sulfur, chlorine, ethylene compound, acid and others)
  - B. Place where the relative humidity ever reaches the saturation point. BC1000 is designed to operate in maximum 90% relative humidity continuous, non-condensing, moisture environment.
  - C. Place subject to hot temperature or vibration for a long while.
- 3) Apply reliable high quality timer, auxiliary relay and other devices for supplementary functions, and wire correctly.
- 4) Follow instruction manual for Installation and wiring.
- 5) Be sure loads do not exceed the terminal ratings.
- 6) UV flame detector should be installed properly, so the detector must not exposed to other source of ultraviolet radiation and Gamma ray and X-ray source, the most common being ignition spark. Other source could actuate the detection system, so it may result in explosion.
- 7) When wiring C7027/C7035/C7044 UV flame detector, white wire should be connected to G Terminal (Terminal 6) while blue wire should be connected to F terminal (Terminal 5 ). Incorrect wiring may cause flame detector damage.
- 8) High-voltage cable of an ignition transformer should be physically separated and be away from BC1000 about, at least, 10cm
- 9) Ground cable of an ignition transformer should be electrically connected to any metallic part of the burner (body frame).
- 10) F and G wires of UV flame detector must be run in their own conduit independent of other power carrying lead-wires. Especially HIGH-VOLTAGE cable of the ignition transformer must not run together.
- 11) Supply the rated voltage and frequency suitable for a model of BC1000.
- 12) Do not connect the power supply until all wiring and installation is complete. Incorrect wiring may cause the damage on terminals or electrical shock.
- 13) Ground must follow all applicable code, ordinances and standard.
- 14) After wiring, it is necessary to check whether cables are correctly wired. Any incorrect wiring may cause destruction, malfunction or electrical shock.
- 15) Check whether the flame detector detects ignition spark. If it detects, you must adjust or change the installation location so that the flame detector do not output Flame On by detecting ignition spark.
- 16) Considering that BC1000 is used to execute important functions for your safe operation, operate and use BC1000 correctly according to this operating manual.
- 17) In case of restart after the safety interruption, please check the device.
- 18) Check the flame voltage once a month, at least. Any unexpected interruption of the device resulting from insufficient flame voltage may be prevented in advance.
- 19) BC1000 is subject to the lifetime. If the lifetime of a device on which BC1000 is installed is longer than that of BC1000, regularly check it to replace BC1000 timely.
- 20) When replacing BC1000, check the device according to the procedure prior to use.
- 21) Periodically check the device according to the operating manual.
- 22) When cleaning the burner, make sure to clean up the flame detector as well.
- 23) Do not move the device as being connected to DIN rail. If being dropped, the device may be destructed.