

26230, 80107 NAMUR & INLINE, 3/2 & 5/2

indirectly electromagnetically actuated piston spool valves

- Port: G 1/4, NAMUR interface
- For single and double-acting actuators
- Manual override with detent standard
- Proven design of the piston valve soft seal system
- Variable valve/solenoid combination
- Service-friendly and maintenance-free



Technical features

Medium:
Filtered, lubricated or non-lubricated
Air
Compressed air

Actuation
3/2, 5/2 and 5/3-way piston slide valves indirectly operated electromagnetically

Operating pressure:
2 ... 8 bar (29 ... 116 psi)
1 ... 10 bar (14,5 ... 145 psi)

Orifice:
6 mm (G1/4), 12 mm (G1/2)

Port size:
G1/4 NAMUR, G1/4, G1/2

Installation position:
Any, preferably magnet vertical

Flow direction:
Fixed

Fluid/Ambient temperature:
–10 ... +50°C (14 ... 122°F)
(see solenoid table)
Air supply must be dry enough to avoid ice formation at temperatures below +2°C (35°F).

Materials:
Housing: Aluminium
Pilot flange: plastic
Seal: NBR

Additional models:
Upon request

Flow conversion:
Cv US gallon/min (water) =
l/min (air) x 0.001
Kv m³/h (water) =
l/min (air) x 0.000906

Technical data 3/2 way valve

Symbol	Port size	Actuation/return	Operating pressure (bar)	Flow (l/min)	Weight (kg)	Dimensions No.	Solenoid group	Model *1)
	G1/4	Solenoid/air spring	1 ... 10	1325	0,4	1	B	8010750 *2)
	G1/4	Solenoid/air spring	2 ... 8	1325	0,4	1	A	8010751 *2)
	G1/2	Solenoid/air spring	1,5 ... 10	3300	0,7	2	B	8010850 *2)
	G1/2	Solenoid/air spring	2 ... 8	3300	0,7	2	A	8010851 *2)
	G1/4	Solenoid/air spring	1 ... 10	1325	0,4	1	B	8012750 *2)
	G1/2	Solenoid/air spring	1,5 ... 10	3300	0,7	2	B	8012850 *2)
	G1/4	Solenoid/Solenoid	1 ... 10	1325	0,77	3	B	8011750
	G 1/4 NAMUR	Solenoid/air spring	2 ... 8	1325	0,4	4	A	8010777 *2)

*1) When ordering please indicate solenoid, voltage and current type (frequency).

*2) Port 3 cannot be throttled

5/2-way

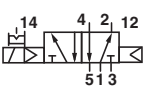
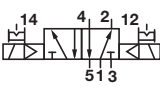
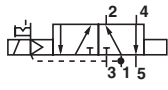
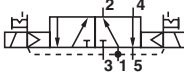
Symbol	Port size	Actuation/return	Operating pressure (bar)	Flow (l/min)	Weight (kg)	Dimensions No.	Solenoid group	Model *1)
	G1/4	Solenoid/air spring	1 ... 10	1325	0,4	5	B	2623000 *2)
	G1/4	Solenoid/air spring	2 ... 8	1325	0,4	5	A	2623001 *2)
	G1/2	Solenoid/air spring	2 ... 10	3300	0,7	6	B	2623500 *2)
	G1/2	Solenoid/air spring	2 ... 8	3300	0,7	6	A	2623501 *2)
	G1/4	Solenoid/Solenoid	1 ... 10	1325	0,4	7	B	2623100
	G1/4	Solenoid/Solenoid	2 ... 8	1325	0,4	7	A	2623101
	G1/2	Solenoid/Solenoid	2 ... 10	3300	0,7	8	B	2623600
	G1/2	Solenoid/Solenoid	2 ... 8	3300	0,7	8	A	2623601
	G 1/4 NAMUR	Solenoid/air spring	2 ... 8	1325	0,55	9	A	2623077 *2)
	G 1/4 NAMUR	Solenoid/Solenoid	2 ... 8	1325	0,9	10	A	2623177

*1) When ordering please indicate solenoid, voltage and current type (frequency). *2) Port 5 cannot be throttled

3/2 or 5/2 way function (conversion instructions see page 9)

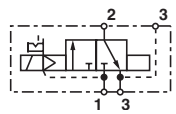
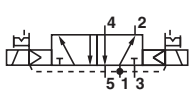
Symbol	Port size	Function	Actuation/return	Operating pressure(bar)	Flow (l/min)	Weight (kg)	Dimensions No.	Solenoids group	Model *1)
	G 1/4 NAMUR	3/2 & 5/2	Solenoid/Solenoid	2 ... 8	1325	0,4	11	A	2623079 *2)
	G 1/4 NAMUR	3/2 & 5/2	Solenoid/Solenoid	2 ... 8	1325	0,9	12	A	2623179

*1) When ordering please indicate solenoid, voltage and current type (frequency). *2) Port 3 cannot be throttled

5/3 position directional control valve

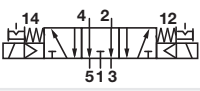
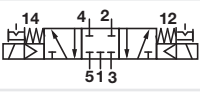
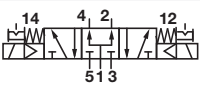
Symbol	Port size	Function	Actuation/return	Operating pressure(bar)	Flow (l/min)	Weight (kg)	Dimensions No.	Solenoids group	Model *1)
	G1/4	5/3 COE	Solenoid/Solenoid	3 ... 10	900	1,0	13	B	2623200
	G1/2	5/3 COE	Solenoid/Solenoid	2,5 ... 10	2200	1,6	14	B	2623700
	G1/4	5/3 APB	Solenoid/Solenoid	3 ... 10	900	1,0	13	B	2623300
	G1/2	5/3 APB	Solenoid/Solenoid	2,5 ... 10	2200	1,6	14	B	2623800
	G1/4	5/3 COP	Solenoid/Solenoid	3 ... 10	900	1,0	13	B	2623400

*1) When ordering please indicate solenoid, voltage and current type (frequency).
 APB = All Ports Blocked, COE = Centre Open Exhaust, COP = Centre Open Pressure

Solenoids, group A

	Power consumption 24 V d.c. 230 V a.c.		Rated current		Protection IP/NEMA	Protection Class (ATEX- Category)	Temperature Fluid-/ Ambient tem- perature:	Electrical connection	Weight (kg)	Dimensions No.	Circuit diagram No.	Model
	(W)	(VA)	24 V d.c. (m A)	230 V a.c. (m A)								
	1,8	—	70	—	IP65 (with Connector)	—	-15 ... +50	Connector DIN EN 175301-803 Form B *1)	0,1	1	1	3050
	1,6	—	30	—	IP65 (with Connector)	—	-15 ... +50	Connector DIN EN 175301-803 Form A *1)	0,1	2	1	3036
	2,7	—	115	—	IP65 (with Connector)	II 2 G Ex mb IIC T5 Gb II 2 D Ex mb tb T95°C Db	-20 ... +50 *2)	Connection cable 3 m	0,3	3	2	3062
	—	2,1	—	9	IP65 (with Connector)	II 2 G Ex mb IIC T5 Gb II 2 D Ex mb tb T95°C Db	-20 ... +50 *2)	Connection cable 3 m	0,3	3	3	3063
	2,7	—	115	—	IP66 (with Connector)	—	-10 ... +50	Connector *1) M12x1, DIN IEC 1076- 2-101 Magnetic coil with yellow LED	0,1	4	4	3071

Standard voltages (±10%) 24 V DC, 230 V AC. Standard voltages (±10%) 24 V d.c., 230 V a.c., other voltages on request.

*1) Connectors not included in the scope of delivery, see accessories

*2) Maximum +40°C for battery installation

Approval Solenoid operator, solenoids group B

	Power consumption 24 V d.c. 230 V a.c.		Rated current		Protection IP/NEMA	Protection Class (ATEX- Category)	Temperature Fluid-/ Ambient tem- perature:	Electrical connection	Weight (kg)	Dimensions No.	Circuit diagram No.	Model
	(W)	(VA)	24 V d.c. (m A)	230 V a.c. (m A)								
	4,8	8,5	70	—	IP65 (with Connector)	—	-15 ... +50	Connector DIN EN 175301-803 Form B *1)	0,1	1	1	3052
	4,4	8,0	190	—	IP65 (with Connector)	—	-15 ... +50	Connector DIN EN 175301-803 Form A *1)	0,1	2	1	3030
	5,0	—	210	—	IP65 (with Connector)	II 2 G Ex mb IIC T4/T5 Gb II 2 G Ex mb IIC T4 Gb II 2 D Ex mb tb T130°C Db	-20 ... +50 *2)	Cable length 3m	0,3	3	3	3060
	—	5	—	22	IP65 (with Connector)	II 2 G Ex mb IIC T4 Gb II 2 D Ex mb tb T130°C Db	-20 ... +50 *2)	Cable length 3m	0,3	3	3	3061

Ex e mb IIC T4 Gb Ex tb IIIC T120°C Db I IP 65 (with cable gland) Standard voltages (±10%) 24 V d.c., 230 V a.c., other voltages on request.

*1) Connectors not included in the scope of delivery, see accessories *2) Maximum +40°C for battery installation

Approvals

Model	Approvals				Data sheet
	ATEX	IECEX	FM	Inmetro certificate	
306x	PTB 03 ATEX 2015	—	—	Certificate DNV 15.0126	N/en 71.560

Accessories

Connector Form A	M12 x 1	Silencer	Flange plate	Temple
0570275 (Form A)	0523057 (2 m cable)	0523058 (90°, 2 m cable)	Page 10	Page 10
0680003 (Form B)	0523052 (5 m cable)	0523053 (90°, 5 m cable)	Page 10	0540593
			0612790 (NAMUR sub-base)	
			0612791 (NAMUR rib in combination with 0612790, aluminium)	

Dimensions Valves

Dimensions in mm
Projection / First angle



① ②

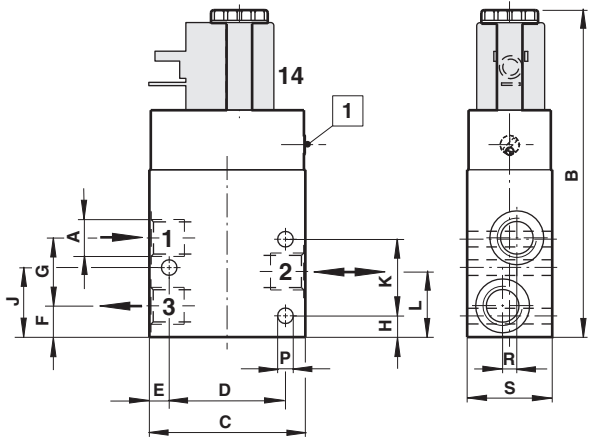

③

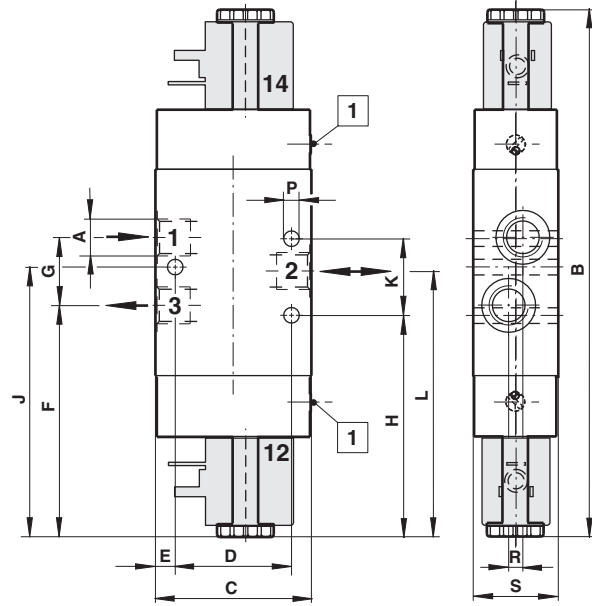

① Add-on manual
override

No.	A	B	C	D	E	F	G	H	J	K	L	ØP	R	S
1	G1/4	115,5	55	41	7	11	24	7,5	24,5	27	23	5,5	5	30
2	G1/2	143,5	65	46	9,5	29	33	31,5	-	46	50	7	2,5	35

① Add-on manual override

No.	A	B	C	D	E	F	G	H	J	K	L	ØP	R	S
3	G1/4	186,5	55	41	7	81,5	24	78	95	27	93,5	5,5	5	30

④

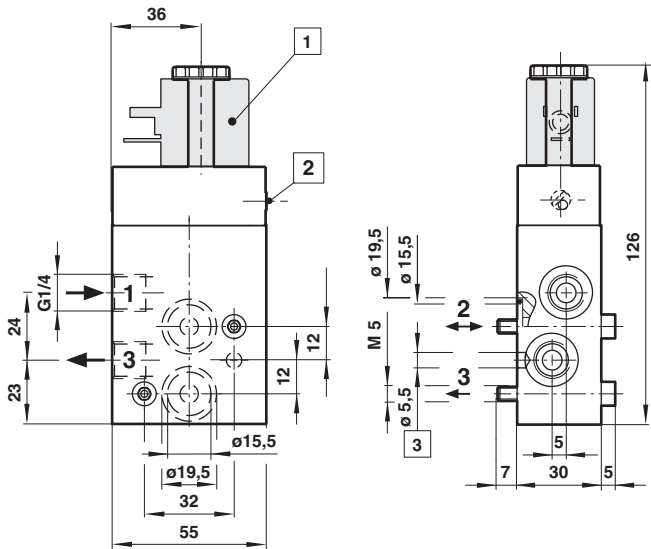

- ① Magnet can be rotated 90°
- ② Manual override with
- ③ latching Hole for NAMUR coding pin

5 6

Dimensions in mm
Projection / First angle

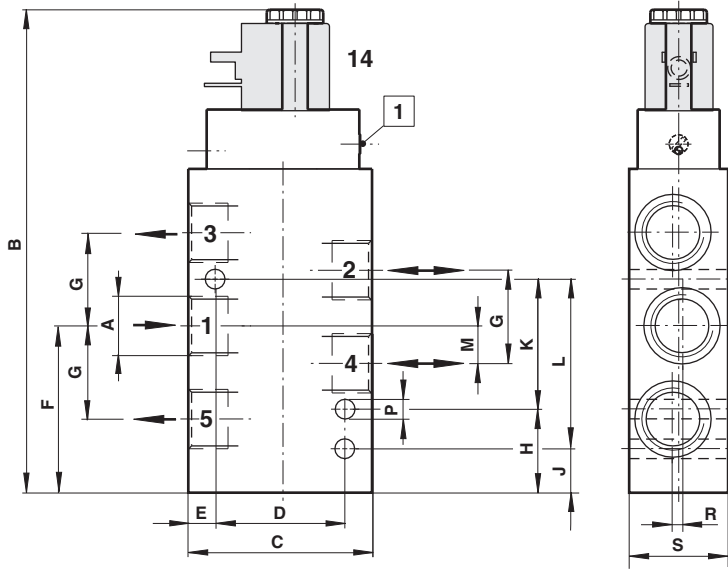

1 Add-on manual override

No.	A	B	C	D	E	F	G	H	J	K	L	M	ØP	R	S
5	G1/4	139,5	55	40	7,5	35	24	-	5	-	67	12	7	5	30
6	G1/2	171,5	65	46	9,5	59,5	33	30	16	46	60	13	7	3	35

7 8 13 14

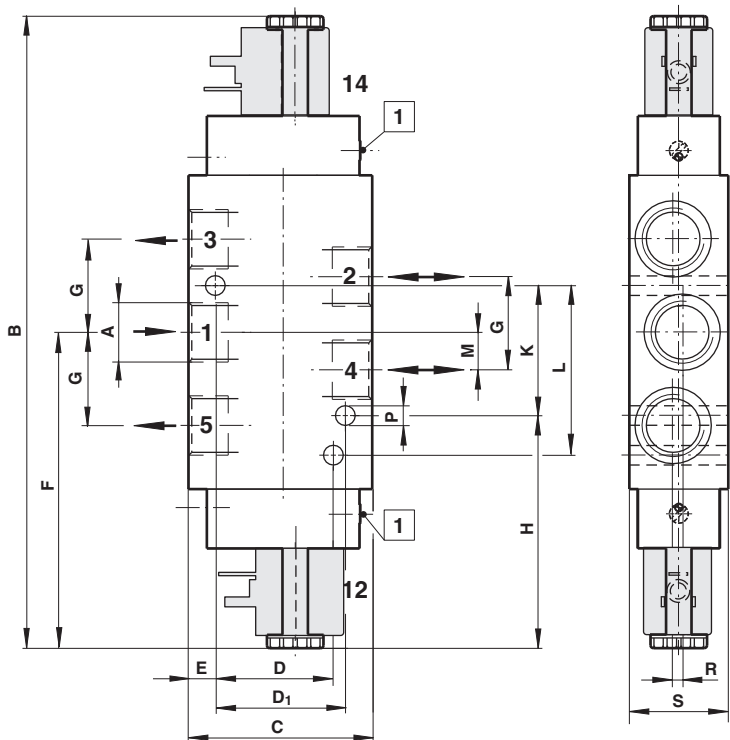

1 Add-on manual override

No.	A	B	C	D	D1	E	F	G	H	K	L	M	ØP	R	S
7	G1/4	214,5	55	40	40	7,5	107,5	24	77,5	67	-	12	7	5	30
8	G1/2	223,5	65	46	46	9,5	112	33	82,5	46	60	13	7	3	35
13	G1/4	232,5	55	40	40	7,5	118	24	88	67	-	12	7	5	30
14	G1/2	289	70	46	50	10	144,5	33	-	50	60	16,5	7	4	40

9

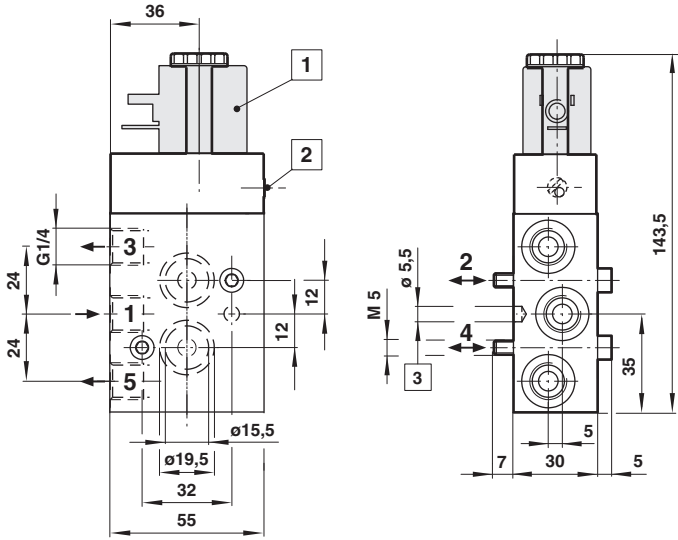

10

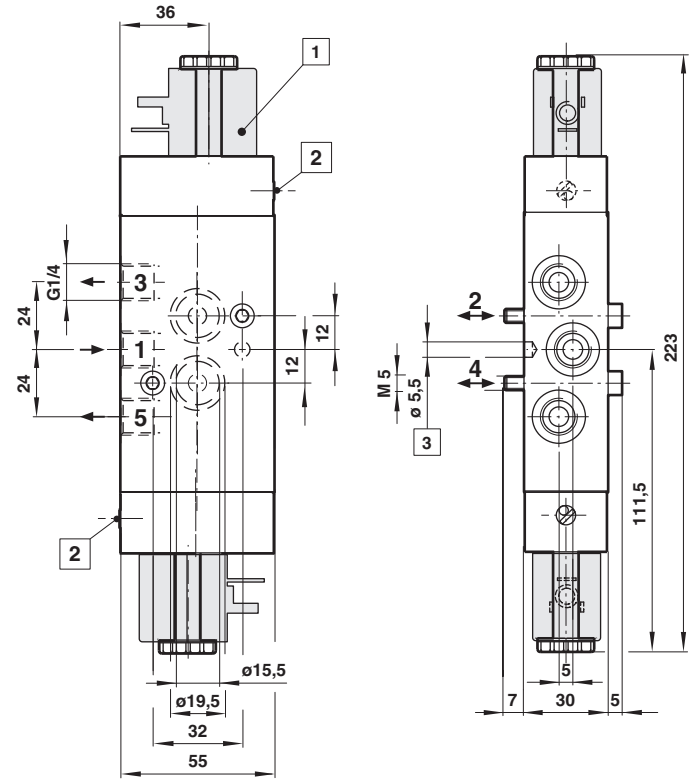

Dimensions in mm
Projection / First angle



11

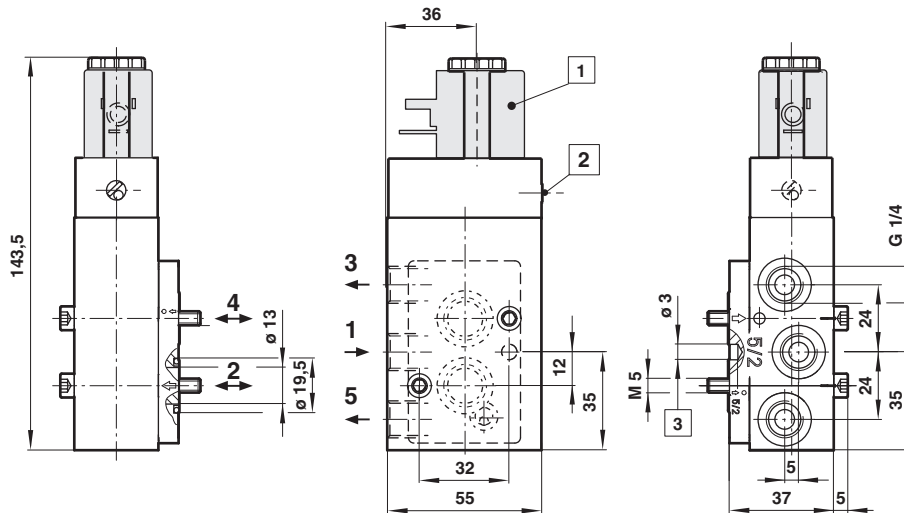

- 1 Magnet can be rotated 90°
- 2 Manual override with
- 3 latching Hole for NAMUR coding pin

Dimensions

Solenoid operators

Dimensions in mm
Projection / First angle



①

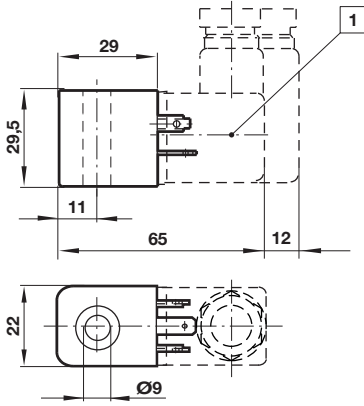

②

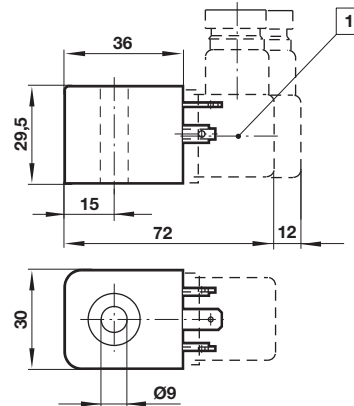

③

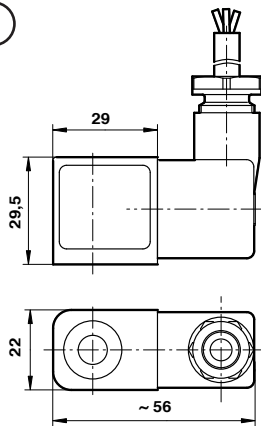

④

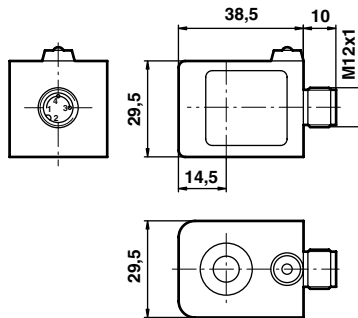

① Connector 4x90° rotatable

Electrical connection M 12 x 1



Pin	Signal	Cable
1	+ 24V DC (for diagnostics)	brown
2	Diagnostic feedback	white
3	0 volts	blue
4	24 V DC switching signal	black

Circuit diagrams

①

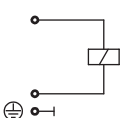

②

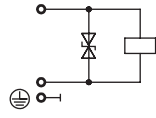

③

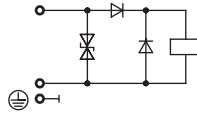

④

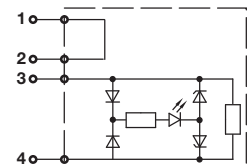

NAMUR hole pattern (drive side)

Dimensions in mm
Projection / First angle

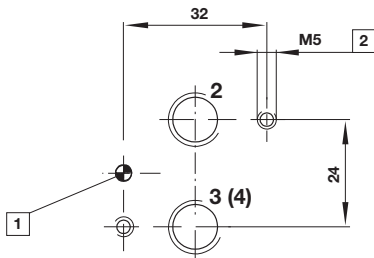

- 1 Threaded pin for a defined installation
- 2 position M5 (8 mm deep)

NAMUR quick air vent to achieve a higher kv value when venting, see data sheet 5.4.820

NAMUR sub-bases for redundant arrangement "Reliable ventilation" and "Reliable ventilation" see data sheet 5.4.830

Instructions for converting the function panel from 5/2 to 3/2-way function

5/2-way function (state of delivery)

3/2 way function

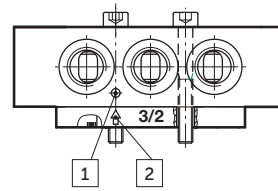
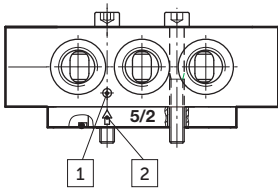

3/2 or 5/2-way functions can only be achieved by exchanging of the function plates can be achieved. Make sure the Markers and arrows match what is shown on the drawing. Original version of the delivery: 5/2-way function.

- 1 Arrow
- 2 Marker

Single connection plate
Type: 0612790

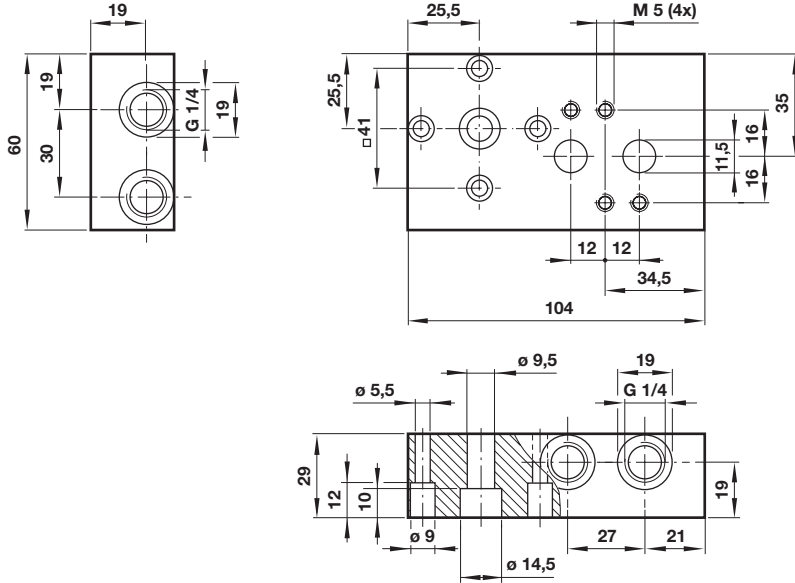

NAMUR rib
type: 0612791

Dimensions in mm
Projection / First angle

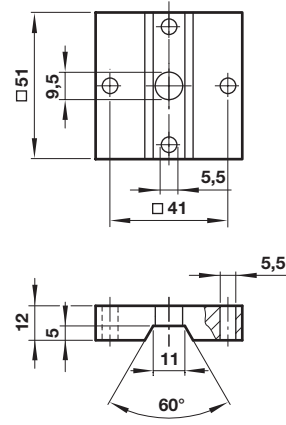

Bracket type: 0540593

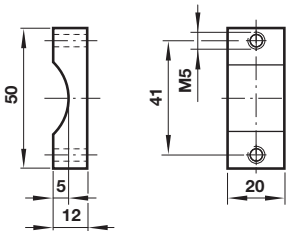
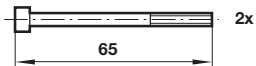

Silencer type: M/S2, M/S4

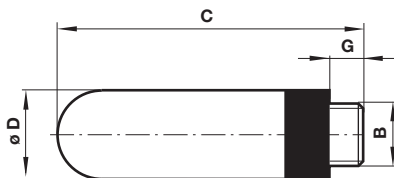

B	G	C	Ø D	Weight (kg)	Model
G1/4	7	35,5	15,5	2,9	M/S2
G1/2	12	67	23	11,5	M/S4

Sicherheitshinweise

Diese Produkte sind ausschließlich in Druckluftsystemen zu verwenden. Sie sind dort einzusetzen, wo die unter »Technische Merkmale/-Daten« aufgeführten Werte nicht überschritten werden. Berücksichtigen Sie bitte die entsprechende Katalogseite. Vor dem Einsatz der Produkte bei nicht industriellen Anwendungen, in lebenserhaltenden oder anderen Systemen, die nicht in den veröffentlichten Anleitungsunterlagen enthalten sind, wenden Sie sich bitte direkt an Norgren.

Durch Missbrauch, Verschleiß oder Störungen können in Fluidsystemen verwendete Komponenten auf verschiedene Arten versagen. Systemauslegern wird dringend empfohlen, die Störungsarten aller in Hydrauliksystemen verwendeten Komponententeile zu berücksichtigen und ausreichende Sicherheitsvorkehrungen zu treffen, um Verletzungen von Personen sowie Beschädigungen der Geräte im Falle einer solchen Störung zu verhindern. Systemausleger sind verpflichtet, Sicherheitshinweise für den Endbenutzer im Betriebshandbuch zu vermerken, wenn der Störungsschutz nicht ausreichend gewährleistet ist.