

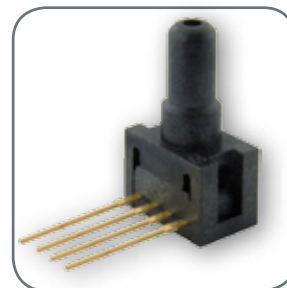

## Miniature Low Pressure Sensors **26PC Series, Compensated/Unamplified** 1 psi to 250 psi



# Miniature Low Pressure Sensors

The 26PC Series Miniature Pressure Sensors are small, cost-effective devices intended for use with wet or dry media. These sensors feature proven sensing technology that uses a specialized piezoresistive micromachined sensing element to offer high performance, reliability, and accuracy. Each sensor contains four active piezoresistors that form a Wheatstone bridge. When pressure is applied, the resistance changes and the sensor provides a milliVolt output signal that is proportional to the input pressure.

The low power 26PC sensors are designed to accommodate pressures from 1 psi to 250 psi and have an operating temperature range of -40 °C to 85 °C [-40 °F to 185 °F].

These sensors can accommodate a variety of wet and dry media that are compatible with polyphthalamide (PPA) plastics and media seals specified in the Nomenclature and Order Guide (see Figure 2). The 26PC sensors are RoHS compliant. They are designed and manufactured according to ISO 9001 standards.

## What makes our sensors better?

- Wet/Wet capability (i.e., liquids on both ports)
- Selectable seals available to match media used
- Higher pressure ranges for use in high pressure applications
- Wide variety of pressure port types
- Available in both SIP and DIP packages

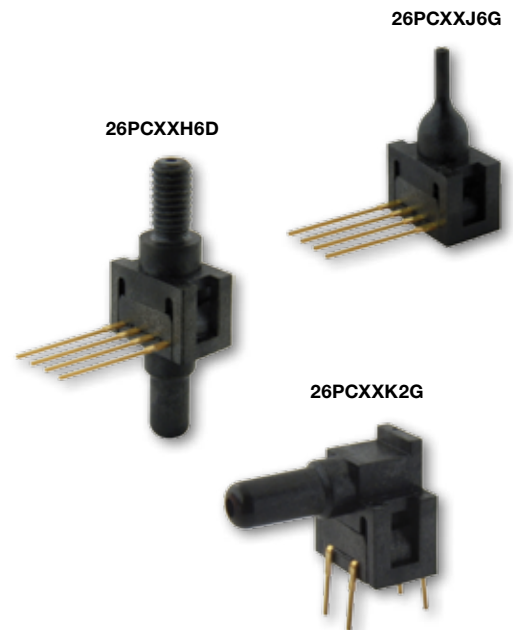

For all available configurations, see Table 4.

## Features and Benefits

### *One sensor does the work of two!*

#### **TRUE WET/WET DIFFERENTIAL MEDIA SENSING**

Provides liquid sensing in differential applications

#### **WIDE OPERATING TEMPERATURE RANGE OF -40 °C TO 85 °C [-40 °F TO 185 °F]**

Allows use in a wide variety of applications

### *By matching pressure ranges to the application, we optimize resolution and improve system accuracy.*

#### **VARIETY OF PRESSURE RANGES WITHIN 1 PSI TO 250 PSI**

Provides flexibility in customers' pneumatic designs

#### **ABSOLUTE, DIFFERENTIAL, AND GAGE MEASUREMENT TYPES**

Allows customers to choose the sensor that fits their application

### *Gives customers greater system flexibility in their designs.*

#### **VARIETY OF PRESSURE PORT TYPES AND LEAD TERMINATIONS**

Provides application flexibility

#### **ALSO AVAILABLE IN SMT AND FLOW-THROUGH PACKAGE STYLES**

Provides added design flexibility

# Potential Applications



## MEDICAL

---

### OXYGEN CONCENTRATORS

May be used to measure the sieve bed pressure to optimize system performance

### DENTAL CHAIRS

May be used to control the pneumatic pressure in the various dental instruments

### HEMODIALYSIS

May be used to monitor the correct pressure to help ensure optimum blood filtration



## INDUSTRIAL

---

### WATER CONTROL VALVES

May be used to monitor the water consumption in homes and buildings

### IRRIGATION EQUIPMENT

May be used to control the water pressure and flow being delivered

### FILTER MONITORING

May be used to detect when the filters are clogged and need to be replaced

### PRESSURE VALVES

May be used to measure and control pressure in industrial processes



### AIR COMPRESSORS

May be used to control the pressure being delivered to the end user equipment

### BREATHALIZERS

May be used to measure the exhalation pressure to ensure proper breath analysis

# 26PC Series, Compensated/Unamplified

**Table 1. Absolute Maximum Ratings<sup>1</sup>**

Characteristic	Min.	Typ.	Max.	Unit	Note
Supply voltage	2.5	10	16	Vdc	–
Input resistance	5.5	7.5	11.5	kOhm	–
Output resistance	1.5	2.5	3	kOhm	–
Time response	–	–	1	ms	2

<sup>1</sup>Absolute maximum ratings are the extreme limits the device will withstand without damage.

<sup>2</sup>Time required for the output to increase from 10% to 90% of span in response to a step change in input pressure from the specified min. to max. operating pressure.

**Table 2. Technical Specifications**

Characteristic	Parameter
Operating temperature range: without EPDM seals with EPDM seals	-40 °C to 85 °C [-40 °F to 185 °F] -20 °C to 85 °C [-4 °F to 185 °F]
Compensated temperature range	0 °C to 50 °C [32 °F to 122 °F]
Storage temperature range	-55 °C to 100 °C [-67 °F to 212 °F]
Soldering terminal temperature/time	315 °C [599 °F] max./10 s max.
Vibration	10 G at 20 Hz to 2000 Hz
Shock	100 G for 11 ms
Life	1 million cycles min.

# Miniature Low Pressure Sensors

**Table 3. Performance Characteristics (Vcc =10.00 ±0.01 Vdc; Ta = 25 °C [77 °F])**

Characteristic	0 psi to 1 psi		0 psi to 5 psi		0 psi to 15 psi		0 psi to 30 psi		0 psi to 100 psi		0 psi to 250 psi		Unit	Note
	Typ.	Max.	Typ.	Max.	Typ.	Max.	Typ.	Max.	Typ.	Max.	Typ.	Max.		
Span	–	16.7 ±2	–	50 ±3	–	100 ±3	–	100 ±3	–	100 ±3	–	150 ±7	mV	1
Null offset	–	0 ±1.5	–	0 ±1.5	–	0 ±1.5	–	0 ±1.5	–	0 ±2.0	–	0 ±2.0	mV	2
Linearity (Best Fit Straight Line, P2>P1)	0.25	0.5	0.4	0.5	0.25	0.5	0.1	0.2	0.4	0.6	0.5	0.7	%span	3
Null shift (0 °C to 25 °C, 25 °C to 50 °C)	±0.5	±1.0	±0.5	±1.0	±0.5	±1.0	±0.75	±1.5	±1.0	±2.0	±1.0	±2.0	mV	4
Span shift (0 °C to 25 °C, 25 °C to 50 °C)	±1.0	±2.0	±1.0	±1.5	±0.75	±1.5	±0.75	±1.5	±0.5	±1.5	±0.5	±1.5	%span	5
Repeatability and hysteresis	±0.5	–	±0.2	–	±0.2	–	±0.2	–	±0.2	–	±0.2	–	mV	6
Overpressure	–	20	–	20	–	45	–	60	–	200	–	500	psi	7

<sup>1</sup>Span is the algebraic difference between the output signal measured at the upper and lower limits of the operating pressure range, where Port 2 (P2)>Port 1 (P1).

<sup>2</sup>The output signal obtained when zero pressure is applied to all available ports.

<sup>3</sup>The maximum deviation of product output from a straight line fitted to the output measured over the specified operating pressure range, calculated according to BFSL. The straight line is fitted along a set of points that minimizes the sum of the square of the deviations of each of the points (“least-squares” method).

<sup>4</sup>The maximum deviation in offset due to changes in temperature over the compensated temperature range, relative to offset measured at a reference temperature of 25 °C.

<sup>5</sup>The maximum deviation in span due to changes in temperature over the compensated temperature range, relative to full-scale span measured at a reference temperature of 25 °C.

<sup>6</sup>Repeatability is the maximum difference between the output readings when the same pressure is applied consecutively, under the same operating conditions, with pressure approaching from the same direction within the specified operating pressure range. Hysteresis is the maximum difference between output readings when the same pressure is applied consecutively, under the same operating conditions, with pressure approaching from opposite directions within the specified operating pressure range.

<sup>7</sup>Overpressure is the maximum pressure that may safely be applied to the product for it to remain in specification once pressure is returned to the operating pressure range. Exposure to higher pressures may cause permanent damage to the product. Unless otherwise specified, this applies to all available pressure ports at any temperature within the operating temperature range.

**Figure 1. Circuit Diagram**

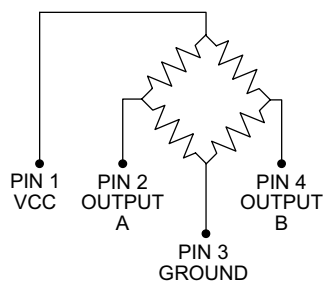

Output “A” increases as P2 pressure increases.

Output “B” decreases as P2 pressure increases.

Symbol	Description
Vcc	supply
OUTPUT A	bridge positive output
GROUND	ground
OUTPUT B	bridge negative output

# 26PC Series, Compensated/Unamplified

Figure 2. Nomenclature and Order Guide<sup>1,4</sup>

For example, a **26PCBEJ6G** catalog listing defines a 26PC Series Miniature Low Pressure Sensor, Compensated/Unamplified, 5 psi pressure range, EPDM seal material, needle pressure port type, 1 x 4 SIP, 15,2 mm [0.60 in] long termination configuration, with normal polarity output and gage pressure measurement type.

<b>26PC</b>	<b>B</b>	<b>E</b>	<b>J</b>	<b>6G</b>
Product Series	Pressure Range	Seal Material	Pressure Port Type	Termination Configuration, Output, Pressure Measurement Type
<b>26PC Series Miniature Low Pressure Sensors, Compensated/Unamplified</b>	<b>A</b> 1 psi	<b>F</b> fluorosilicone	<b>A</b> Straight	<b>6D</b> 1 x 4 SIP, 15,2 mm [0.60 in] long, normal polarity, differential
	<b>B</b> 5 psi	<b>E</b> EPDM	<b>B</b> Barbed	<b>6G</b> 1 x 4 SIP, 15,2 mm [0.60 in] long, normal polarity, gage
	<b>C</b> 15 psi	<b>N</b> neoprene <sup>2</sup>	<b>C</b> Luer	<b>1G</b> 1 x 4 SIP, 10,2 mm [0.40 in] long, normal polarity, gage
	<b>D</b> 30 psi		<b>D</b> Modular	<b>2G</b> 2 x 2 DIP, normal polarity, gage
	<b>F</b> 100 psi		<b>H</b> M5 thread port	
	<b>G</b> 250 psi		<b>I</b> 90° (opposite Pin 1)	
			<b>J</b> Needle	
		<b>K</b> 90° (toward Pin 1)		
		<b>M</b> 1/4-28 thread		
		<b>S</b> Manifold mount		
		<b>T</b> Long barbed		















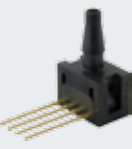
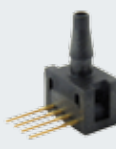





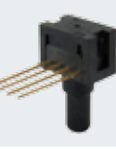
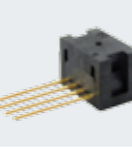





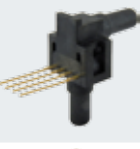
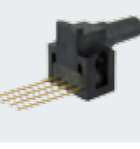





<sup>1</sup>Every combination may not be possible. Contact customer service.

<sup>2</sup>Available in 1 psi, 5 psi and 15 psi pressure ranges only.

<sup>3</sup>Absolute pressure sensors require pressure port types A or D.

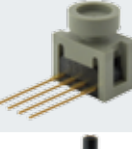
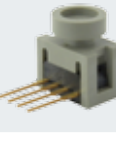
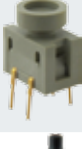
# Miniature Low Pressure Sensors

Table 4. All Available Standard Configurations (See Figure 2.)

		Termination Configuration, Output, Pressure Measurement Type			
		6D	6G	1G	2G
Pressure Port Type	A Straight			N/A	
	B Barbed				
	C Luer				
	D Modular			N/A	
	H M5 Thread				
	I 90° (Opposite Pin 1)			N/A	N/A
	J Needle			N/A	
	K 90° (Toward Pin 1)			N/A	
	M 1/4-28 Thread				
	S Manifold Mount				
	T Long Barbed			N/A	

# 26PC Series, Compensated/Unamplified

Figure 3. Mounting Dimensions (For Reference Only: mm/[in.])

## 26PCXXA6D

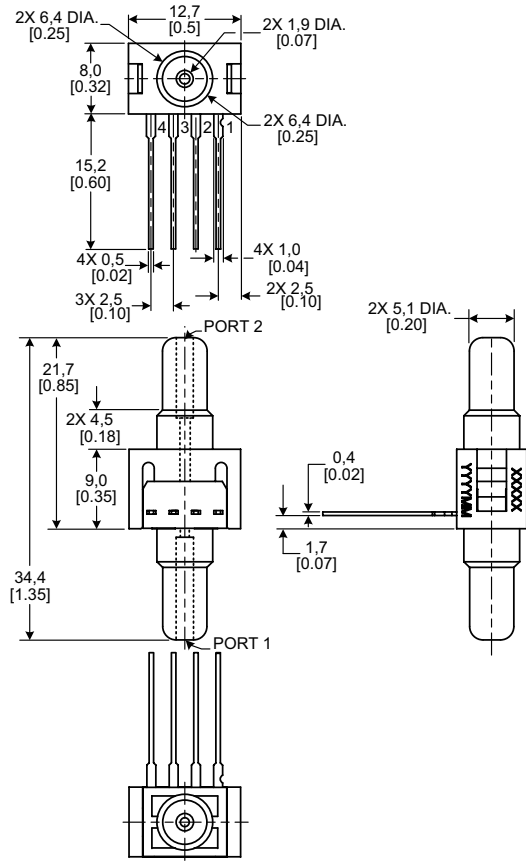

## 26PCXXA6G

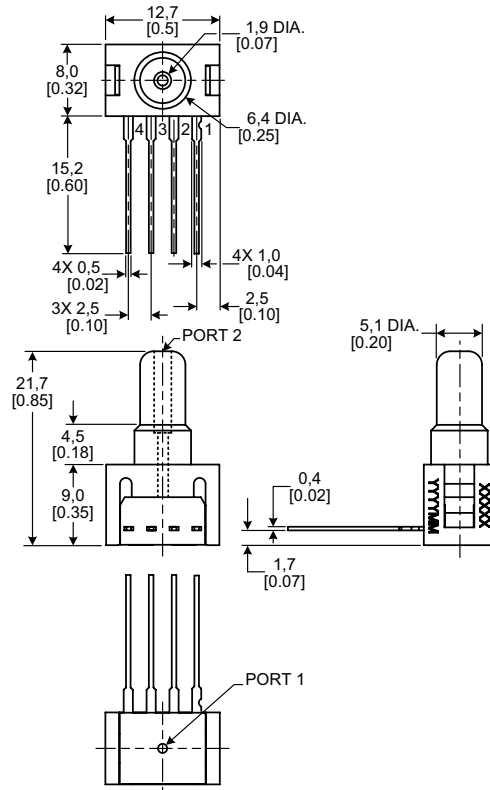

## 26PCXXA2G

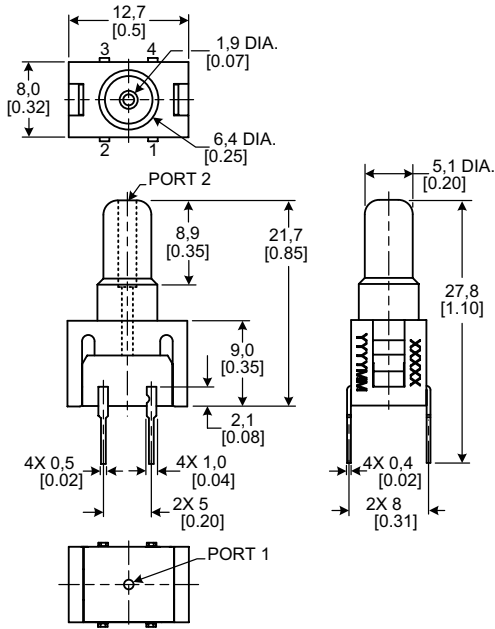

## 26PCXXB6D

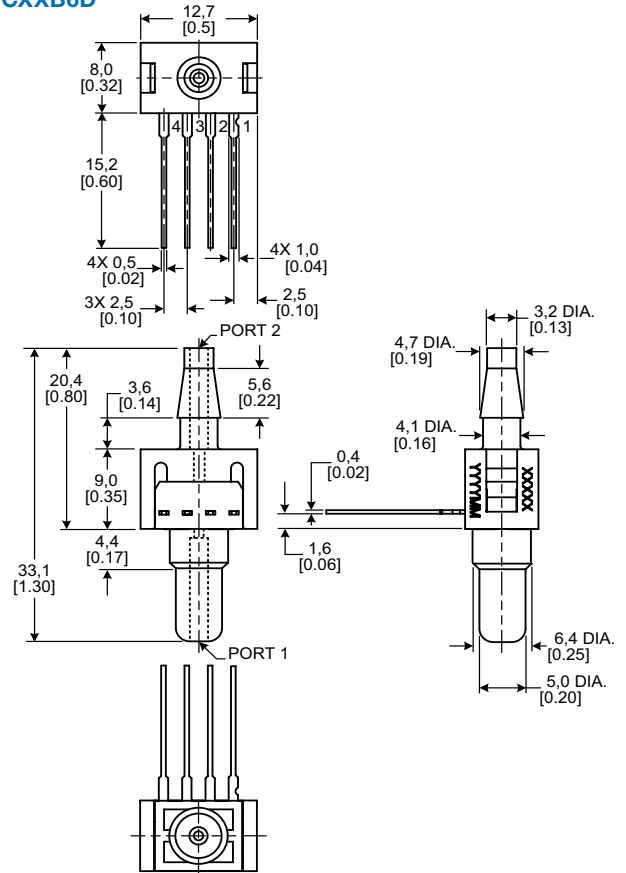

# Miniature Low Pressure Sensors

Figure 3. Mounting Dimensions (continued)

## 26PCXXB6G

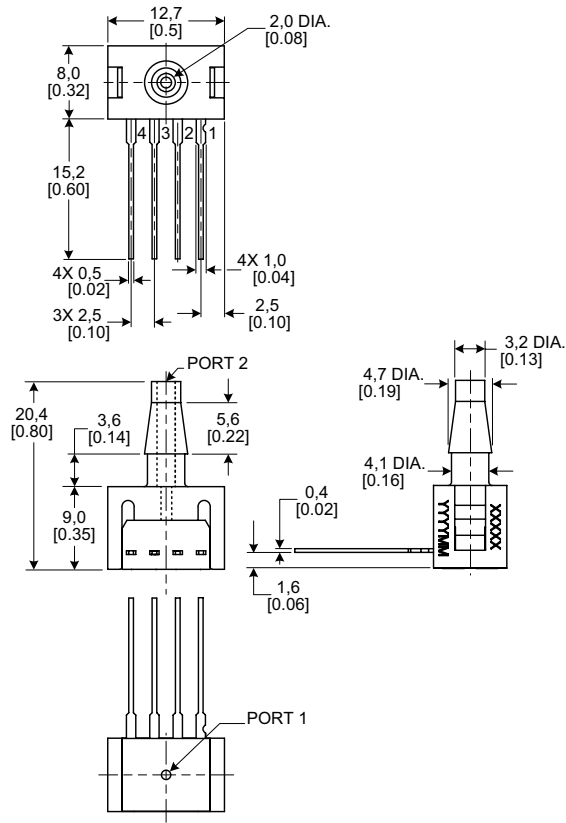

## 26PCXXB1G

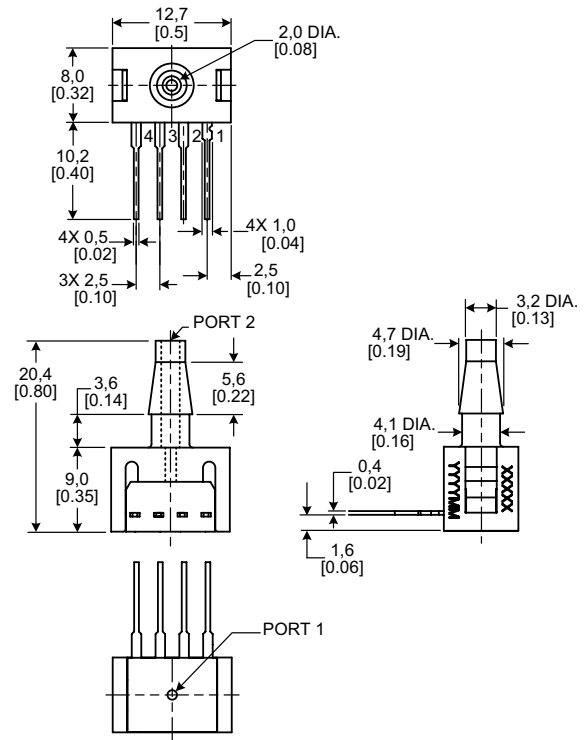

## 26PCXXB2G

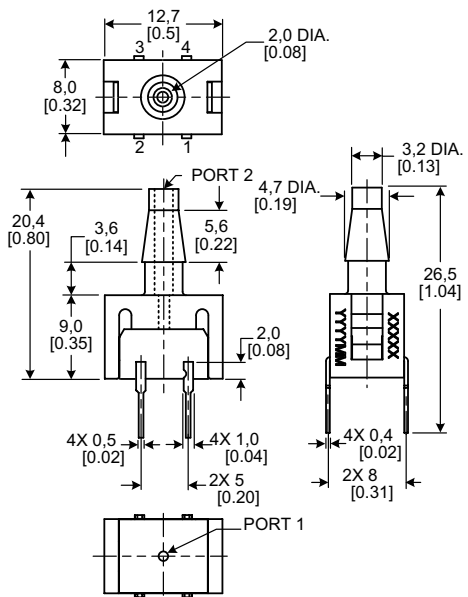

## 26PCXXC6D

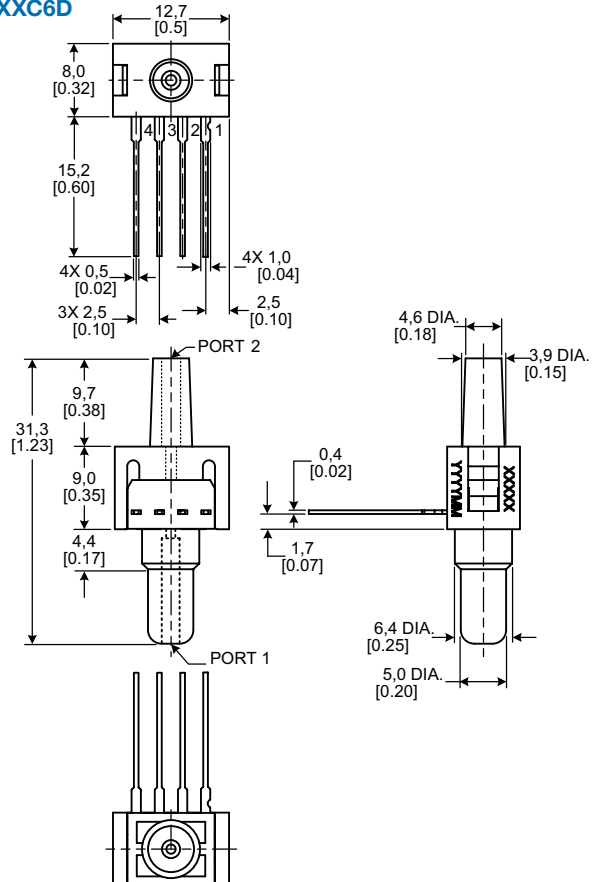

# 26PC Series, Compensated/Unamplified

Figure 3. Mounting Dimensions (continued)

## 26PCXXC6G

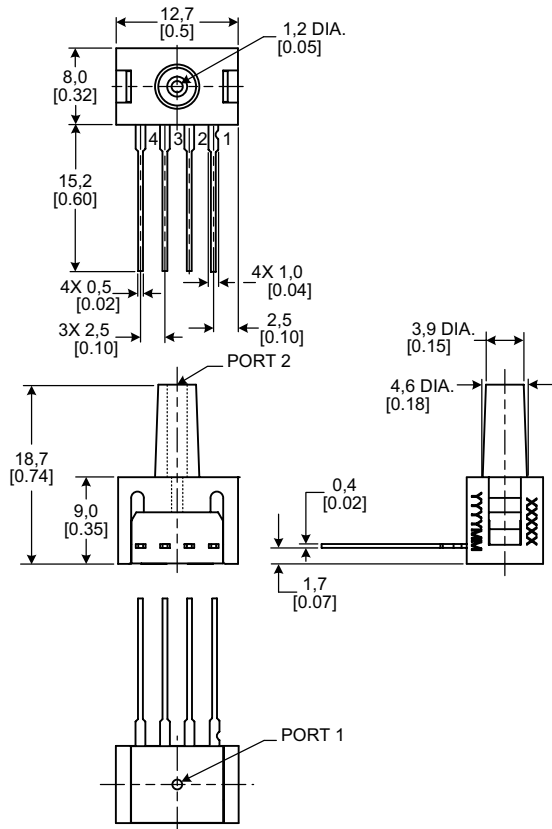

## 26PCXXC1G

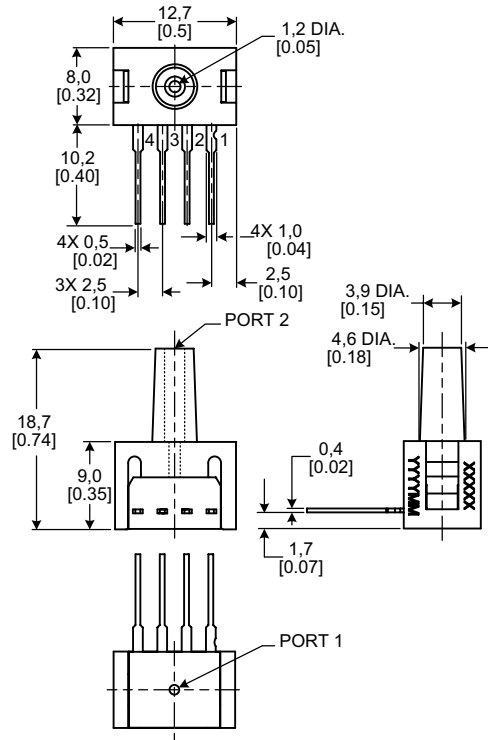

## 26PCXXC2G

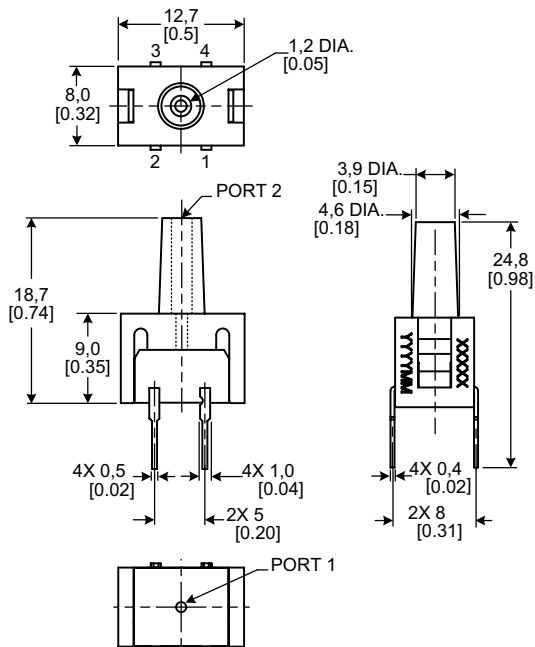

## 26PCXXD6D

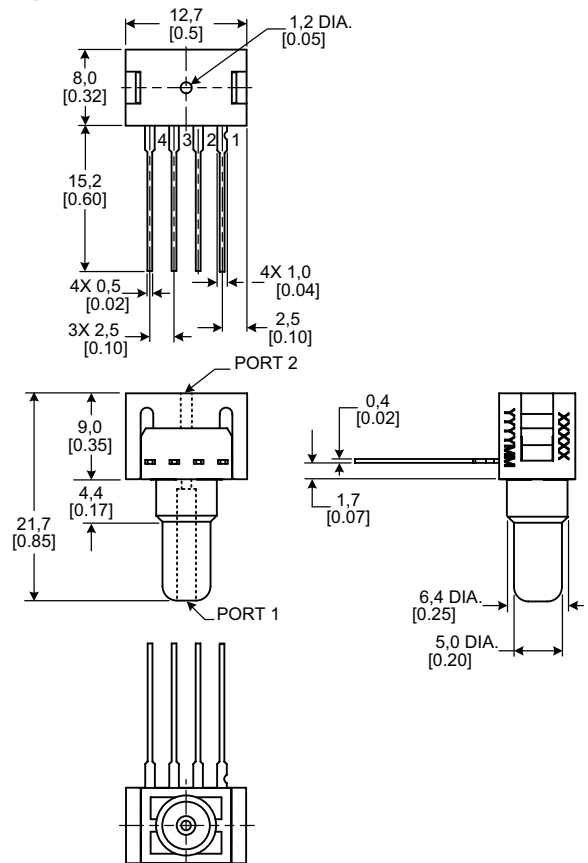

# Miniature Low Pressure Sensors

Figure 3. Mounting Dimensions (continued)

## 26PCXXD6G

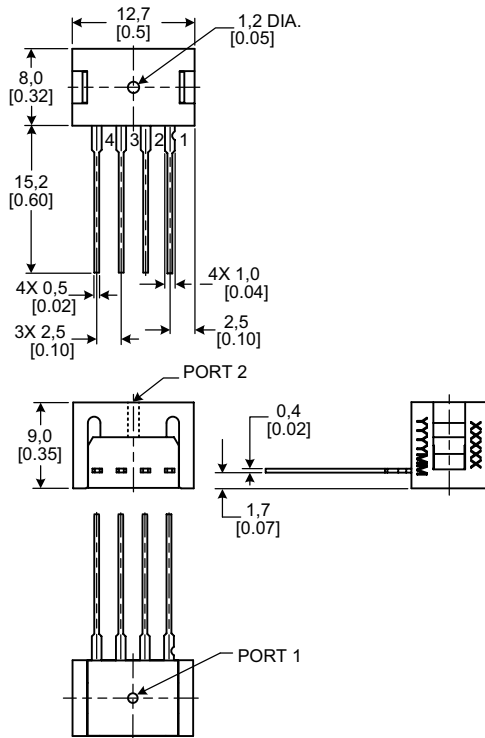

## 26PCXXD2G

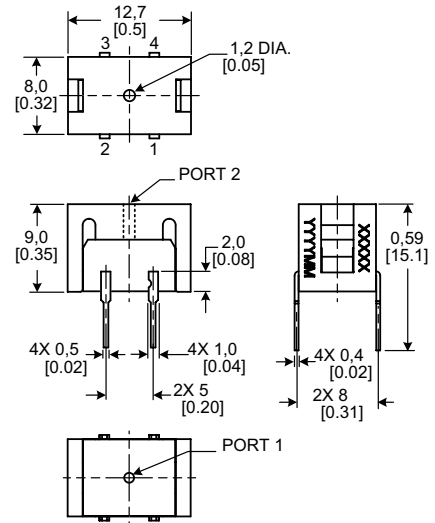

## 26PCXXH6D

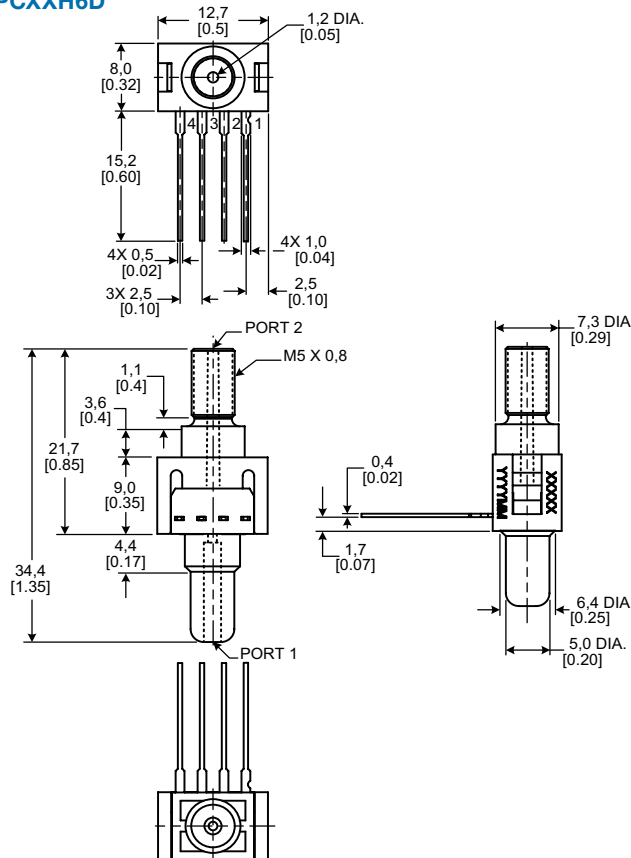

## 26PCXXH6G

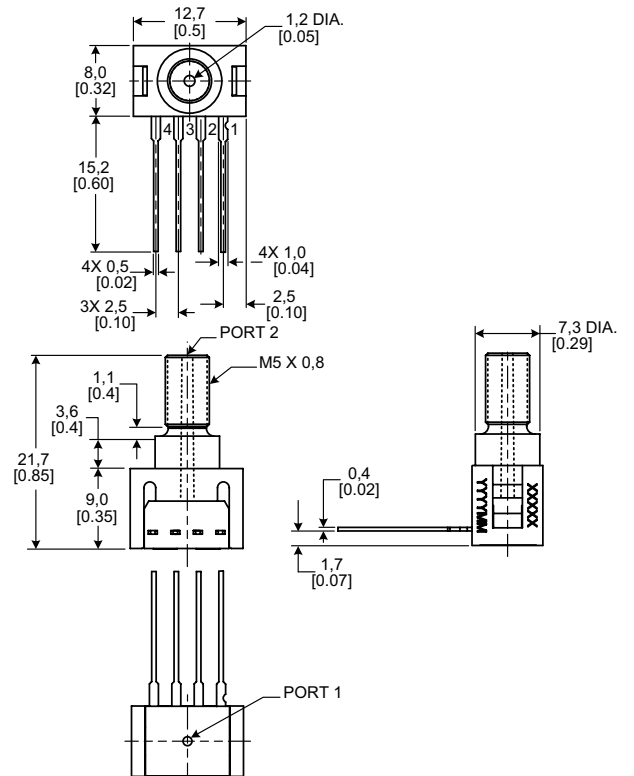

# 26PC Series, Compensated/Unamplified

Figure 3. Mounting Dimensions (continued)

## 26PCXXH1G

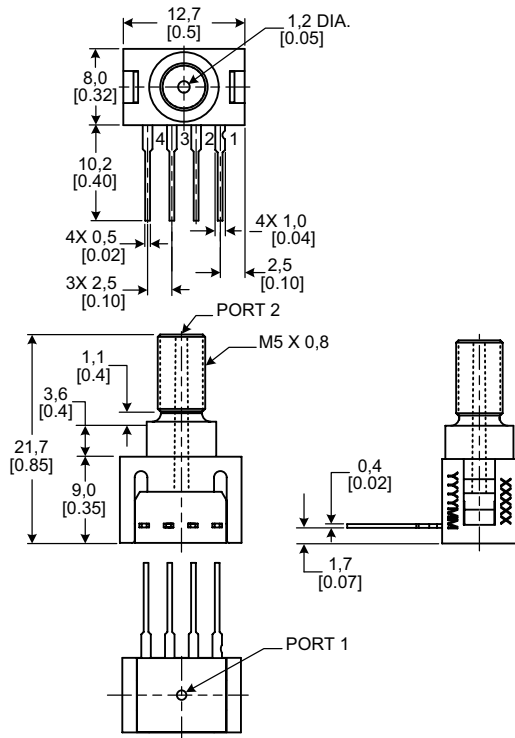

## 26PCXXH2G

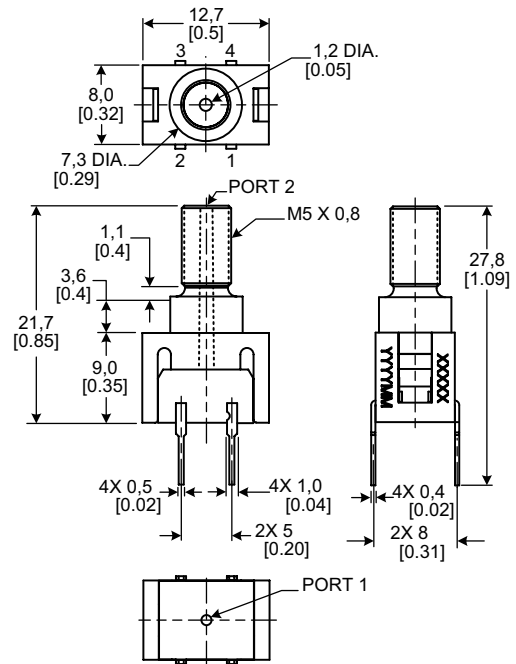

## 26PCXXI6D

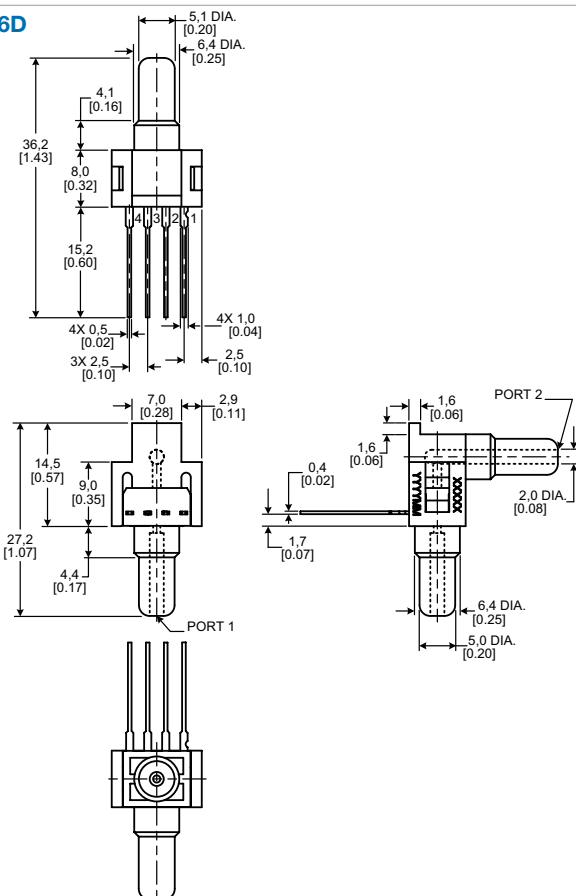

## 26PCXXI6G

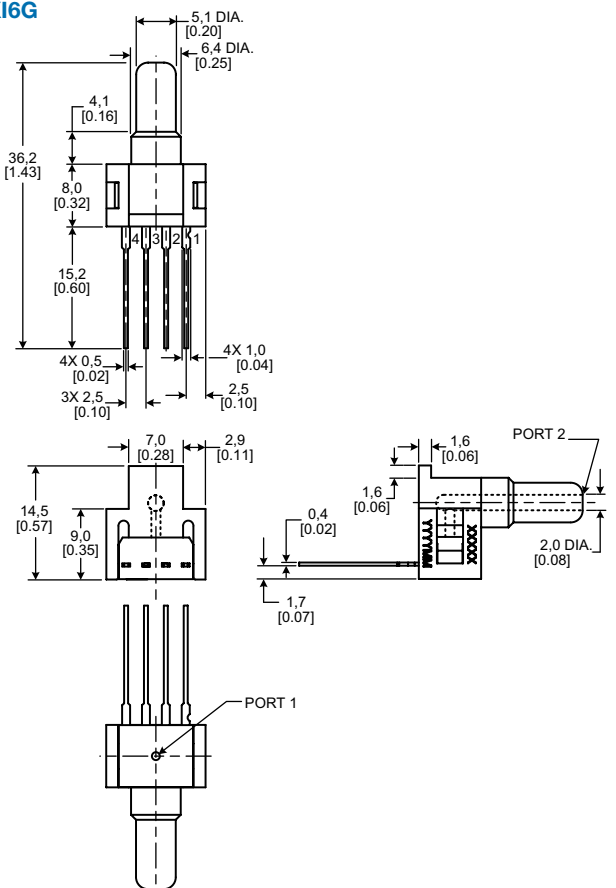

# Miniature Low Pressure Sensors

Figure 3. Mounting Dimensions (continued)

## 26PCXXJ6D

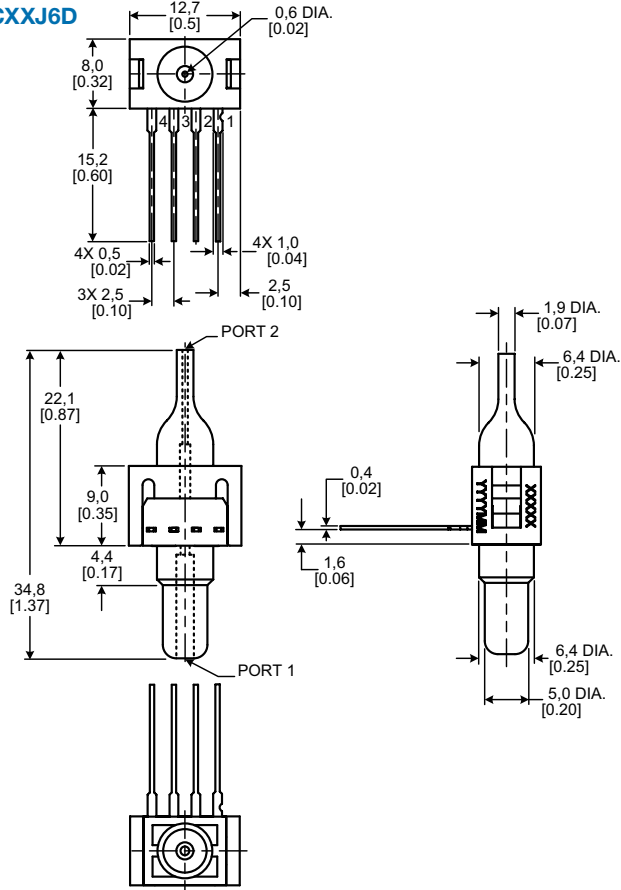

## 26PCXXJ6G

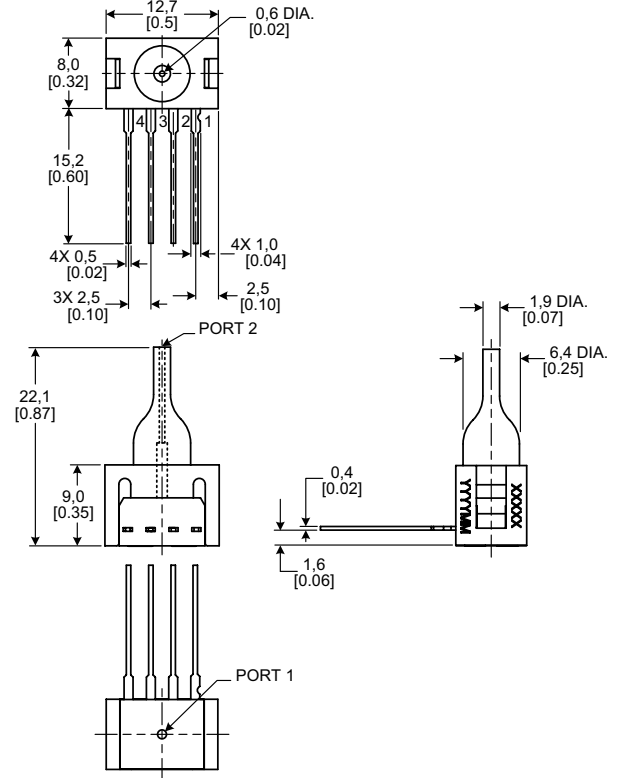

## 26PCXXJ2G

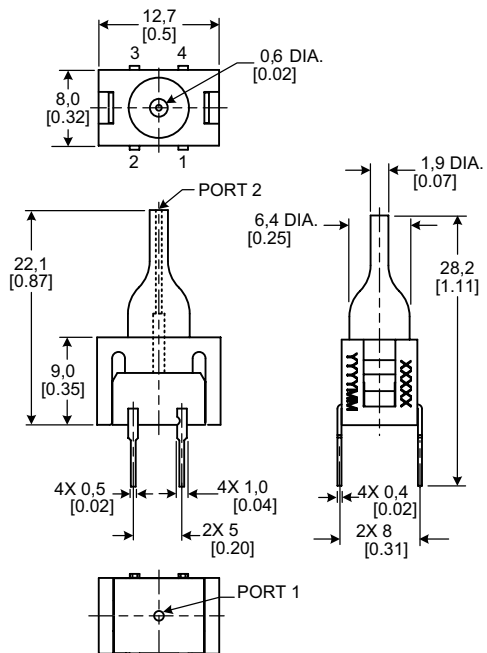

## 26PCXXK6D

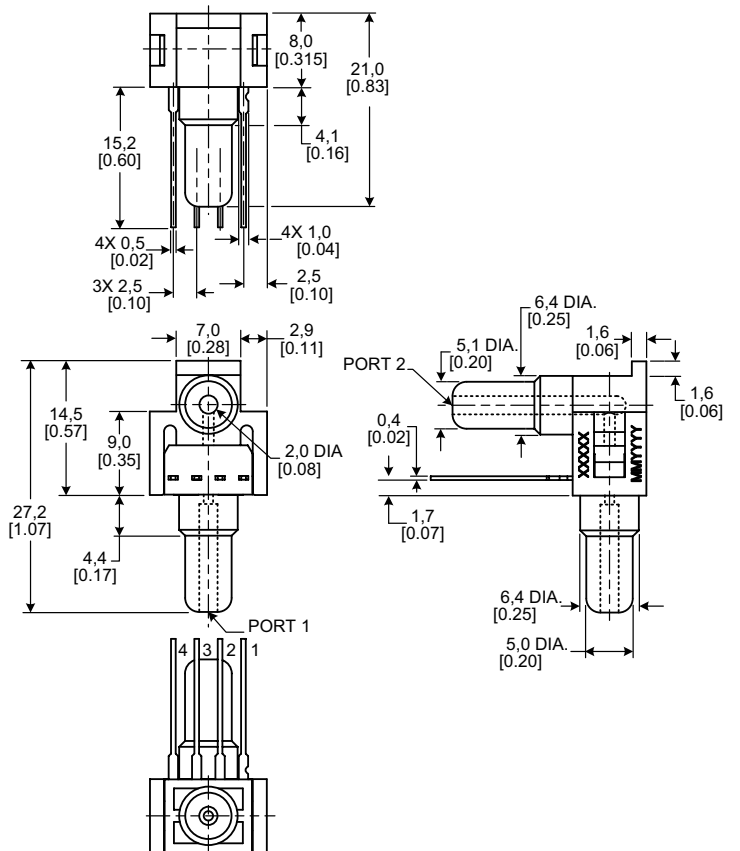

# 26PC Series, Compensated/Unamplified

Figure 3. Mounting Dimensions (continued)

## 26PCXXK6G

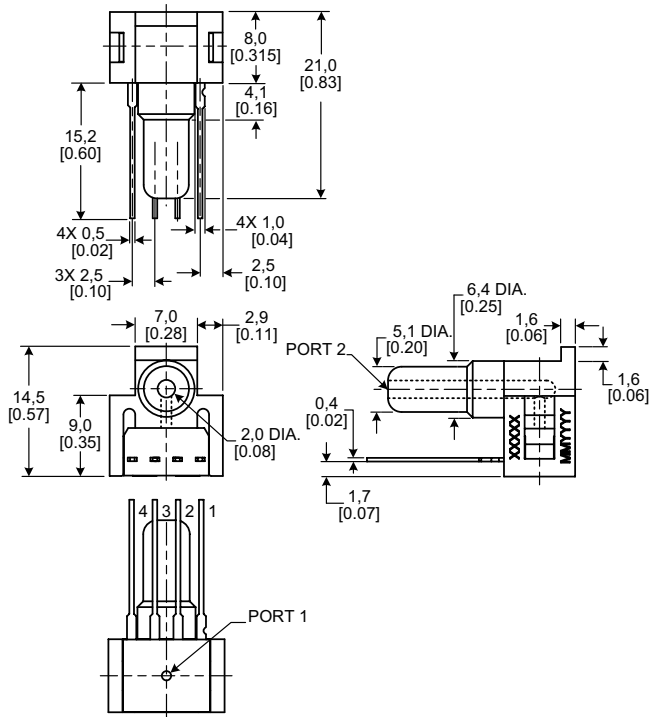

## 26PCXXK2G

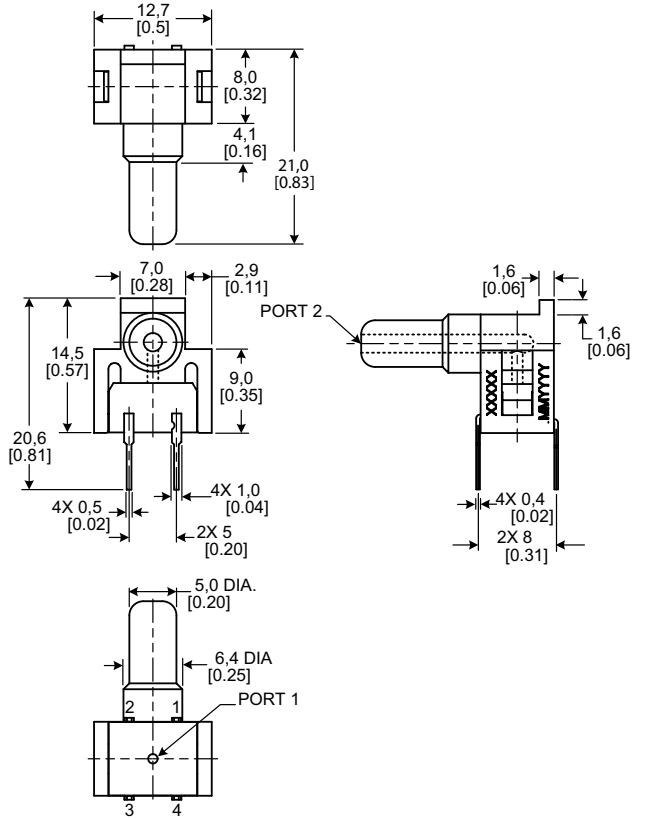

## 26PCXM6D

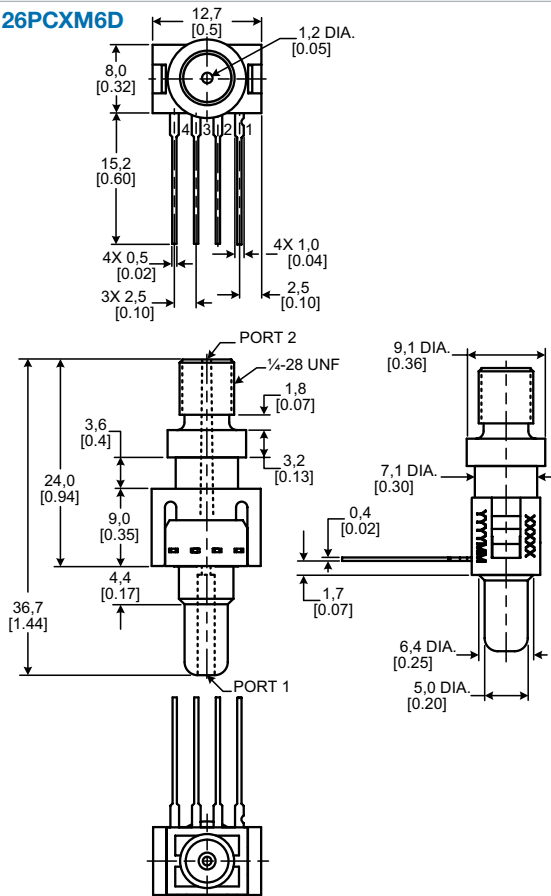

## 26PCXXM6G

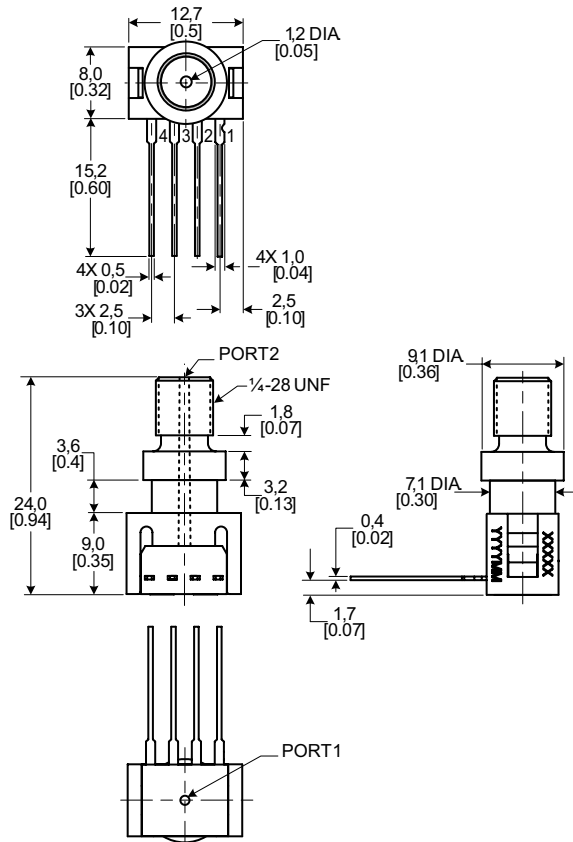

# Miniature Low Pressure Sensors

Figure 3. Mounting Dimensions (continued)

## 26PCXXM1G

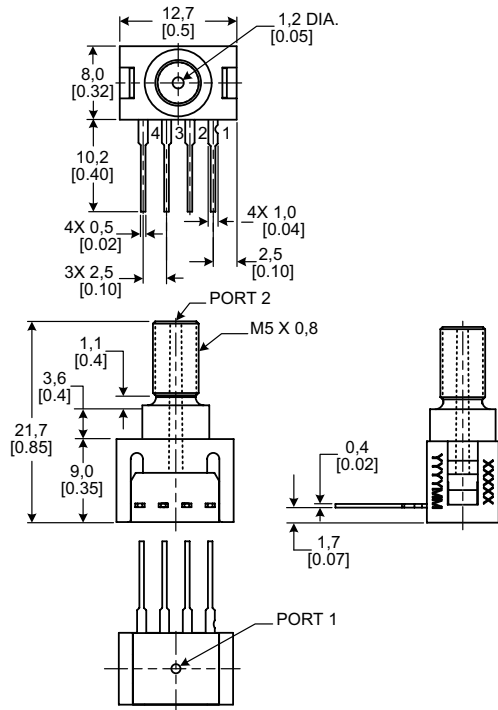

## 26PCXXM2G

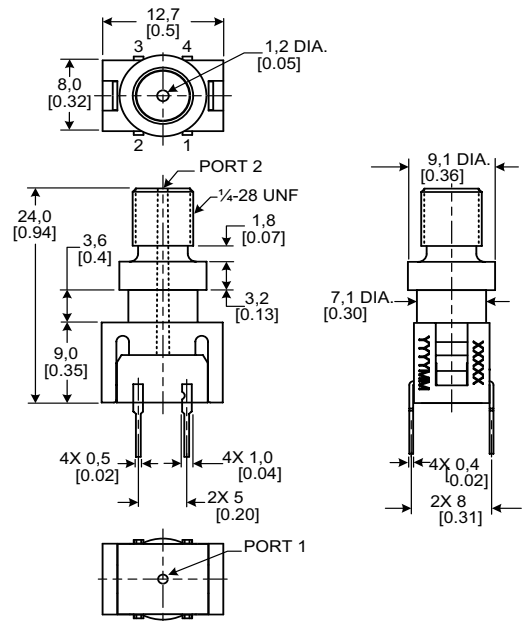

## 26PCXXS6D

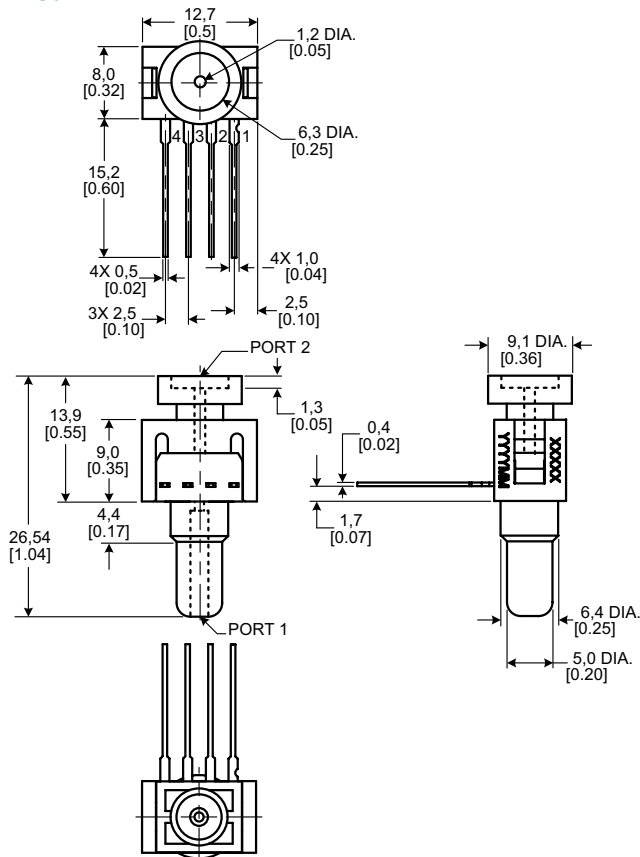

## 26PCXXS6G

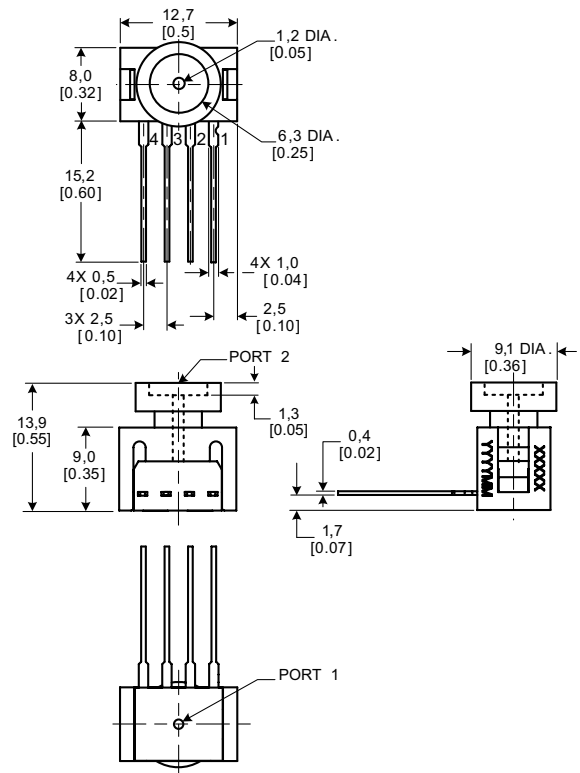

# 26PC Series, Compensated/Unamplified

Figure 3. Mounting Dimensions (continued)

## 26PCXXS1G

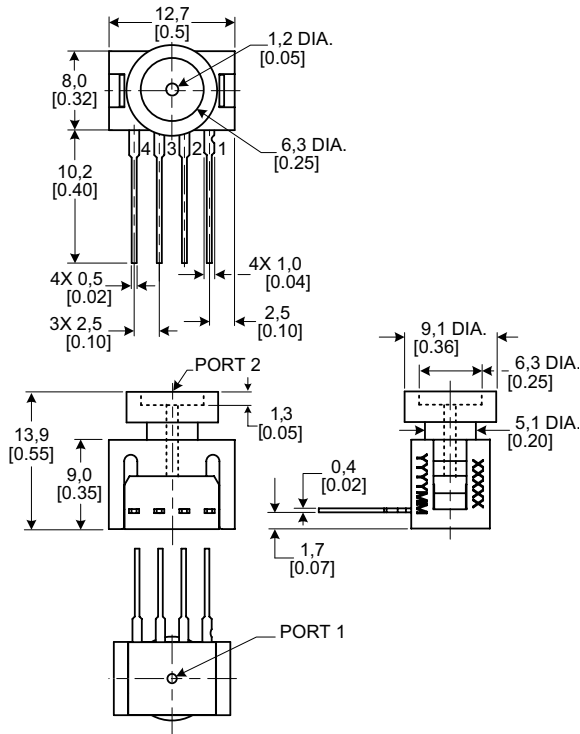

## 26PCXXS2G

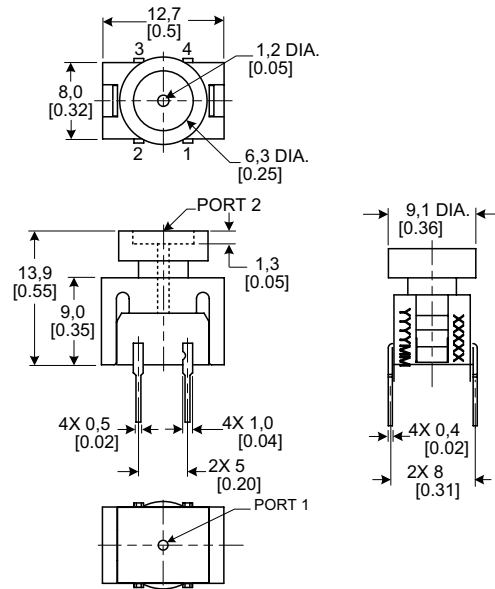

## 26PCXXT6D

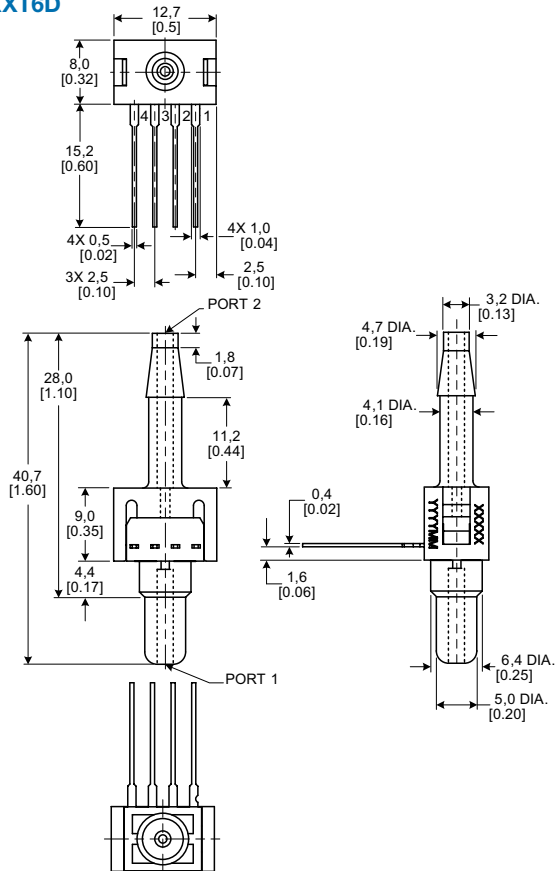

## 26PCXXT6G

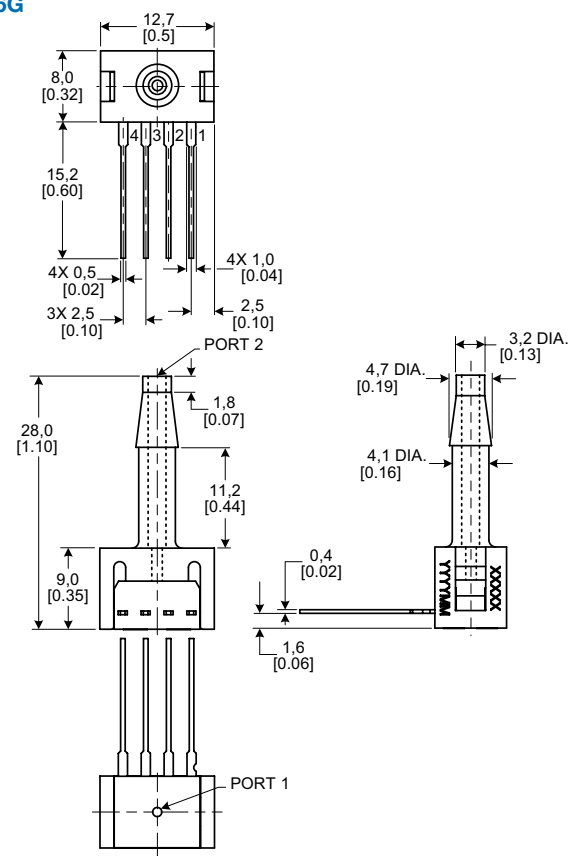

# Miniature Low Pressure Sensors

Figure 3. Mounting Dimensions (continued)

26PCXXT2G

