

Fixed Displacement Plug-In Motor A2FE

RE 91 008/04.05 1/16
Replaces: 03.97

Technical data sheet

Series 6	
Sizes	Nominal pressure/Peak pressure
23...180	400/450 bar
250...355	350/400 bar
Open and closed circuits	



Contents

Ordering Code / Standard Program	2...3
Technical Data	4...6
Unit Dimensions, Sizes 23...180	7...8
Unit Dimensions, Size 250	9
Unit Dimensions, Size 355	10
Flushing and Boost Pressure Valve	11
Pressure Relief Valves	12
Counterbalance Valve BVD	13
Speed Measurement	14
Installation and Commissioning Notes	15
General Notes	16

Features

- Fixed displacement motor with axial tapered piston rotary group of bent axis design, suitable for hydrostatic drives in open and closed circuits.
- Primarily for installation in mechanical gearboxes, e.g. track drives (almost fully integration into a mechanical gearbox, extremely compact unit)
- The output speed depends on the flow capacity of the pump and the displacement of the motor
- The torque increases with the pressure differential between the high and low pressure side and with increasing displacement
- Compact design
- High efficiency
- Complete unit, ready assembled and tested
- Easy assembly, simply „plug-in“ to mechanical gearboxes
- No installation tolerances to consider

Ordering Code / Standard Program

	A2F		E		/	6		W	-	V					
01	02	03	04	05		06	07	08		09	10	11	12	13	14

Hydraulic fluid

01	Mineral oil, HFD for sizes 250...355 only in combination with long-life bearing "L" (no code)														
	HFB-, HFC hydraulic fluid														
	sizes 23...180 (no code) sizes 250...355 (only in combination with long-life bearing "L")														E-

Axial piston unit

02	Bent axis design, fixed displacement														A2F
----	--------------------------------------	--	--	--	--	--	--	--	--	--	--	--	--	--	-----

Drive shaft bearing

03												23...180	250...355	
	Mechanical bearing (no code)											●	●	
Long-life bearing											-	●	L	

Mode of operation

04	Motor, plug-in version														E
----	------------------------	--	--	--	--	--	--	--	--	--	--	--	--	--	---

Size

05	≈ Displacement V_g (cm ³)														
		23	28	32	45	56	63	80	90	107	125	160	180	250	355

Series

06															6
----	--	--	--	--	--	--	--	--	--	--	--	--	--	--	---

Index

07												sizes 23...180	1
												sizes 250...355	0

Direction of rotation

08	Viewed on shaft end											alternating	W
----	---------------------	--	--	--	--	--	--	--	--	--	--	-------------	---

Seals

09	FKM (Flour-Caoutchouc)														V
----	------------------------	--	--	--	--	--	--	--	--	--	--	--	--	--	---

Shaft end

10	Splined shaft DIN 5480	23	28	32	45	56	63	80	90	107	125	160	180	250	355	A
		●	●	●	-	●	●	●	●	●	●	●	●	●	-	-

Mounting flange

11												23...180	250...355	L
	2-hole- similar ISO 3019-2											●	-	M
4-hole- similar ISO 3019-2											-	●		

Ordering Code / Standard Program

	A2F		E		/	6		W	-	V					
01	02	03	04	05		06	07	08		09	10	11	12	13	14

Service line connections ¹⁾			23	28	32	45	56	63	80	90	107	125	160	180	250	355		
12	SAE flange ports A and B rear	01	0	-	-	-	-	-	-	-	-	-	-	-	-	●	●	010
		7	-	-	-	-	-	-	-	-	-	-	-	-	-	-	●	017
	SAE flange ports A and B lateral, opposite	02	0	-	-	-	-	-	-	-	-	-	-	-	-	●	-	020
		7	-	-	-	-	-	-	-	-	-	-	-	-	-	●	-	027
	SAE flange ports A and B bottom (same side)	10	0	●	●	●	●	●	●	●	●	●	●	●	●	-	●	100
	Port plate for fitting a counterbalance valve	18	1	-	●	●	●	●	●	●	●	●	●	●	●	-	-	181
Port plate with integrated pressure relief valves	19	1	-	●	●	●	●	●	●	●	●	●	●	●	-	-	191	
		2	-	●	●	●	●	●	●	●	●	●	●	●	-	-	192	

Valves

without valves	0
with pressure relief valves (without pressure sequence range)	1
with pressure relief valves (with pressure sequence range)	2
with flushing and boost pressure valve ²⁾	7

Speed measurement		23...45	56...180	250	355	
13	without speed measurement (no code)	●	●	●		
	prepared for speed measurement with HDD sensor ³⁾	-	●	-		F

Special design		
14	Standard version (no code)	
	Specific version for slew drive applications (standard for port plate 19)	J

¹⁾ threads of fastening screws are metric

²⁾ sizes 23...180, we kindly ask for consultation

³⁾ complete order recommended (A2FE inc. speed sensor)

● = available - not available

■ = preferred program

Technical Data

Hydraulic fluid

Before starting project planning, please refer to our data sheets RE 90220 (mineral oil), RE 90221 (environmentally acceptable pressure fluids) and RE 90223 (HF pressure fluids) for detailed information regarding the choice of pressure fluids and conditions of use.

The A2FE fixed displacement plug-in motor is not suitable for use with HFA. If HFB, HFC and HFD or environmentally acceptable pressure fluids are being used, the constraints regarding technical data and seals mentioned in RE 90221 and RE 90223 must be observed.

If necessary, please consult us to discuss the type of pressure fluid you intend to use.

Operating viscosity range

We recommend that a viscosity (at operating temperature) for optimum efficiency and service life purposes of

$$v_{\text{opt}} = \text{optimum viscosity } 16 \dots 36 \text{ mm}^2/\text{s}$$

be chosen, taken the circulation temperature (closed circuit) and tank temperature (open circuit) into account.

Limits of viscosity range

The following values apply in extreme cases:

Sizes 23...180:

$$v_{\text{min}} = 5 \text{ mm}^2/\text{s}$$

short term ($t < 3 \text{ min}$) at max. permitted temperature

$$t_{\text{max}} = +115^\circ\text{C}.$$

$$v_{\text{max}} = 1600 \text{ mm}^2/\text{s},$$

short term ($t < 3 \text{ min}$) with cold start ($p < 30 \text{ bar}$, $n \leq 1000 \text{ rpm}$,

$$t_{\text{min}} = -40^\circ\text{C}.$$

Sizes 250...355:

$$v_{\text{min}} = 10 \text{ mm}^2/\text{s},$$

short term ($t < 3 \text{ min}$) at max. permitted temperature

$$t_{\text{max}} = +90^\circ\text{C}$$

$$v_{\text{max}} = 1000 \text{ mm}^2/\text{s},$$

short term ($t < 3 \text{ min}$) with cold start ($p \leq 30 \text{ bar}$, $n \leq 1000 \text{ rpm}$,

$$t_{\text{min}} = -25^\circ\text{C}.$$

Note that the maximum fluid temperature must not be exceeded locally either (e.g. bearing area). The temperature in the bearing area is - depending on pressure and speed - up to 12 K higher than the average waste fluid temperature.

Special measures are necessary at temperatures between -25°C and -40°C . Please consult us.

See RE 90300-03-B for detailed information about use at low temperatures.

Selection diagram

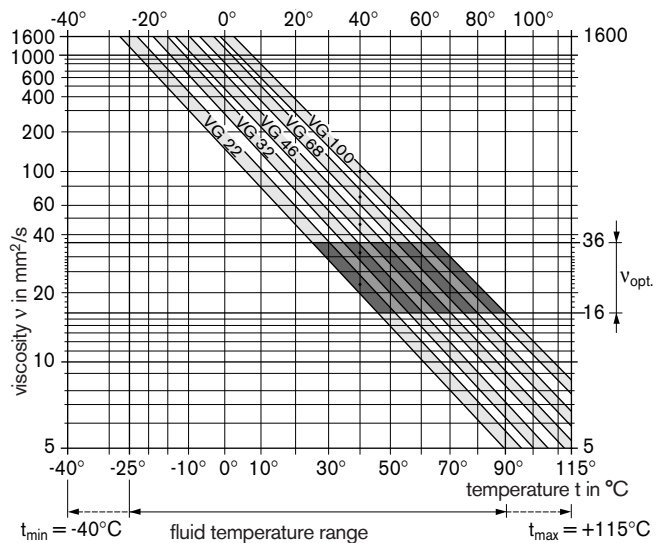

Details regarding the selection of hydraulic fluid

The correct selection of hydraulic fluid requires knowledge of the operating temperature in relation to the ambient temperature: in a closed circuit the circulation temperature, in an open circuit the tank temperature.

The hydraulic fluid should be selected so that within the operating temperature range, the operating viscosity lies within the optimum range (v_{opt}) (see shaded section of the selection diagram). We recommend that the highest possible viscosity range should be chosen in each case.

Example: At an ambient temperature of $X^\circ\text{C}$ an operating temperature of 60°C is set in the circuit. In the optimum operating viscosity range (v_{opt} ; shaded area) this corresponds to the viscosity classes VG 46 or VG 68; to be selected: VG 68.

Please note: The leakage fluid temperature, which is affected by pressure and rotational speed, is always higher than the circulation temperature or tank temperature. At no point in the system may the temperature be higher than 115°C (sizes 23...180) or 90°C (sizes 250...355).

If this cannot be achieved due to unusual operating parameters or high ambient temperatures, we recommend the use of a flushing and boost pressure valve (see page 11).

Filtration

The finer the filtering, the cleaner the fluid and the longer the service life of the axial piston unit.

To ensure proper function of the axial piston unit, the pressure fluid must have a cleanliness level of at least

20/18/15 according to ISO 4406.

At very high pressure fluid temperatures (90°C to max. 115°C , not permitted for sizes 250...355), a cleanliness level of at least

19/17/14 according to ISO 4406 is required.

Please consult us if these cleanliness levels cannot be achieved.

Technical Data

Operational pressure range

Maximum pressure on port A or B
(pressure data according DIN 24312)

Shaft end A	sizes 23...180	
Nominal pressure p_N	400 bar	
Peak pressure p_{max}	450 bar	
Summation pressure (A+ B)	700 bar	

Shaft end Z	sizes 23, 28, 45	size 56
	sizes 80, 107, 160	sizes 250, 355
Nominal pressure p_N	400 bar	350 bar
Peak pressure p_{max}	450 bar	400 bar
Summation pressure (A+ B)	700 bar	700 bar

Please note:

These values are valid for radial force free load. With additional radial force see RE 91001.

In cases of pulsating loading above 315 bar, we recommend the version with splined shaft A (sizes 23...180).

Minimum inlet pressure on service line port A (B)

In order to avoid damage of the motor a minimum inlet pressure at the inlet zone must be assured. The minimum inlet pressure is related to the rotational speed of the fixed motor.

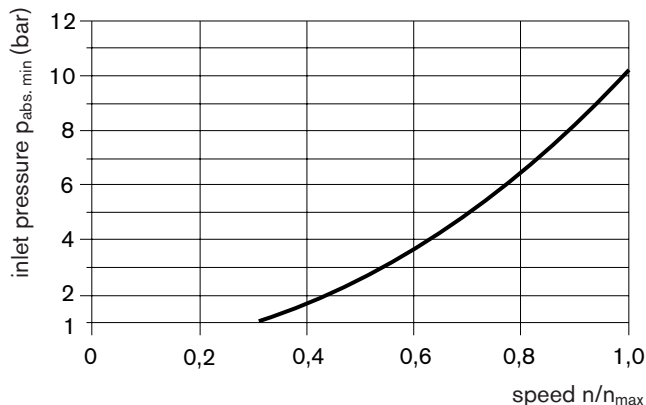

Please consult us if these conditions cannot be satisfied

Direction of flow

Direction of rotation, (viewed on shaft)
clockwise counter-clockwise

A to B B to A

Speed range

No limit to minimum speed n_{min} . If uniform motion is required, n_{min} must not be less than 50 rpm. See table on page 6 for maximum speed.

Long-life-bearing (sizes 250...355)

For long service life and use with HF pressure fluids. Same external dimensions as motor with standard bearing. A long-life bearing can be supplied.

Sealing ring

Permissible pressure load

The service life of the sealing ring is affected by the speed of the motor and the case drain pressure. The permitted loading with intermittent case drain pressure depends on the rotational speed (see chart). Short-term ($t < 5$ s) pressure spikes of up to 6 bar absolute are permitted.

The average continuous case drain pressure must not exceed 3 bar absolute.

The pressure in the housing must be equal to or greater than the external pressure on the shaft seal.

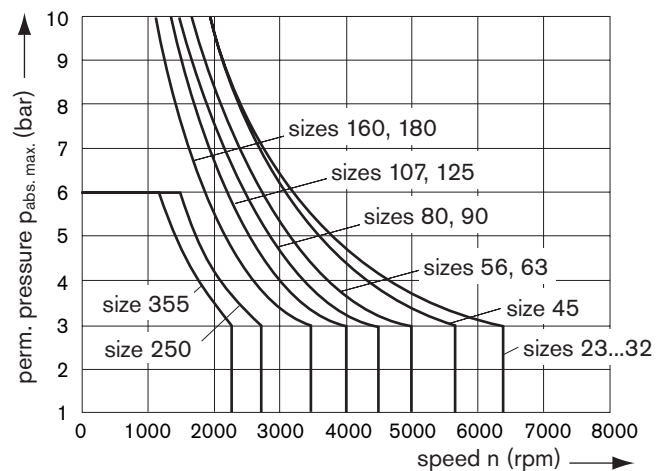

Temperature range

The FKM shaft seal is admissible for a housing temperature range from
-25°C to +115°C at sizes 23...180 and
-25°C to +90°C at sizes 250...355

Note:

For applications below -25 °C a NBR shaft seal is necessary (admissible temperature range -40 °C to +90 °C). Please consult us.

Technical Data

Table of values (theoretical values, ignoring η_{mh} and η_v ; values rounded)

Size			23	28	32	45	56	63	80
Displacement	V_g	cm ³	22,9	28,1	32	45,6	56,1	63	80,4
Speed max.	n_{max}	rpm	6300	6300	6300	5600	5000	5000	4500
	$n_{max\ intermit.}^{1)}$	rpm	6900	6900	6900	6200	5500	5500	5000
Flow max.	$q_{V\ max}$	L/min	144	176	201	255	280	315	360
Torque constants	T_K	Nm/bar	0,36	0,445	0,509	0,725	0,89	1,0	1,27
Torque at $\Delta p = 400\ bar$	T	Nm	144	178	204	290	356	400	508
Rotary stiffness		Nm/°	230	230	230	330	440	440	670
Mass moment of inertia around output shaft	J	kgm ²	0,0012	0,0012	0,0012	0,0024	0,0042	0,0042	0,0072
Case fill capacity		L	0,20	0,20	0,20	0,33	0,45	0,45	0,55
Weight (approx.)	m	kg	10,5	10,5	10,5	15	18	19	23

Size			90	107	125	160	180	250	355
Displacement	V_g	cm ³	90	106,7	125	160,4	180	250	355
Speed max.	n_{max}	rpm	4500	4000	4000	3600	3600	2700	2240
	$n_{max\ intermit.}^{1)}$	rpm	5000	4400	4400	4000	4000	–	–
Flow max.	$q_{V\ max}$	L/min	405	427	500	577	648	675	795
Torque constants	T_K	Nm/bar	1,43	1,70	1,99	2,54	2,86	3,98	5,65
Torque at $\Delta p = 400\ bar$	T	Nm	572	680	796	1016	1144	1393 ²⁾	1978 ²⁾
Rotary stiffness		Nm/°	670	880	880	1350	1350	3733	5092
Mass moment of inertia die around output shaft	J	kgm ²	0,0072	0,0116	0,0116	0,0220	0,0220	0,061	0,102
Case fill capacity		L	0,55	0,8	0,8	1,1	1,1	2,5	3,5
Weight (approx.)	m	kg	25	34	36	47	48	82	110

¹⁾ intermittent maximum speed: overspeed at discharge and over-running travel operations, $t < 5\ sec.$ and $\Delta p < 150\ bar$

²⁾ torque at $\Delta p = 350\ bar$

Ermittlung der Nenngröße

Flow	$q_v = \frac{V_g \cdot n}{1000 \cdot \eta_v}$	L/min	$V_g =$ Displacement per revolution in cm ³
			$\Delta p =$ Differential pressure in bar
			$n =$ Speed in rpm
Output speed	$n = \frac{q_v \cdot 1000 \cdot \eta_v}{V_g}$	rpm	$\eta_v =$ Volumetric efficiency
			$\eta_{mh} =$ Mechanical-hydraulic efficiency
Output torque	$T = \frac{V_g \cdot \Delta p \cdot \eta_{mh}}{20 \cdot \pi}$	Nm	$\eta_t =$ Overall efficiency
Output power	$P = \frac{2 \pi \cdot T \cdot n}{60000} = \frac{q_v \cdot \Delta p \cdot \eta_t}{600}$	kW	

Unit Dimensions, Sizes 23...180

Before finalizing your design, please request approved installation drawing. Dimensions in mm

Port plate 10: SAE ports, bottom

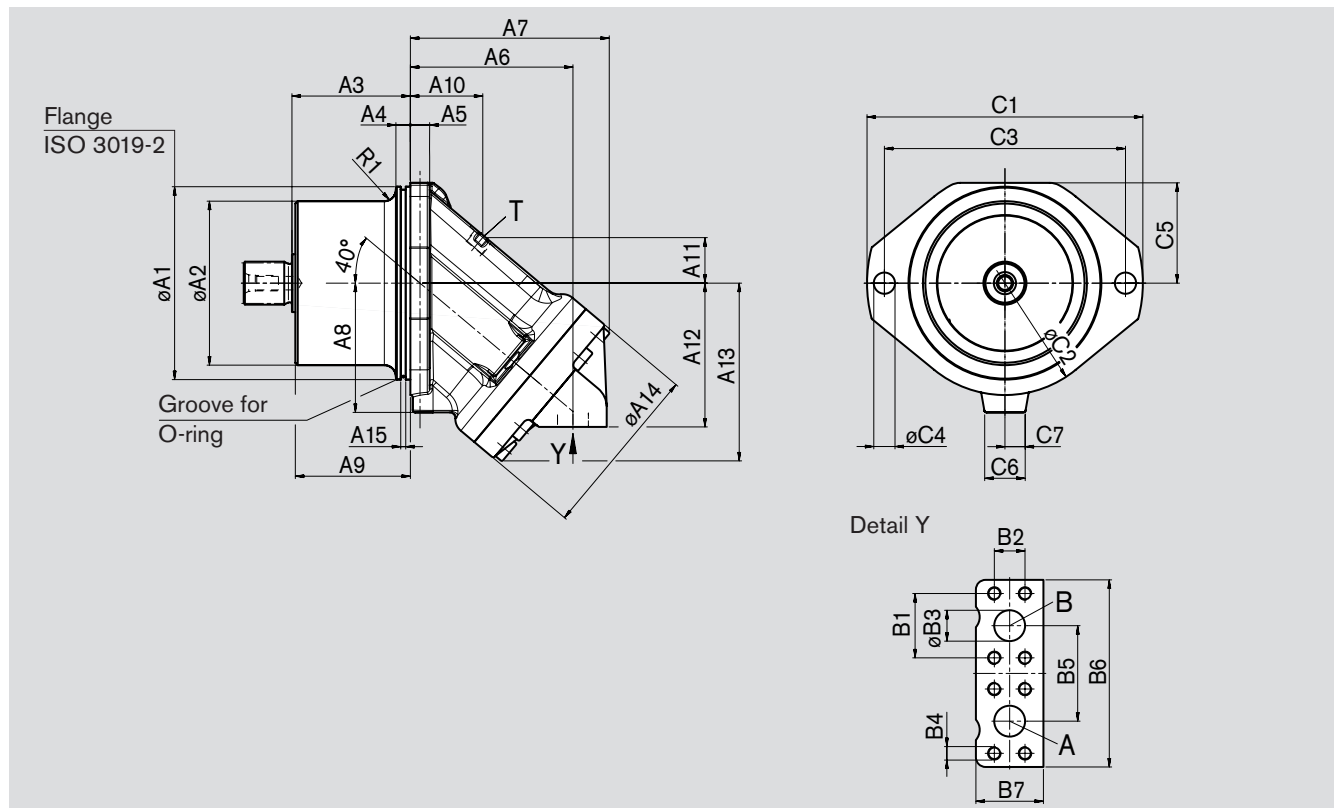

Size	$\phi A1$	$\phi A2$	A3	A4	A5	A6	A7	A8	A9	A10	A11	A12	A13	$\phi A14$	A15
23, 28, 32	135 _{-0,025}	94 _{-0,5}	88,8	15	16	94	114	95	87,1	45	27	91	105	106	5,2
45	160 _{-0,025}	117 ₋₂ ^{+1,5}	92,3	15	18	109	133	106	90	50	31,3	102	119	118	5,2
56, 63	160 _{-0,025}	121 _{-0,5}	92,3	15	18	122	146	109	90	59	34	107	128	128	5,2
80, 90	190 _{-0,029}	140,3 _{-0,5}	110	15	20	127	157	123	106	54	41	120	144	138	5,2
107, 125	200 _{-0,029}	152,3 _{-0,5}	122,8	15	20	143	178	135	119	58	41	136	158	150	5,2
160, 180	200 _{-0,029}	171,6 _{-0,5}	122,8	15	20	169	206	134	119,3	75	47	149	184	180	5,2

Size	R1	O-ring ¹⁾	B1	B2	$\phi B3$	B4 DIN 13 ²⁾	B5	B6	B7	Ports A, B SAE J518	Case drain port T DIN 3852
23, 28, 32	10	126x4	40,5	18,2	13	M8x1,25; 15 deep	59	115	40	1/2 in	M16x1,5; 12 deep 100 Nm ³⁾
45	10	150x4	50,8	23,8	19	M10x1,5; 17 deep	75	147	49	3/4 in	M18x1,5; 12 deep 140 Nm ³⁾
56, 63	10	150x4	50,8	23,8	19	M10x1,5; 17 deep	75	147	48	3/4 in	M18x1,5; 12 deep 140 Nm ³⁾
80, 90	10	180x4	57,2	27,8	25	M12x1,75; 17 deep	84	166	60	1 in	M18x1,5; 12 deep 140 Nm ³⁾
107, 125	16	192x4	66,7	31,8	32	M14x2; 19 deep	99	194	70	1 1/4 in	M18x1,5; 12 deep 140 Nm ³⁾
160, 180	12	192x4	66,7	31,8	32	M14x2; 19 deep	99	194	70	1 1/4 in	M22x1,5; 14 deep 210 Nm ³⁾

Size	C1	$\phi C2$	C3	$\phi C4$	C5	C6	C7
23, 28, 32	188	154	160	14	71	42	13
45	235	190	200	18	82	47,5	15
56, 63	235	190	200	18	82	36	0
80, 90	260	220	224	22	98	40	0
107, 125	286	232	250	22	103	40	0
160, 180	286	232	250	22	104	42	0

¹⁾ not included in the supply

²⁾ tightening torque see general notes

³⁾ tightening torque, max.

Unit Dimensions, Sizes 23...180

Before finalizing your design, please request approved installation drawing. Dimensions in mm

Shaft end

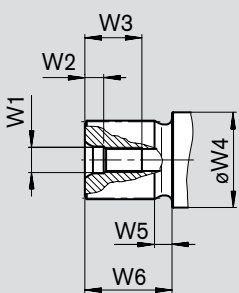

Size	Splined shaft (DIN 5480) ¹⁾	W1 ²⁾	W2	W3	øW4	W5	W6
23, 28, 32	A W30x2x30x14x9g	M10x1,5	7,5	22	35	8	35
23, 28	Z W25x1,25x30x18x9g	M8x1,25	6	19	35	15	43
45	Z W30x2x30x14x9g	M12x1,75	9,5	28	35	8	35
56, 63	A W35x2x30x16x9g	M12x1,75	9,5	28	40	8	40
56	Z W30x2x30x14x9g	M12x1,75	9,5	28	40	8	35
80, 90	A W40x2x30x18x9g	M16x2	12	36	45	8	45
80	Z W35x2x30x16x9g	M12x1,75	9,5	28	45	8	40
107, 125	A W45x2x30x21x9g	M16x2	12	36	50	8	50
107	Z W40x2x30x18x9g	M12x1,75	9,5	28	50	8	45
160, 180	A W50x2x30x24x9g	M16x2	12	36	60	11	55
160	Z W45x2x30x21x9g	M16x2	12	36	60	8	50

¹⁾ $p_N = 400$ bar

²⁾ centering bore according to DIN 332 (thread according to DIN 13), tightening torque see general notes

Unit Dimensions, Size 250

Before finalizing your design, please request approved installation drawing. Dimensions in mm

Port plate 01: SAE ports, rear

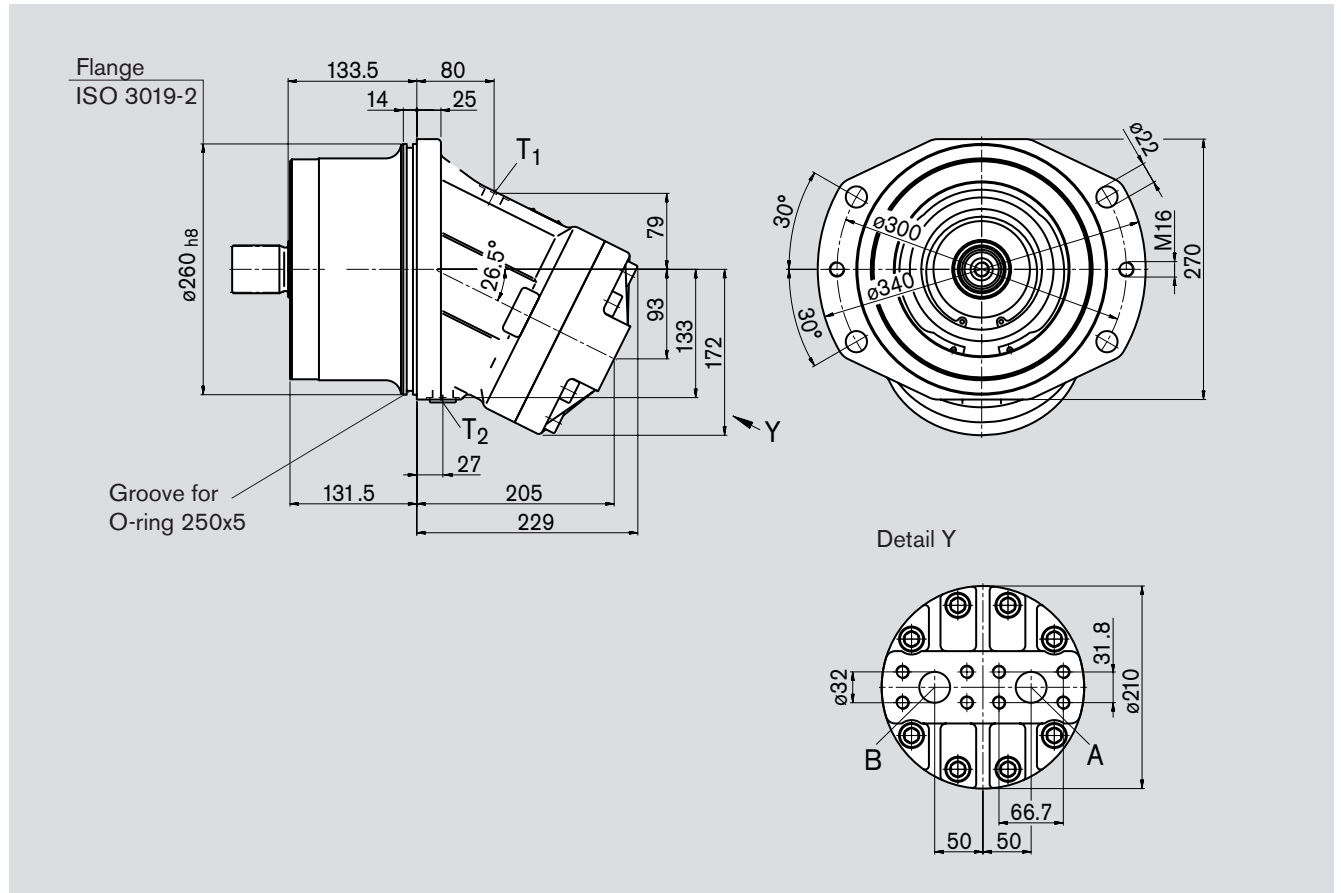

Shaft end

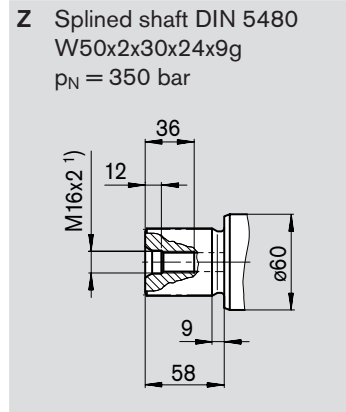

Port plate 02: SAE ports, at side

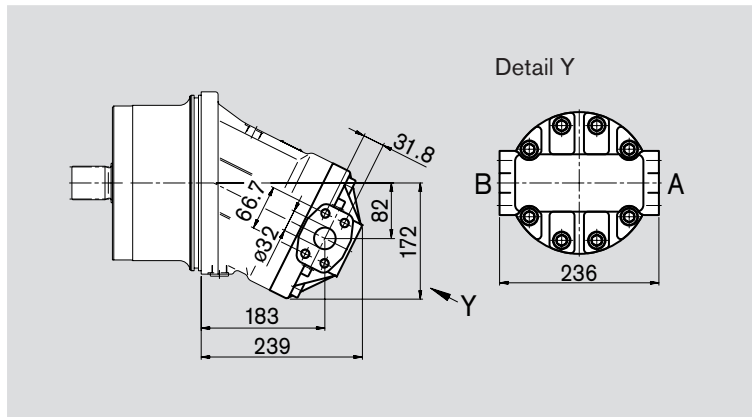

Ports

A, B	Service line ports (high pressure series) Fastening threads	SAE J518 DIN 13	1 1/4 in M14x2; 19 deep ²⁾
T ₁ , T ₂	Case drain ports (T ₂ plugged)	DIN 3852	M22x1,5; 14 deep 210 Nm ³⁾

¹⁾ centering bore according to DIN 332 (thread according to DIN 13), tightening torque see general notes

²⁾ tightening torque see general notes

³⁾ tightening torque, max.

Unit Dimensions, Size 355

Before finalizing your design, please request approved installation drawing. Dimensions in mm

Port plate 10: SAE ports, bottom

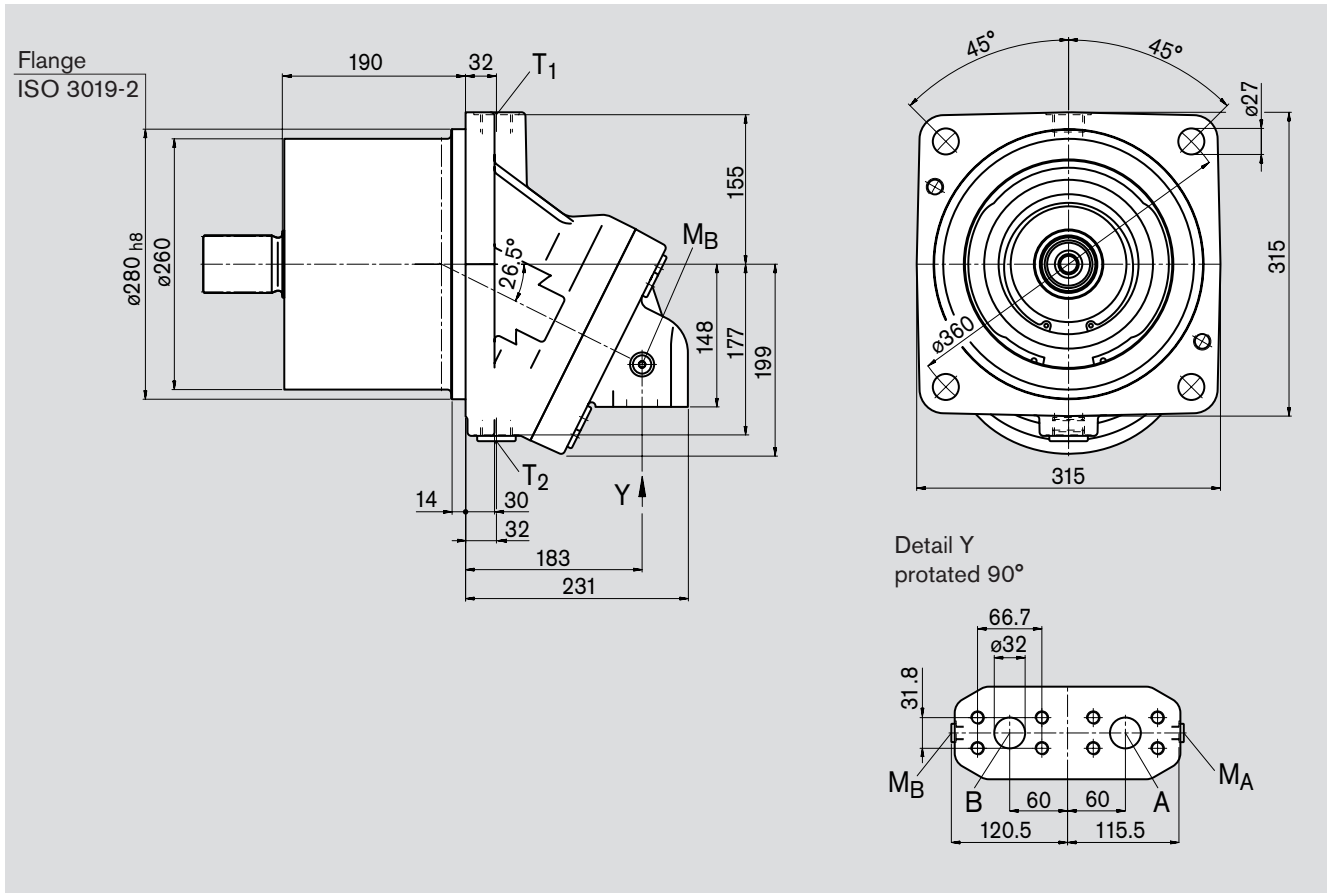

Shaft end

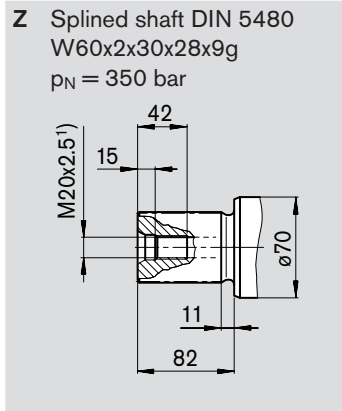

Port plate 01: SAE ports, rear

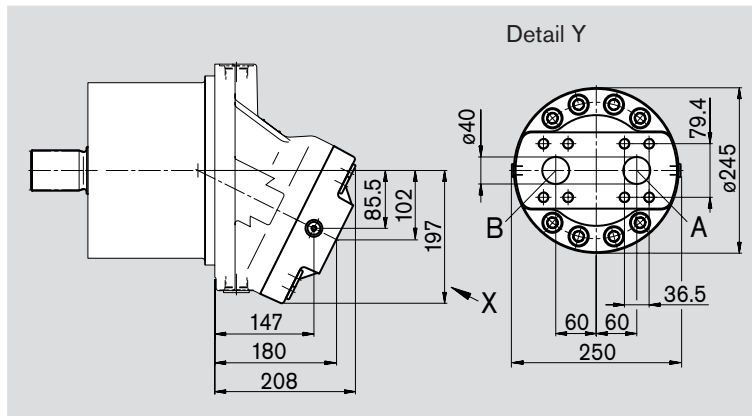

Ports

A, B	Service line ports (high pressure series) Fastening threads	SAE J518 DIN 13	1 1/4 in M14x2; 22 deep ²⁾	
T ₁ , T ₂	Case drain ports (T ₂ plugged)	DIN 3852	M33x2; 18 deep	540 Nm ³⁾
M _A , M _B	Measuring ports operating pressure (plugged)	DIN 3852	M14x1,5; 12 deep	80 Nm ³⁾

¹⁾ centering bore according to DIN 332 (thread according to DIN 13), tightening torque see general notes

²⁾ tightening torque see general notes

³⁾ tightening torque, max.

Flushing and Boost Pressure Valve

Before finalizing your design, please request approved installation drawing. Dimensions in mm

The flushing and boost pressure valve is used to remove heat. In the closed circuit additionally to the case flushing also the minimum boost pressure is assured.

Hydraulic fluid is drained from the relevant low-pressure side into the motor housing. Along with the leakage fluid, it is then discharged into the tank. The hydraulic fluid removed from the circuit must be replaced in the closed circuit with hydraulic fluid by the charge pump.

Opening pressure of charge pressure valve 16 bar (fixed setting). Must be taken into account when setting the charge pressure on the pump in the closed circuit.

On port plate 027, the valve is fitted directly onto the fixed displacement motor (size 250), while on port plate 017 (size 355), it is fitted on a plate.

Orifice can be used to adjust the flow as required.

Standard flow (at low pressure $\Delta p = 25$ bar)

Size	Flushing flow	Orifice-No.
250	10 L/min	on request
355	16 L/min	on request

In the case of non-standard flows, please specify the orifice you require when placing your order.

Circuit diagram

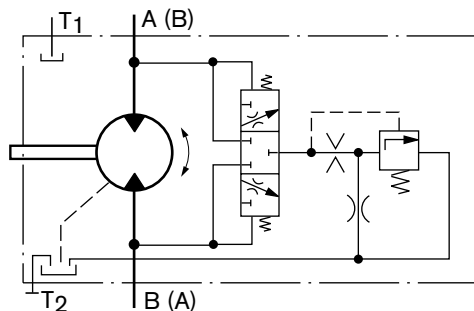

Port plate 027: SAE ports, at side

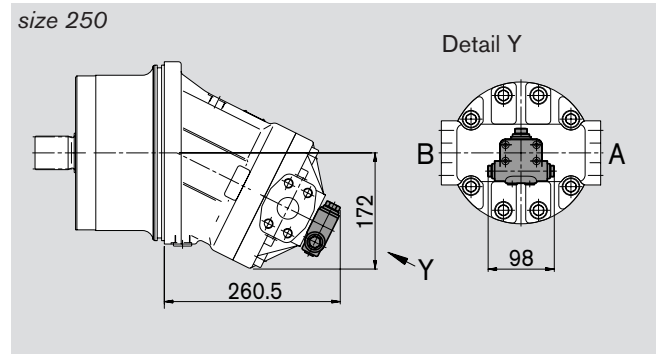

Port plate 017: SAE ports, rear

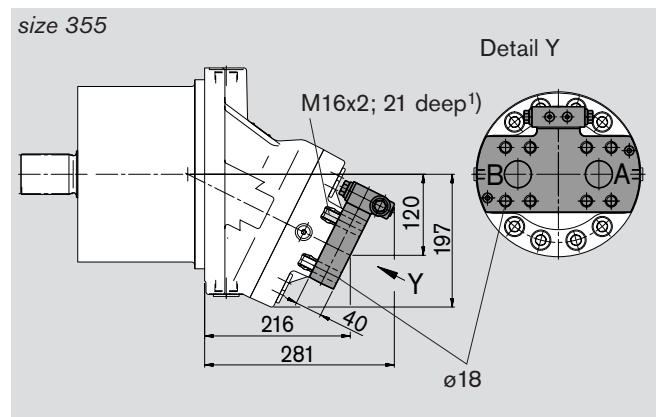

¹⁾ DIN 13, tightening torque see general notes

Pressure Relief Valves

Before finalizing your design, please request approved installation drawing. Dimensions in mm

The pressure relief valves MHDB (as to RE 64642) are protecting the motor against overcharge. When the set opening pressure is reached the hydraulic fluid flows from the high pressure side to the low pressure side.

The pressure relief valves can only be supplied in conjunction with the port plates 181, 191 or 192 (counterbalance valve for fitting on port plate 181, see next page).

Setting range opening pressure _____ 50 – 420 bar

At design "with pressure sequence range" (192) a higher pressure setting can be realized by applying an external pilot pressure of 25 - 30 bar at port p_{St}.

Please indicate in clear text when ordering:

- opening pressure of the pressure relief valve
- opening pressure at pilot pressure applied at p_{St} (for design 192 only)

Design without pressure sequence range "191"

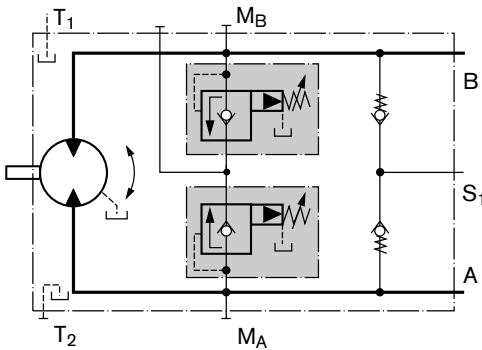

Design with pressure sequence range "192"

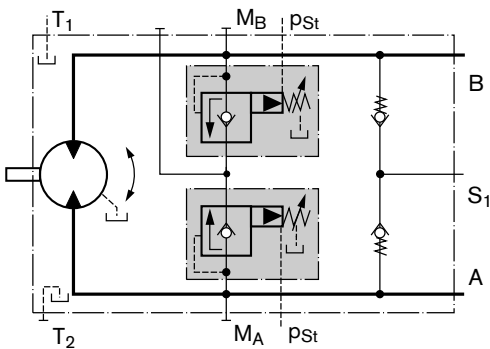

Unit dimensions

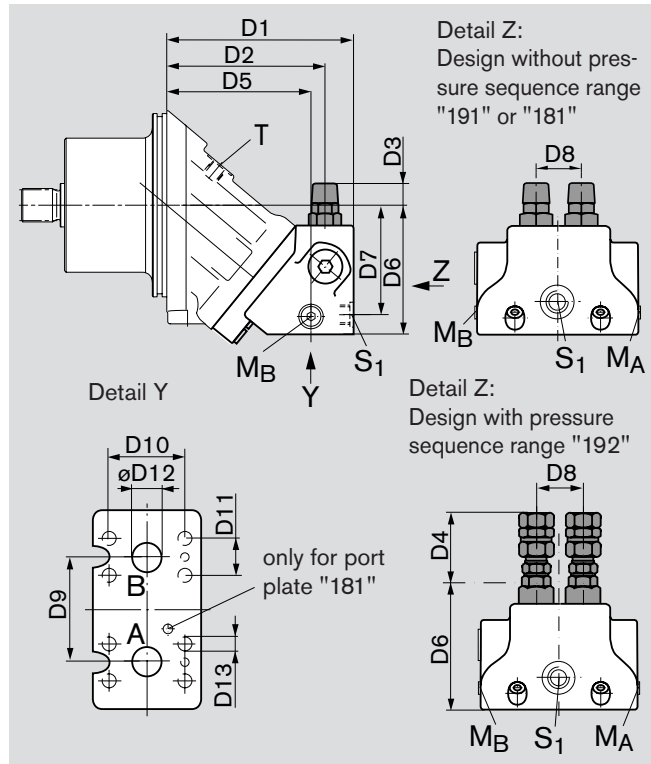

Ports

- A, B Service line ports SAE J518
- S₁ Boosting (only for port plate 191/192)
- M_A, M_B Measuring ports (plugged)
- p_{St} Pilot pressure port (only for port plate 192)

Size	A, B ¹⁾	S ₁ ²⁾	M _A , M _B	p _{St} ³⁾
28, 32	SAE 3/4 in	M22x1,5; 14 deep	M20x1,5; 14 deep ²⁾	G 1/4
45	SAE 3/4 in	M22x1,5; 14 deep	M20x1,5; 14 deep ²⁾	G 1/4
56, 63	SAE 3/4 in	M26x1,5; 16 deep	M26x1,5; 16 deep ²⁾	G 1/4
80, 90	SAE 1 in	M26x1,5; 16 deep	M26x1,5; 16 deep ²⁾	G 1/4
107, 125	SAE 1 1/4 in	M26x1,5; 16 deep	M26x1,5; 16 deep ²⁾	G 1/4
160, 180	SAE 1 1/4 in	M26x1,5; 16 deep	M30x1,5; 16 deep	G 1/4

1) SAE J518 2) DIN 3852 3) DIN ISO 228

Size		D1	D2	D3	D4	D5	D6	D7	D8	D9	D10	D11	øD12	D13 ⁴⁾
28, 32	MHDB.16	145	122	25	63	110	102	87	36	66	50,8	23,8	19	M10; 17 deep
45	MHDB.16	161	137	22	60	126	113	98	36	66	50,8	23,8	19	M10; 17 deep
56, 63	MHDB.22	189	162	19	57	147	124	105	42	75	50,8	23,8	19	M10; 13 deep
80, 90	MHDB.22	193	165	17,5	55	151	134	114	42	75	57,2	27,8	25	M12; 18 deep
107, 125	MHDB.32	216	184	10	48	168	149,5	130	53	84	66,7	31,8	32	M14; 19 deep
160, 180	MHDB.32	249	218	5	43	202	170	149	53	84	66,7	31,8	32	M14; 19 deep

⁴⁾ DIN 13, tightening torque see general notes

Assembly instructions for port plate with pressure sequence range "192":
When fitting the hydraulic line on the p_{St} port, the lock nut must be held in place!

Counterbalance Valve BVD

Before finalizing your design, please request approved installation drawing. Dimensions in mm

Function

Track/winch counterbalance valves prevent the motor from over-speeding (i.e. -out of control) during overrunning load conditions, which causes motor cavitation in open circuit systems. This overrunning load-induced cavitation occurs in axial piston motors when the motor speed exceeds the speed that would be reached with the available oil flow.

Please note

- BVD counterbalance valve must be specified explicitly in the order. We recommend ordering the counterbalance valve and the motor as a set.
Ordering example: A2FE80/61W-VAL181 + BVD20W27S/41B-V03K00D0800S00
- The counterbalance valve does not replace the mechanical service brake and parking brake.
- Note the detailed information about the BVD counterbalance valve contained in RE 95522!

Application example for winch counterbalance valve BVD..W

- Winch drives in cranes
- Track drives in crawler excavator

Circuit diagram BVD..W

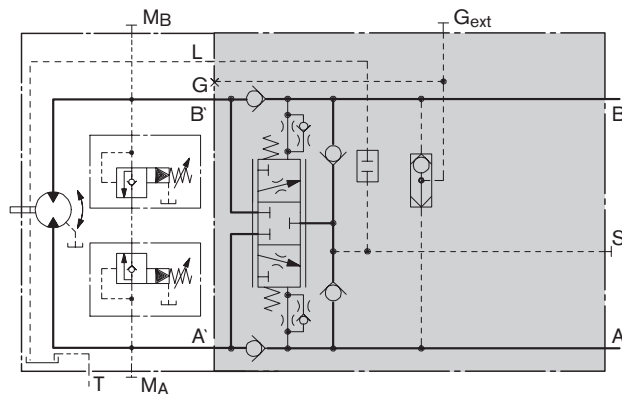

Unit dimensions

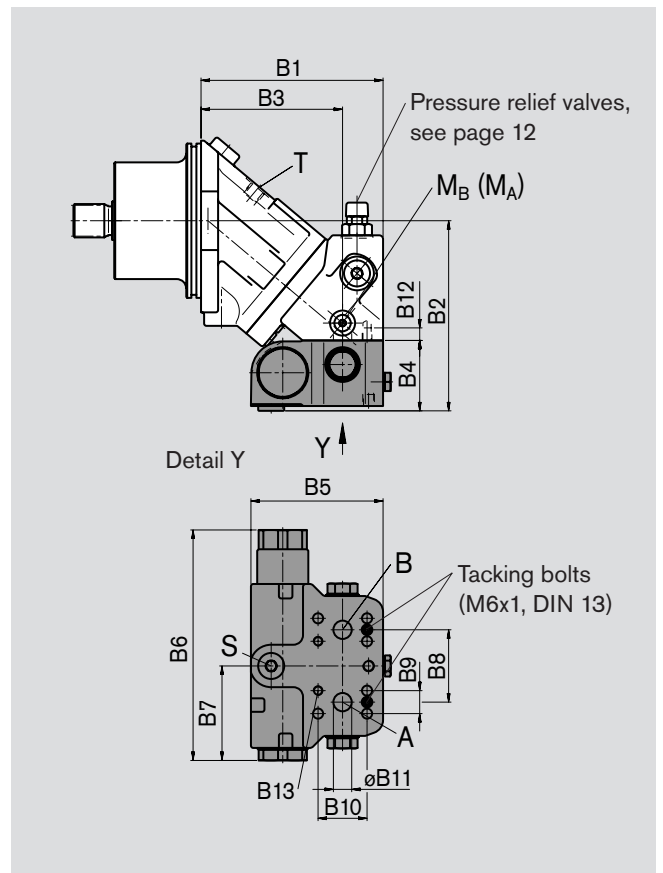

Ports

- A, B Service line ports SAE J518
- S Boosting (plugged)
- MA, MB Measuring ports (plugged)

A2FE	Counterbalance valve			
Size	Type	A, B ¹⁾	S ²⁾	MA, MB ²⁾
28, 32	BVD20..16	SAE 3/4 in	M 22x1,5	M12x1,5
45	BVD20..16	SAE 3/4 in	M 22x1,5	M12x1,5
56, 63	BVD20..17	SAE 3/4 in	M 22x1,5	M12x1,5
80, 90	BVD20..27	SAE 1 in	M 22x1,5	M12x1,5
107, 125	BVD25..38	SAE 1 1/4 in	M 27x2	M12x1,5
160, 180	BVD25..38	SAE 1 1/4 in	M 27x2	M12x1,5
250	on request			

Size	B1	B2	B3	B4	B5	B6	B7	B8	B9	B10	øB11	B12 ³⁾	B13 ³⁾
28, 32 BVD20..16	145	180	110	83 ⁴⁾	137	239	98	66	23,8	50,8	19	M10; 17 deep	M10; 14 deep
45 BVD20..16	161	191	126	83 ⁴⁾	137	239	98	66	23,8	50,8	19	M10; 17 deep	M10; 14 deep
56, 63 BVD20..17	189	192	147	73	137	239	98	75	23,8	50,8	19	M10; 17 deep	M10; 14 deep
80, 90 BVD20..27	193	202	151	73	137	239	98	75	27,8	57,2	25	M12; 18 deep	M12; 16 deep
107, 125 BVD25..38	216	238	168	90	151,5	292	120,5	84	31,8	66,7	32	M14; 19 deep	M14; 19 deep
160, 180 BVD25..38	249	255	202	90	151,5	292	120,5	84	31,8	66,7	32	M14; 19 deep	M14; 19 deep

1) SAE J518

2) DIN 3852

3) DIN 13, tightening torque see general notes

4) with adapting plate

Speed Measurement

Before finalizing your design, please request approved installation drawing. Dimensions in mm

Version „F“ (sizes 23-180): with HDD sensor

The A2FE...F ("prepared for speed measurement") versions have teeth on the drive shaft. A sensor installed in the motor counts the teeth on the rotating shaft, and generates a signal in proportion to the speed.

The Version F is suitable to be build-on to HDD hall effect speed sensor (see RE 95135). The HDD sensor is flange mounted with two locking screws at the especially planed port. The standard connection is plugged with a compression-proof flange cover.

We recommend ordering the A2FE fixed displacement motor with fitted sensor. The ordering code for the sensor must be specified separately.

Unit dimensions

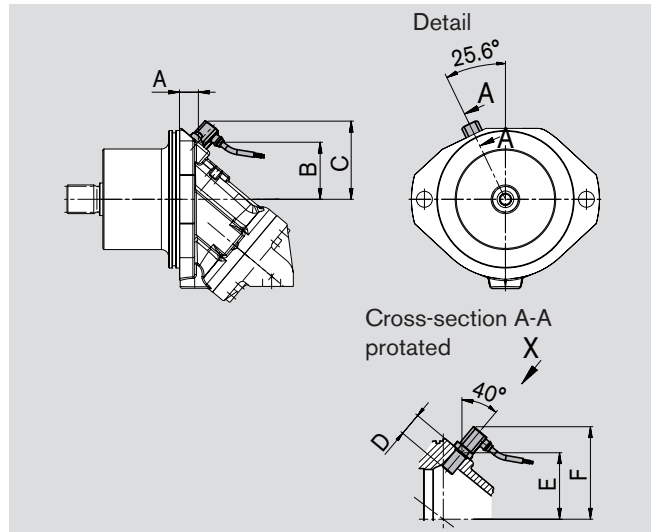

Detail X

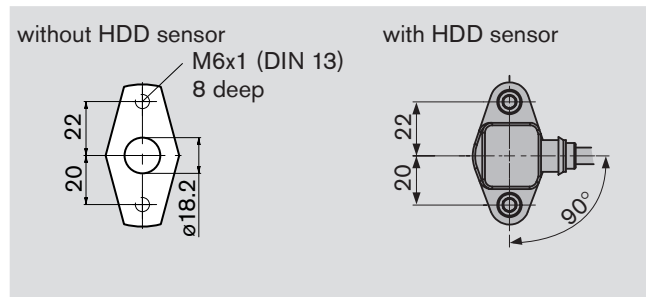

Size	56, 63	80, 90	107, 125	160, 180
Number of teeth	47	53	59	67
A	26,2	19	19	29
B	67,1	71,6	76,1	82,9
C	103,7	108,2	112,7	119,4
D	32	32	32	32
E	74,4 ±0,1	79,4 ±0,1	84,4 ±0,1	91,9 ±0,1
F	109,4	115,4	120,4	127,9

Suitable speed sensor: sizes 56-180: HDD.L32../20 (see RE 95135)

Installation and Commissioning Notes

General

The motor case must be completely filled with hydraulic fluid during commissioning and during operation (filling the case chamber).

The motor must be started at low speed and no load until the system has been bled completely.

If stopped for an extended period, fluid may drain out of the case through the service lines. When restarting, make sure that the case contains sufficient fluid.

The leakage fluid inside the case chamber must be drained off to the tank through the highest case drain port.

Installation position

Shaft horizontal or shaft downwards.

Installation below the tank

Motors below min. oil level in the tank (standard)

- Fill axial piston motor before startup via the highest case drain port
- Run the motor at low speed until the system is filled completely (bleed through service line port A, B if tubing is long)
- Minimum immersion depth of leakage line in tank: 200 mm (relative to the min. oil level in the tank)

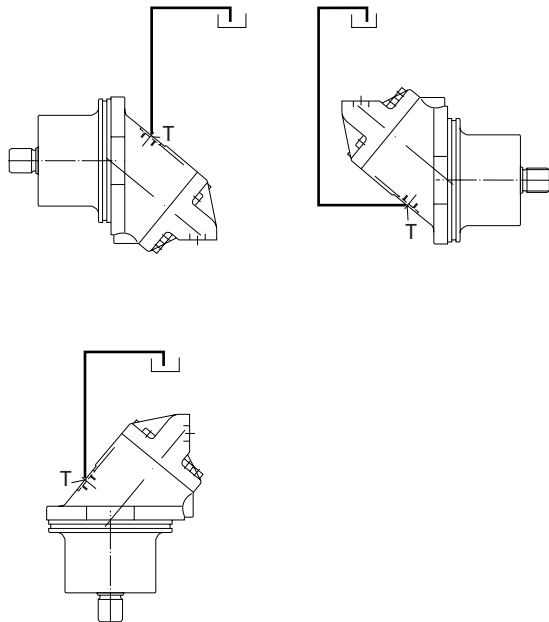

Installation above the tank

Motor above minimum oil level in tank

- Proceed in same way as below the tank installation
- Additional measures for installation position 1:
If stopped for an extended period, fluid may drain out of the case chamber through the service lines (air enters through the shaft seal). The bearings will therefore not be properly lubricated when the motor is started up again. Fill the fixed displacement motor before restarting via the highest case drain port.
- Installation position shaft horizontal:
Service line ports upwards are not permitted in case of installation position above the tank.

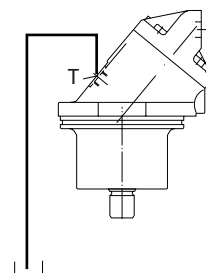
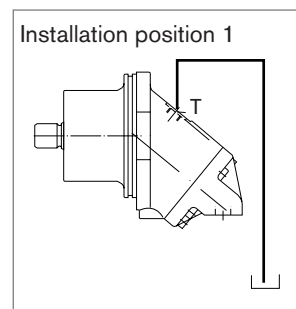

General Notes

- The A2FE motor is designed to be used in open and closed circuits.
- Project planning, assembly, and startup of the motor require the involvement of trained personnel.
- The working and functional ports are only designed to accommodate hydraulic piping.
- Tightening torques: The tightening torques specified in this data sheet are maximum values and may not be exceeded (maximum value for screw thread). Manufacturer specifications for the max. permissible tightening torques of the used fittings must be observed!
For DIN 13 fastening screws we recommend checking the tightening torque individually according to VDI 2230 Edition 2003.
- The housing temperature rises during and shortly after operation. Take suitable safety precautions (e.g. wear protective clothing).
- The data and information contained herein must be adhered to.