

# SOUNDERS 108/114 DB(A) DS 5 / DS 10

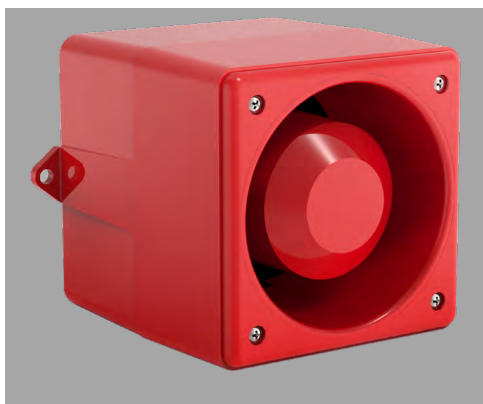

The sounders from the DS 10 / DS 5 series can be used for tough demands under industrial conditions and as universal alarms. The sounders, which are suitable for use both indoors and outdoors, generate warning signals in 31 different tones can be selected with the aid of an internal switch. Optionally, a maximum of 3 additional tones can be switched to by means of an external controller. In addition to the factory settings, the tone combination can be individually selected by means of on-site programming (tone 32).

Custom versions are available for special applications. The GL version is especially resistant to shock and vibration.

- Volume control (DS 5).



protection system



operating temperature



acoustic penetration



warranty



## PRODUCT DS 5

DATA	195-253 V	95-127 V	19-29 V	10-15 V	19-29 V	41-53 V
Operating range	AC 50   60 Hz			DC		
Nominal current consumption	30 mA	60 mA	280 mA	280 mA	280 mA	280 mA

## PRODUCT DS 10

DATA	195-253 V	95-127 V	19-29 V	10-15 V	19-29 V	41-53 V
Operating range	AC 50   60 Hz			DC		
Nominal current consumption	60 mA	120 mA	420 mA	30 mA	420 mA	420 mA

## PRODUCT DS 5 DS 10

DATA	DS 5	DS 10
Sound pressure level	108 dB(A)	114 dB(A)
Sound pressure level @DIN-tone	107 dB(A)	112 dB(A)
Sound level reduction	-20 dB via potentiometer (optional)	
Alarm tones	32 / 4 tones are externally selectable	
Operating temperature	-40 °C ... +55 °C	
Storage temperature	-40 °C ... +70 °C	
Relative humidity	90 %	
Protection system according to EN 6052	IP 66   IP 67	
Material	die-cast aluminium GD-Al Si12 Cu	
Surface coating	epoxy resin paint RAL 3000, flame red	
Cable bushing	2x M20 (1x chrome-plated brass cable fitting, 1x chrome-plated brass blanking plug)	
Clamping range of the cable fitting	8-12 mm	
Connecting terminals	max. 2.5 mm <sup>2</sup>	
Weight	AC: 2.15 kg   DC: 1.95 kg	

## OPTIONS/ACCESSORIES



LSR: volume control



TAS: External tone selection (2 variants) for controlling several tones over great distances:  
1. for all voltages = potential-free NO function  
2. for 12 V / 24 V = voltage input



**DIMENSIONS**

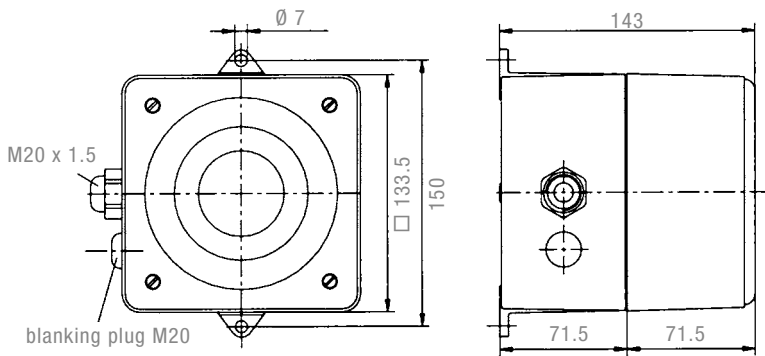

**TONE TABLE**

NO.	DESCRIPTION – BASIC TONE (PRESET: TONE 2)	STAGE			NO.	DESCRIPTION – BASIC TONE (PRESET: TONE 2)	STAGE		
		2	3	4			2	3	4
0	no tone		2	88	57				
2 <sup>1</sup>	Sawtooth, DIN tone 33404-3 Germany (emergency signal), PFEER PTAP	1200 Hz 500 Hz		128	112	57			
15	Slow whoop, NEN 2575 evacuation alarm Netherlands	1200 Hz 500 Hz		131	54	112			
23	Siren	2400 Hz 500 Hz		24	60	112			
24	Siren	1200 Hz 300 Hz		55	23	131			
26	Pulsating tone, industrial alarm Germany	1000 Hz 150 Hz		2	100	93			
31	Sweeping, France NFC48-265	1600 Hz 1400 Hz		128	54	57			
32	Selection of available tone combinations in stages 2, 3 and 4								
36	Sweeping	1500 Hz 700 Hz		146	67	57			
45	Sweeping	1200 Hz 500 Hz		2	57	93			
54	Continuous tone, Finland (all-clear signal)	1500 Hz		2	57	67			
55	Continuous tone, PFEER gas alarm	1200 Hz		2	88	128			
57	Continuous tone, UK BS5839-1	950 Hz		2	128	88			
60	Continuous tone	825 Hz		24	93	125			
63	Continuous tone	725 Hz		2	97	93			
67	Continuous tone, Germany KTA3901 (all-clear signal)	500 Hz		24	93	125			
88	Interrupted tone	950 Hz		2	57	128			
90	Interrupted tone	825 Hz		2	127	108			
92	Interrupted tone	800 Hz		131	146	57			
93	Interrupted tone (fast), horn	800 Hz		2	128	57			
97	Interrupted tone	725 Hz		2	63	93			
98	Interrupted tone, Sweden SS031711 (emergency signal)	700 Hz		112	128	57			
100	Interrupted tone, industrial alarm Germany	680 Hz		2	57	125			
108	Interrupted tone	500 Hz		2	127	60			
112	Interrupted tone, ISO8201 (emergency evacuation signal)	950 Hz		2	57	128			
116	Interrupted tone, IMO (leave ship)	950 Hz		117	93	125			
117	Interrupted tone, IMO SOLAS III/50 + SOLAS III/6.4 (general alarm)	825 Hz		93	116	125			
125	Alternating tone	1400 Hz 1200 Hz		57	93	24			
127	Alternating tone	1075 Hz 825 Hz		2	90	60			
128	Alternating tone	1025 Hz 825 Hz		2	112	57			
131	Alternating tone, UK BS5839-1 (fire alarm, railway crossing)	1000 Hz 800 Hz		24	55	23			
142	Alternating tone	900 Hz 500 Hz		2	54	88			
146	Alternating tone, France NFS 32-001 (fire alarm)	554 Hz 440 Hz		128	67	57			

<sup>1</sup> factory setting

ARTICLE NO.	DS 5			DS 10		
	230 V AC	115 V AC	24 V DC	230 V AC	115 V AC	24 V DC
Standard	23106100000	23106150000	23106800000	23111100000	23111150000	23111800000
DNV	23106100001	23106150001	23106800001	23111100001	23111150001	23111800001
LSR	23106100151	23106150151	23106800151			
TAS	23106100152	23106150152	23106800152	23111100152	23111150152	23111800152

Article numbers for other voltages and versions on request.

## CONNECTION DIAGRAM

DS 5 | DS 10 – AC

DS 5 | DS 10 – DC

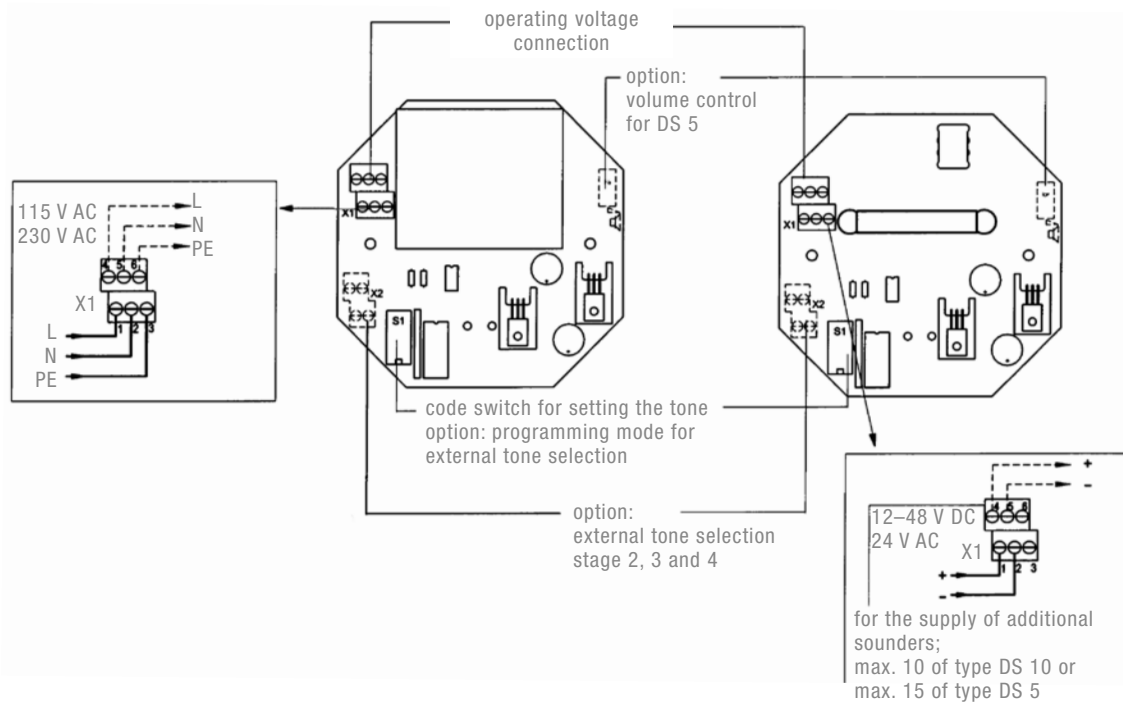

## CONFORMITY TO STANDARDS

DIN EN 54-3: 2001 + DIN EN 54-3/A1: 2001 EN 50 130-4: 1996	Fire alarm systems – part 3: fire alarm devices; Audible signaling devices and annex A1 Stability of system components for fire and burglar alarm systems	DIN EN ISO 7731	Ergonomic – alarms for public areas and workplaces – acoustic alarms
EN 61 000-6-2 EN 61 000-6-3	EMC, stability for industrial areas EMC, emission standard for residential commercial, and light-industrial environments	DIN 33 404/3: 1982	Alarms for workplaces, unified emergency signal
EN 60 947-1: 2003 EN 60 529: 2000	Low voltage switchgear standard Protection system by enclosure (IP code)	ISO 8201: 1987 DIN EN 981: 1997	Evacuation alarm System of acoustic and visual alarm signals and information signals
		ISO 11 429: 1996	System of acoustic and visual alarm signals and information signals