







AISI316L 3/4"-1"NPT volume booster – VB serie

Amplificatore di flusso da 3/4" -1"NPT in AISI316L – serie VB

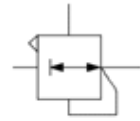
- Suitable for automation equipment to onshore, offshore, pharmaceutical, medical and food applications
- Full material traceability
- Excellent stability and repeatability
- Accurate adjustment and high flow capacity
- Integral by-pass valve
- ATEX 2014/34/UE  II 2G Ex h IIC T6/T5 Gb X
II 2D Ex h IIIC T85°C/T100°C Db X
- &  approved / IP66/ SIL 3 - IEC 61508 



- Adatto per automazione in applicazioni marine, petrolchimiche, farmaceutiche, medicali e alimentari
- Completa rintracciabilità dei materiali
- Eccellente stabilità e ripetibilità
- Precise regolazioni ed elevate portate
- Valvola di by-pass integrale
- ATEX 2014/34/UE  II 2G Ex h IIC T6/T5 Gb X
II 2D Ex h IIIC T85°C/T100°C Db X
- Approvato  ed  / IP66/ SIL 3 - IEC 61508 

Media / Fluido	Compressed air, inert gases, sweet and sour gases
Port thread / Connessioni	3/4" -1" NPT
Signal Connection Connessione segnale	1/4"NPT
Max supply pressure Pressione massima di ingresso	10bar
Max signal/output pressure Pressione massima segnale/uscita	10bar
Flow rate (Cv)/Portata	3/4" - Input = 5.60; Exhaust = 6.50 1" - Input = 8; Exhaust = 8
Working temperature / Temperatura di esercizio	-20°C up to 80°C (NBR); -25°C up to 90°C (FKM); -40°C up to 80°C (EPDM); -60° up tp 90°C (FVMQ)*
Linearity/Linearità	+/- 1.00 FS
In/Output pressure ratio Rapporto di pressione In/Out	1:1

Air supply must be dry enough to avoid ice formation at temperatures below +2°C (+35°F).

*Special version in HNBR (WT -60°C + 90°C)

It provides excellent regulation with high flow for a wide range of applications. Rugged and corrosion-resistant – made in SS316L - Compact small package size – light weight

Permette una regolazione accurata con grandi portate per una vasta gamma di applicazioni. Robusto e resistente alla corrosione – Costruito completamente in AISI316L - Dimensioni di ingombro ridotte – Leggero

BUILDING MATERIALS	Materiali costruttivi
Body, spacer, top AISI316/316L stainless steel	Corpo, distanziale, coperchio in acciaio inossidabile AISI316/316L
Internals, bracket, lock and panel nuts, fixing screws in stainless steel	Vite di regolazione, staffa, dadi di bloccaggio e pannello, viti di fissaggio in acciaio inossidabile
Diaphragm & seals in elastomer	Diaframma e guarnizioni in elastomero

www.sitecna.eu

Overall dimension

Dimensioni di ingombro

Free exhaust port

Scarico libero

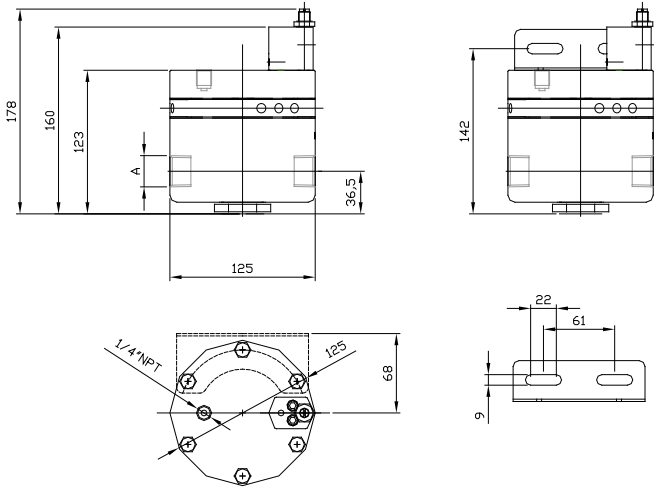

Threaded exhaust port

Scarico convogliato

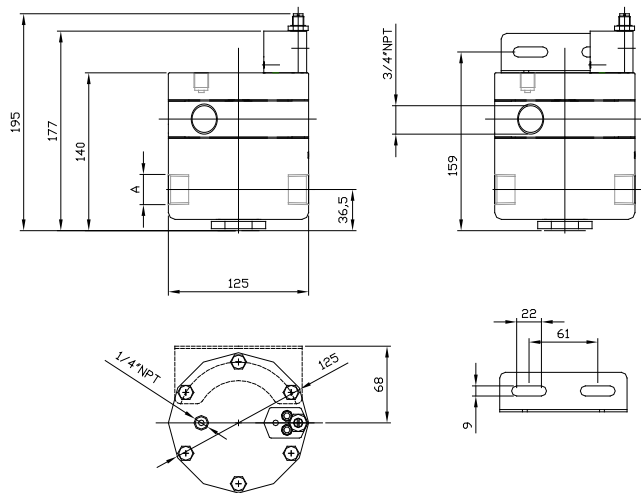

VB12 A=3/4"

VB16 A=1"

Accessories and repair kit

Accessori e ricambi

Maintenance kit / Kit manutenzione	Items K-VB16-* -SS-**
Bracket/Staffa	C0740-40

* Refers to exhaust port: 00= free exhaust; 88 = threaded exhaust

** Refers to seals type: FK→FKM NB→NBR LT→EPDM FL→FVMQ HN→HNBR

Ordering information

Come ordinare

www.sitecna.eu

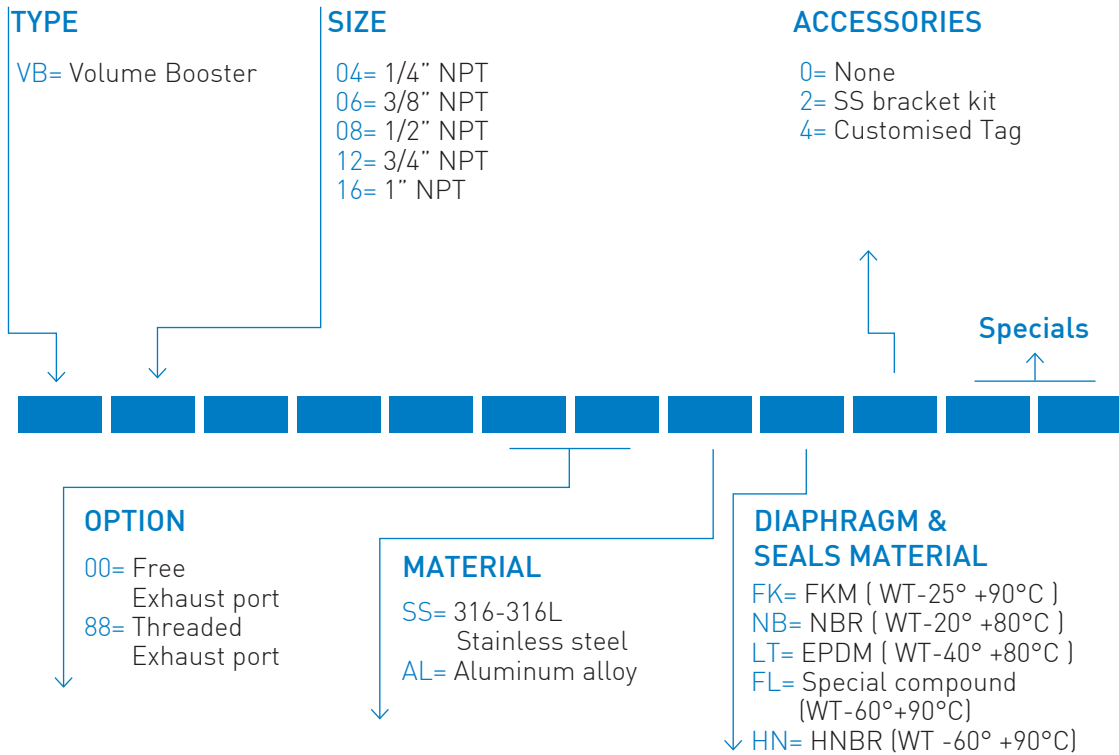

CODE EXAMPLES



VB 04 0 0 00 0 0 SS FK 0

1/4"NPT, SS316L, Volume booster, with FKM diaphragm & seals, Cv In - 2.20 exhaust- 2.40, WT -25°C to 90°C

Amplificatore di flusso da 1/4"NPT in AISI316L con diaframma e tenute in FKM, Cv In - 2.20 exhaust- 2.40, temperatura di lavoro da -25°C a +90°C



VB 08 0 0 00 8 8 AL LT 0

1/2"NPT, Epoxy painted aluminium alloy + SS304 or 316L, volume booster with FKM diaphragm & seals, threaded exhaust, Cv In/exhaust 2.80, WT -25°C to +90°C

Amplificatore di flusso da 1/2"NPT in Lega di alluminio con verniciatura epossidica + AISI304-316L con diaframma e tenute in EPDM, Cv In/Exhaust 2.80, scarico filettato, temperatura di lavoro da -40°C a +80°C