

Plate Microfine single-acting flow control valves

FT 281/5

Single-acting flow control valves available in sizes 03 and 60, max. working pressure 250 Bar, adjustable oil flow rate from 0,1 to 4 Lt./min.

Plate mounted valves

Single-acting control

Carbon steel

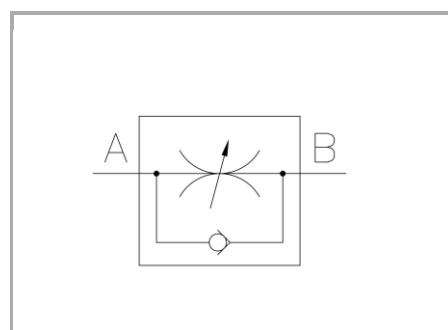

Technical information

Technical description

They are the most suitable solution for those applications requiring precise adjustment characteristics or for low flow rate. They are characterised by a great flow rate section in the direction of free flow. They are provided with plate connections mod. CETOP 03 or interchangeable with the widely used valves (kind 60). The connection O-rings are equipped in series. Max. working pressure 250 bar.

Materials

CORPO BASETTA / CETOP BODY	Acciaio/Steel 11 S Mn Pb 37-UNI EN 10087
CORPO CARTUCCIA / CARTRIDGE BODY	Acciaio/Steel 11 S Mn Pb 37-UNI EN 10087
SPILO DI REGOLAZIONE / ADJUSTING NEEDLE	Acciaio legato/Alloy Steel
GUARNIZIONI / GASKETS	Di serie NBR - A richiesta FPM/Standard NBR-on demand FPM
ANELLI ANTIESTRUSIONE / ANTIEXTRUSION RINGS	PTFE
MANOPOLA TIPO MA / KNOB TYPE MA	Alluminio/Aluminum GD AlSi12- UNI EN AB 46100
MANOPOLA TIPO MP / KNOB TYPE MP	ABS

Technical data

TIPO / TYPE	PRESSIONE ESERCIZIO BAR / WORKING PRESSURE BAR	TEMPERATURA ESERCIZIO / WORKING TEMPERATURE	GRADO DI FILTRAZIONE µm / FILTRATION GRADE µm
03	250	-20°C/+100°C	25
60	250	-20°C/+100°C	25



Dimensional tables and drawings

TIPO / TYPE	A	B	C	D	E	ØF	G	H	L	M
03	38	45	55,5	72	80	22	9,25	40,5	31,75	31
60	39	45	58	73	81	22	12	40,5	31,75	31

TIPO / TYPE	N	P	ØQ	ØR	S	T	OR	VITI / SCREWS	PESO / WEIGHT KG
03	12,7	30,2	5	12	15,5	0,75	108	M5x45	0,710
60	10	33	5	17,2	15,5	0,75	2056	M5x45	0,752

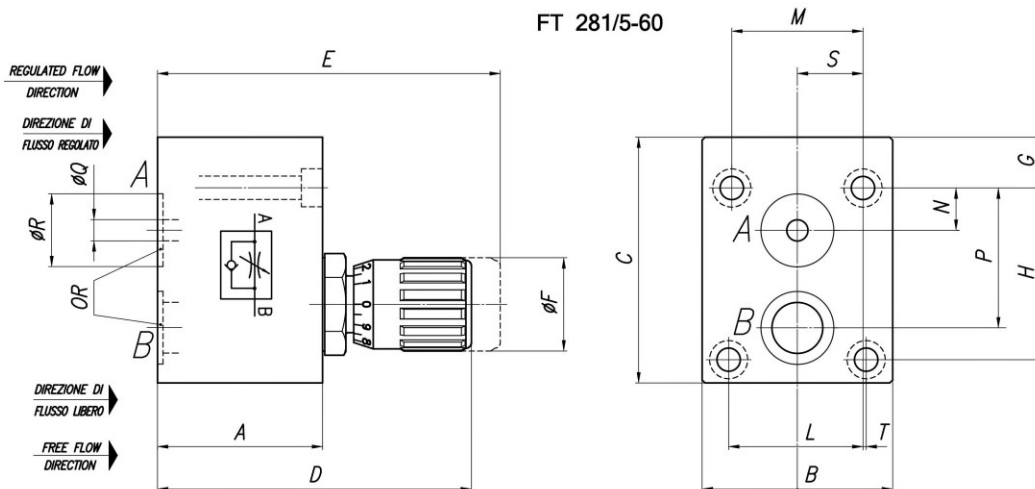
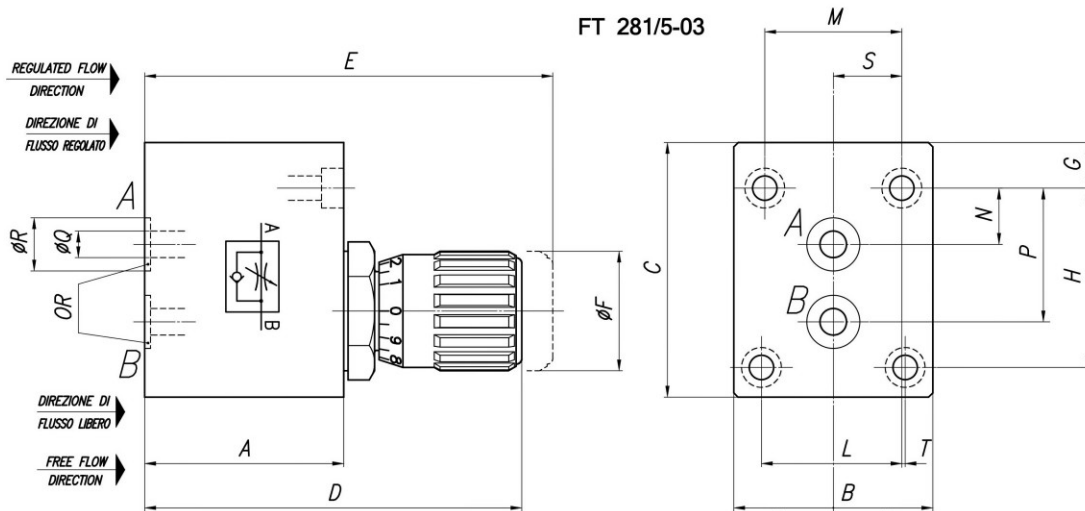



Flow rate curves

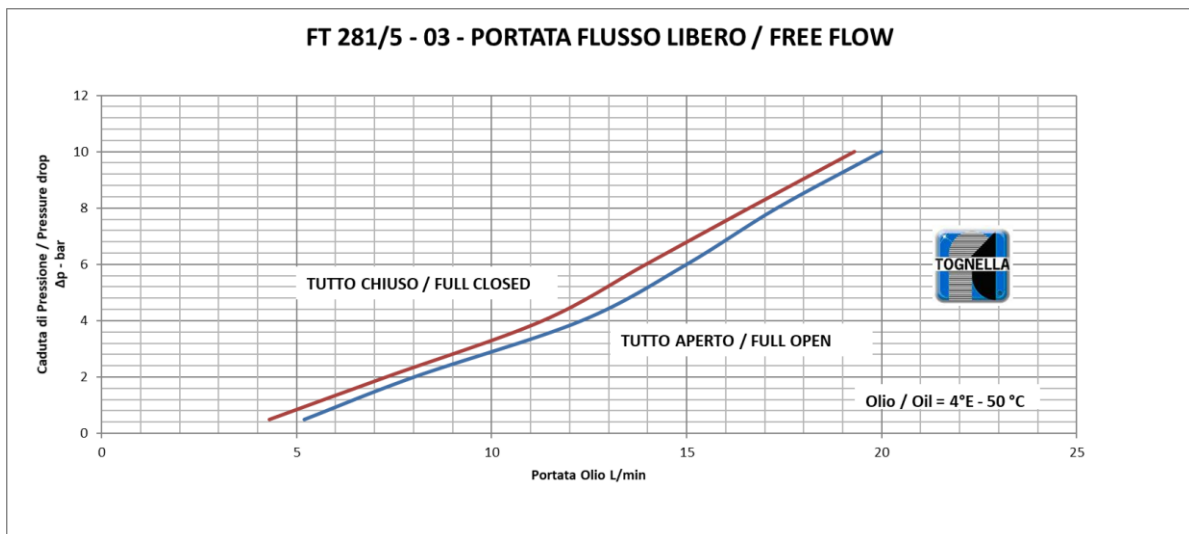
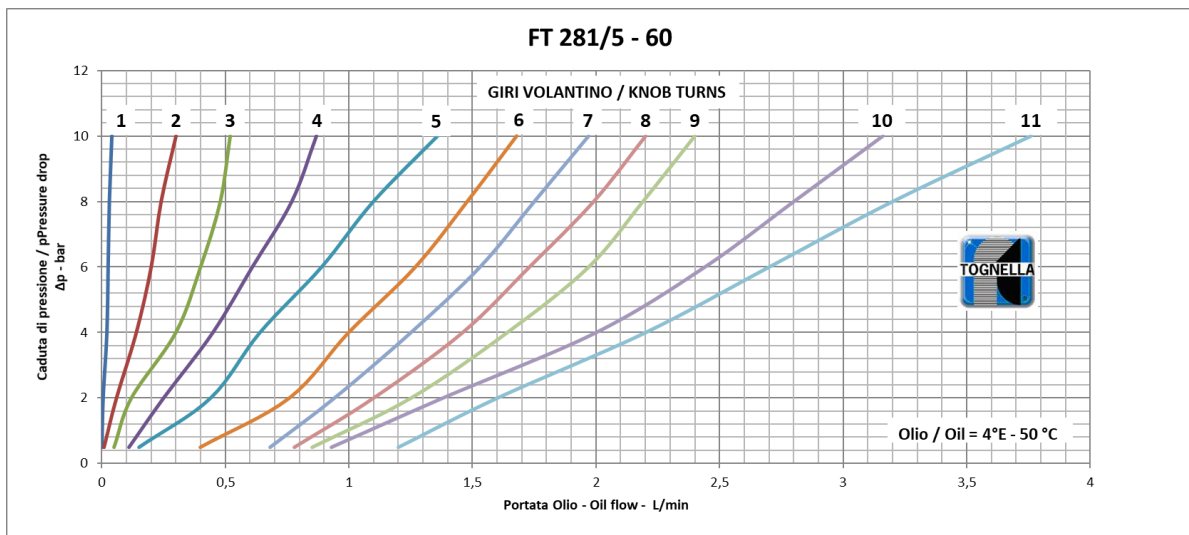
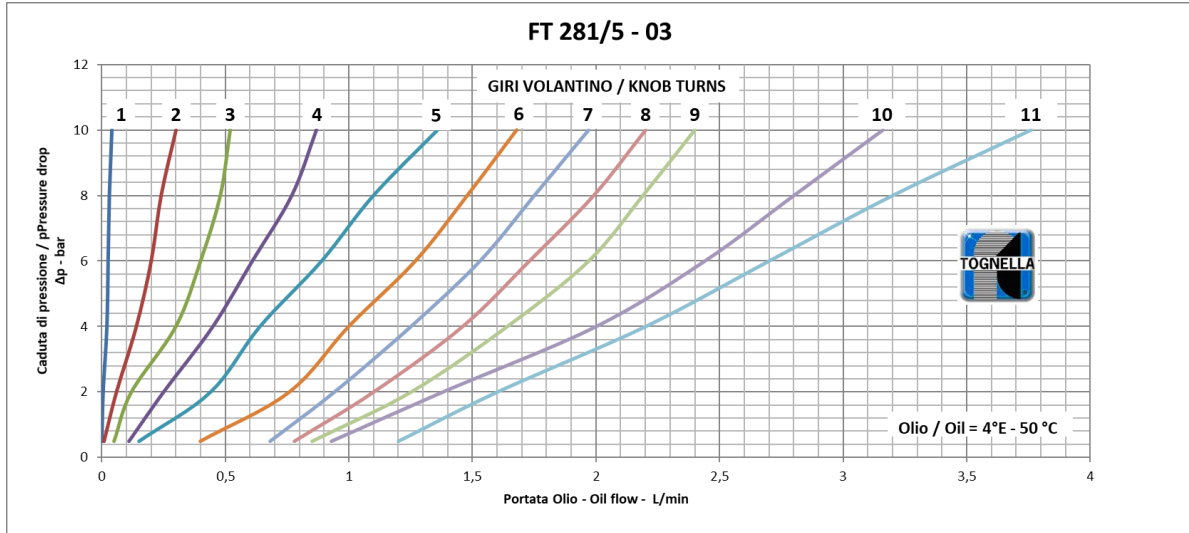



FT 281/5 - 60 - PORTATA FLUSSO LIBERO / FREE FLOW

