

GATE VALVE

700 HJ/JJ PN 63-100 DN 200-300

Design highlights

- Forged body and bonnet
- Seat armoured
- Bolted bonnet with male and female connection
- Almost full bore
- Non-rotating, rising stem

Advantages

- Homogeneous joining, free of pores and cavities compared to cast steel, sturdy and heavy duty
- High, long-term wear resistance in seat
- Blow-out-proof seal
- No constriction in seat
- Minimum packing wear

Version

- Flexible wedge gate with shut-off option / split wedge design = version JJ
- Flexible wedge design = version HJ
- Body and bonnet forged
- Body with almost full bore
- External stem thread
- Non-rotating, rising stem
- Needle bearing yoke sleeve
- Available with flanged and butt-weld connections

Materials

- 1.0460
- 1.5415
- 1.7335
- 1.7383

Other materials available on request.

Flow medium

Depending on the choice of materials, the gate valves can be used for water, steam, gas, oil or other non-aggressive media.

Applications

In chemical, industrial and power plants, and in shipbuilding.

Operating data

- Operating pressure, welded ends, up to 100 bar (DIN 2401)
- Operating pressure, flange ends, up to 100 bar (DIN 2401)
- Operating temperature up to 600 °C

Area of application

Permissible operating pressure [bar(g)] at calculation temperature [°C] ¹⁾

Material	PN	-60	-10	20	120	150	200	250	300	350	400	450	475	480	500	510	520	530	540	550	560	570	580	590	600	
1.0460	63		63	63	63	58	50	45	40	36	32	21	14	12												
	100		100	100	100	91	80	70	60	56	50	34	21	19												
1.5415	63		63	63	63	63	63	63	56	50	47	45	37	35	29	22	16	14								
	100		100	100	100	100	100	100	87	78	74	70	57	54	45	34	27	22								
1.7335	63		63	63	63	63	63	63	63	61	58	56	53	51	47	40	32	25	20	16	13	10				
	100		100	100	100	100	100	100	100	95	91	87	82	80	74	62	49	38	31	24	19	16				
1.7383 ²⁾	63		63	63	63	63	63	63	63	62	62	60	55	53	47	40	35	28	25	22	18	15	12	11	9	
	100		100	100	100	100	100	100	100	98	96	94	85	82	74	62	53	43	39	33	27	23	19	17	15	

1) Operating temperature = calculation temperature minus temperature surcharge according to the standard codes.

2) For temperatures > 570 °C, stem material 1.4980, seat armoured with Stellite, and high-temperature packing.

Flange version

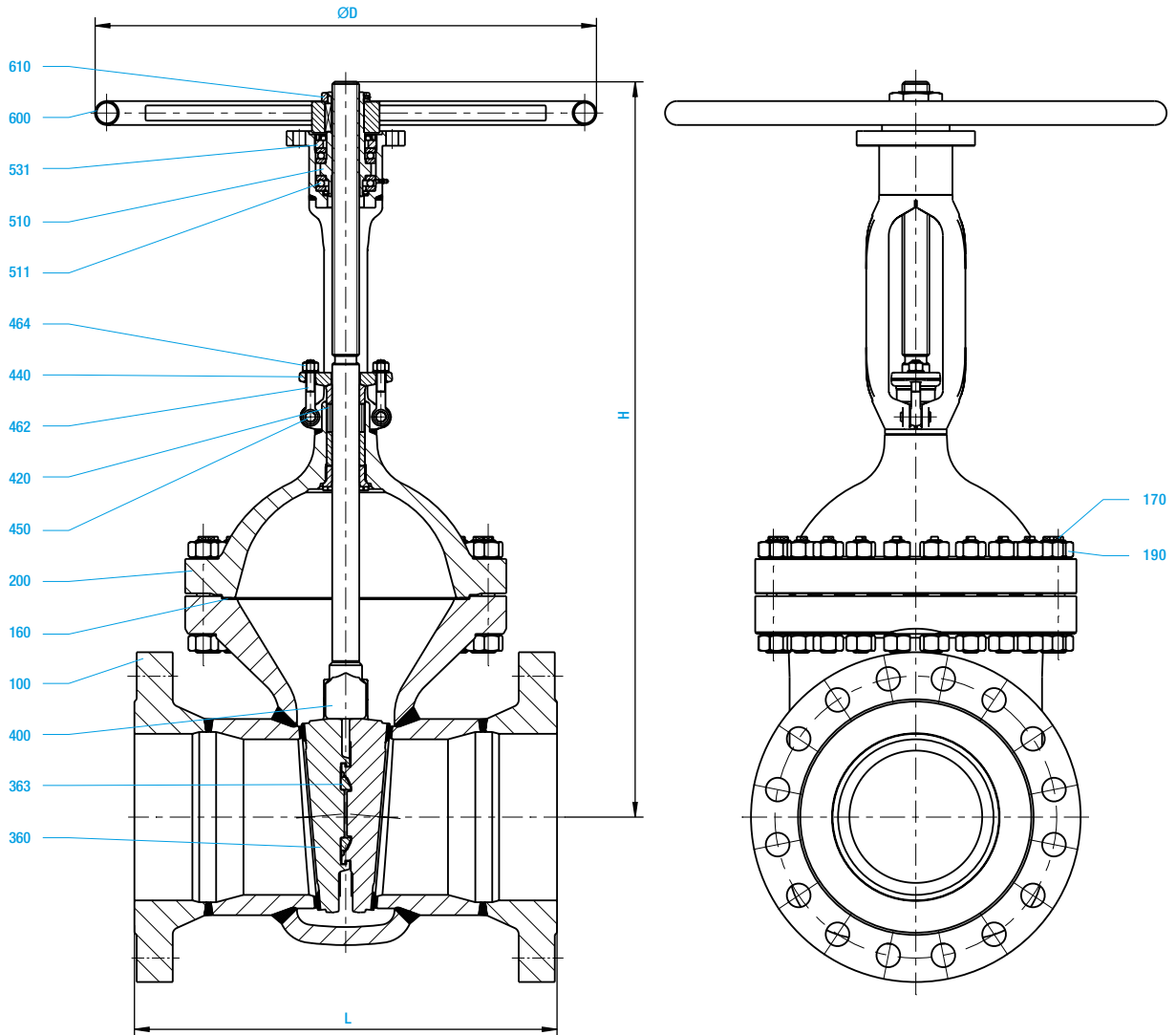

Butt-weld end version

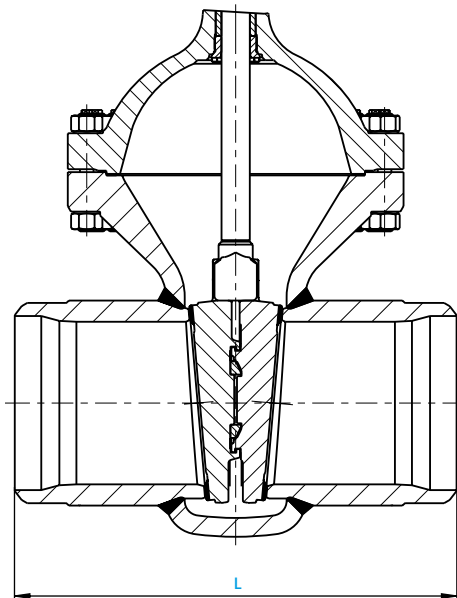

Materials

Item	Designation	1.0460 (21)	1.5415 (42)	1.7335 (44)	1.7383 (45)
100	Body	1.0460 ¹⁾	1.7383/1.5415 ²⁾	1.7383/1.7335 ²⁾	1.7383 ²⁾
160	Gasket	Grooved profile with graphite layer			
170	Bolt	1.7709	1.7709	1.7709	1.7709
190	Hexagonal nut	1.7218	1.7218	1.7218	1.7218
200	Bonnet	1.7383	1.7383	1.7383	1.7383
360	Disc	1.7383 ²⁾	1.7383 ²⁾	1.7383 ²⁾	1.7383 ²⁾
363	Pressure piece	1.4122	1.4122	1.4122	1.4122
400	Stem	1.4021	1.4122	1.4122	1.4122
420	Packing	Graphite			
440	Gland flange	1.0460	1.0460	1.0460	1.0460
450	Pin	St			
462	Bolt	1.1181 ³⁾	1.1181 ³⁾	1.1181 ³⁾	1.1181 ³⁾
464	Hexagonal nut	1.1181 ⁴⁾	1.1181 ⁴⁾	1.1181 ⁴⁾	1.1181 ⁴⁾
510	Yoke sleeve	1.0718 ⁵⁾	1.0718 ⁵⁾	1.0718 ⁵⁾	1.0718 ⁵⁾
511	Anti-friction bearing	WLS _t			
531	Threaded connection	1.0718	1.0718	1.0718	1.0718
600	Handwheel	St			
610	Hexagonal nut	St			

Spare parts

- 1) Armoured with 18/8
- 2) Armoured with Stellite
- 3) >= DN250 1.7709
- 4) >= DN250 1.7218
- 5) >= DN250 CW713R

Dimensions/mm

DN	PN	63-100		Stroke length	Rev/stroke	ØD
		ØDS	L			
200		199	550	210	37.5	600
250		235	650	265	37.5	720
300		276	750	313	40	890

Weights/kg and Kvs value m³/h

DN	PN	63	100	63-100	Kvs
		Flange		Butt-weld ends	[m ³ /h]
200		287	307	223	4000
250		491	542	436	6247
300		727	811	650	8997