

PM500FE SERIE

TECHNICAL DOCUMENTATION

SUMMARY

1 - Presentation of the Power Moller® product range	Page 3
2 - Presentation of the series	Page 4
General characteristics	Page 4
Structure and description	Page 6
Applications	Page 6
Characteristics depending on circuit board	Page 7
3 - Transfer capacity	Page 9
Driven by ribbed belts	Page 9
Stopping distance according to the weight and type of load being conveyed	Page 11
4 - Presentation of the different fixing options	Page 12
5 - Dimensional characteristics	Page 14
Grooved tube - Hexagonal shaft with spring on free end	Page 14
Grooved tube - M8 threaded shaft with screw on free end	Page 15
Roller with pulley for ribbed belt - Hexagonal shaft with spring on free end	Page 16
Roller with pulley for ribbed belt - M8 threaded shaft with screw on free end	Page 17
Roller with pulley for round belt - Hexagonal shaft with spring on free end	Page 18
Roller with pulley for round belt - M8 threaded shaft with screw on free end	Page 19
Roller without drive - Hexagonal shaft with spring on free end	Page 20
Roller without drive - M8 threaded shaft with screw on free end	Page 21
6 - Dimensional characteristics - Curve	Page 22
Conical roller with grooved tube - Ri = 800mm	Page 22
Conical roller with pulley for ribbed belt - Ri = 800mm	Page 23
Conical roller with pulley for round belt - Ri = 800mm	Page 24
Conical roller with grooved tube - Ri = 850mm	Page 25
Conical roller with pulley for ribbed belt - Ri = 850mm	Page 26
Conical roller with pulley for round belt - Ri = 850mm	Page 27
7 - Dimensional characteristics - miscellaneous	Page 28
PVC sleeve	Page 28
Coated in natural rubber, nitrile rubber and polyurethane	Page 28
8 - Belt conveyor application	Page 29
Condition of use and recommendation	Page 29
Structure	Page 29
Transfer capacity	Page 30
Dimensional characteristics and weight	Page 33
Tube specification	Page 34
9 - Mounting on the frames	Page 35
Mounting plate for plain 11.1 mm hexagonal shaft - FLAT ON TOP	Page 35
Mounting plate for plain 11.1 mm hexagonal shaft - ANGLE ON TOP	Page 35
Mounting plate for threaded hexagonal shaft - FLAT ON TOP	Page 36
Mounting plate for threaded hexagonal shaft - ANGLE ON TOP	Page 36
M8 threaded fixed shaft	Page 36
10 - Wiring	Page 37
With CBM-105 circuit board	Page 37
With HB510 circuit board	Page 37
11 - Accessories	Page 38
Ribbed belt	Page 38
Extension cables	Page 38
Rounded belts	Page 39
24 VDC power supply	Page 39
24 VDC distribution connector	Page 39
12 - Product identification	Page 40
Round label	Page 40
Square label	Page 40
Annex 1	Page 41

POWER MOLLER® solutions

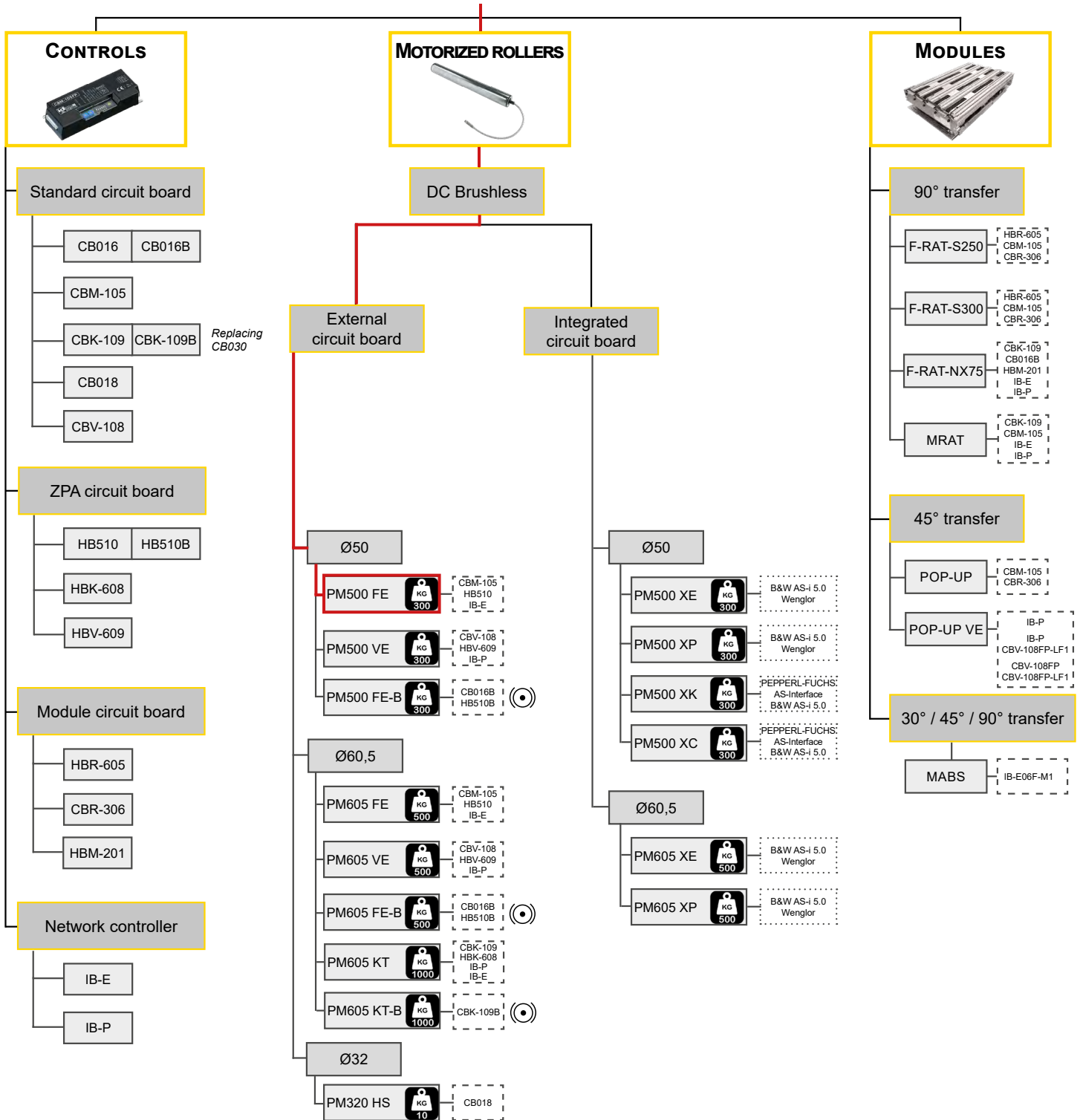

Corresponding circuit board
 Compatible module / sensor
 Max load to be conveyed
 Mechanical brake version

▶ 2 - PRESENTATION OF THE SERIES



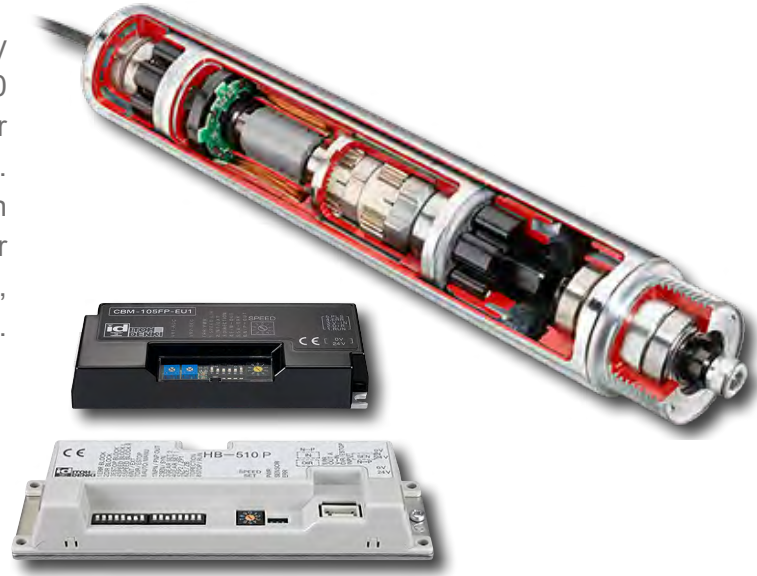









The motorized roller PM500FE with brushless technology 24VDC, used with circuit board CBM-105 or HB510 is designed for conveying light and medium loads for order preparation, distribution, and for assembly lines. This circuit board is separated from the gear-motor in order to optimize the performance, durability of the roller and to offer diverse functions such as pulse signals, acceleration/deceleration, optional position holder... The assembly can be controlled by PLC.



General characteristics

ELECTROMECHANICAL	Direct current and brushless 24 VDC	24 VDC (+ /- 10 %) – ripple ratio < 10 %			
	Insulation class	E			
	Operation at 40°C	Continuous	100%		
		Intermittent	1800 starts / hour maxi Minimum duty cycle = 1 s ON / 1 s OFF ED = ON / (ON+OFF) ≤ 50 %		
	Brake	Dynamic braking			
	Protection index	IP54 (IP65 or cold room, contact us)			
	Cable length	300 mm with JST connector - 9 pins			
	Protection	Thermal protection (>95°C for circuit board, >110°C for motor) Protection against induced voltage			
	Environment	0/+40 °C - no condensation - or corrosive or explosive atmosphere - Vibrations < 0,5 G			
	Sound level	≈ 52 dB nominal 1 metre away			
	Speed code	15	25	55	90
	Reduction ratio	1/44,90	1/26,67	1/12,64	1/7,5
	Connector	Male 9-pin JST#S9B-XH-A			
CONTROL	Circuit board functions	See the characteristics of CBM-105 (page 7) and HB510 (page 8)			

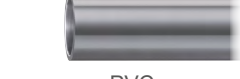
 The PM500FE drive roller is designed exclusively for indoor use.

<p>Shaft and flange motor side :</p>	 Plain hexagonal  Threaded hexagonal	<ul style="list-style-type: none"> • Plain hexagonal 11.1 mm shaft or M12 threaded • Heat-treated and phosphated steel shaft • Zamac (zinc, aluminium and magnesium alloy) endcaps
<p>Shaft and flange free side :</p>	 Hexagonal spring loaded  Set screw	<ul style="list-style-type: none"> • Smooth hexagonal 11.1mm shaft with spring, 12 mm M8 threaded flat metal strip • Heat-treated and phosphated steel shaft • Zamac (zinc, aluminium and magnesium alloy) flange
<p>Tube :</p>	 Zinc plated steel  Stainless steel	<ul style="list-style-type: none"> • Tube in precision cold drawn steel, ST37-2 quality, outer diam. 50 mm • Zinc-coated or stainless steel (304L)
<p>Pulleys :</p>	 Ribbed  Grooves	<p>Pulleys for :</p> <ul style="list-style-type: none"> • Ribbed belts, 8 teeth, Zamac (zinc, aluminium and magnesium alloy) • Round belts, diam. 4 or 5 mm with smooth • Hexagonal shaft with spring or M8 threaded shaft
<p>Grooves :</p>	 Grooves	<ul style="list-style-type: none"> • Grooves in different positions from 33 to 300 mm from the edge of the tube • Depth 5,8mm • For round belts Ø 4 or 5 mm
<p>Sleeve :</p>	 Tapered  PVC	<ul style="list-style-type: none"> • Conical plastic sleeve (PP) for inner radius (Ri) 800 or 850 mm • Grey PVC sleeve thickness 2 or 3 mm (~68 ShA), Black anti-static in option
<p>Lagging :</p>	 Polyurethane  Natural rubber / nitrile	<ul style="list-style-type: none"> • Polymerized polyurethane coating, thickness 3 mm, 90 ShA, grey • Natural hot vulcanized rubber coating, thickness 3 mm

Structure and description

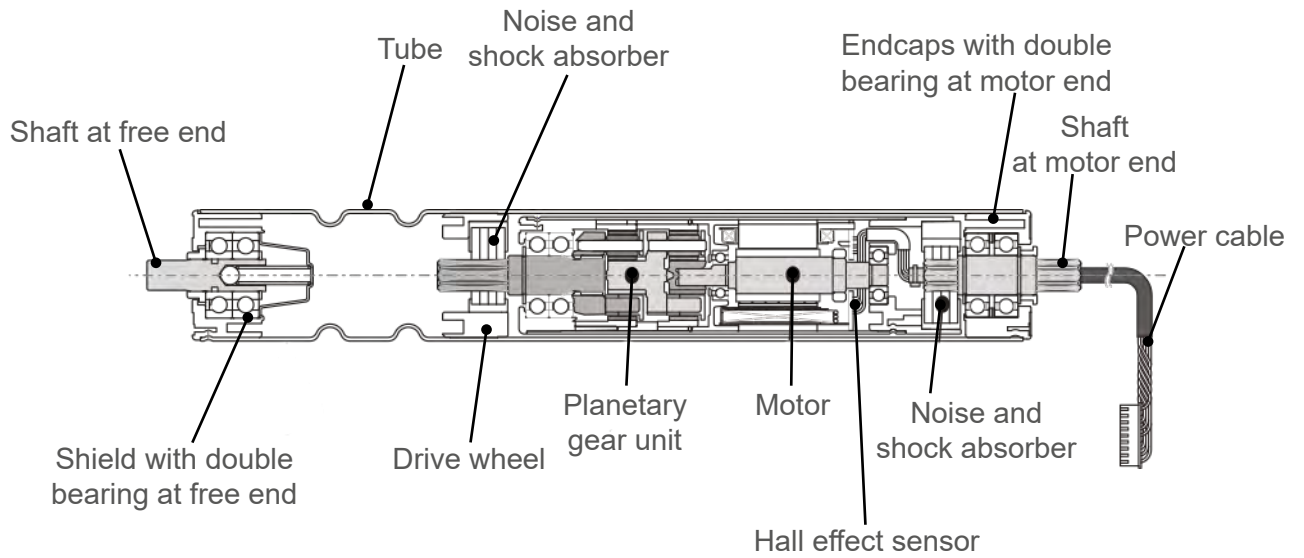

Applications

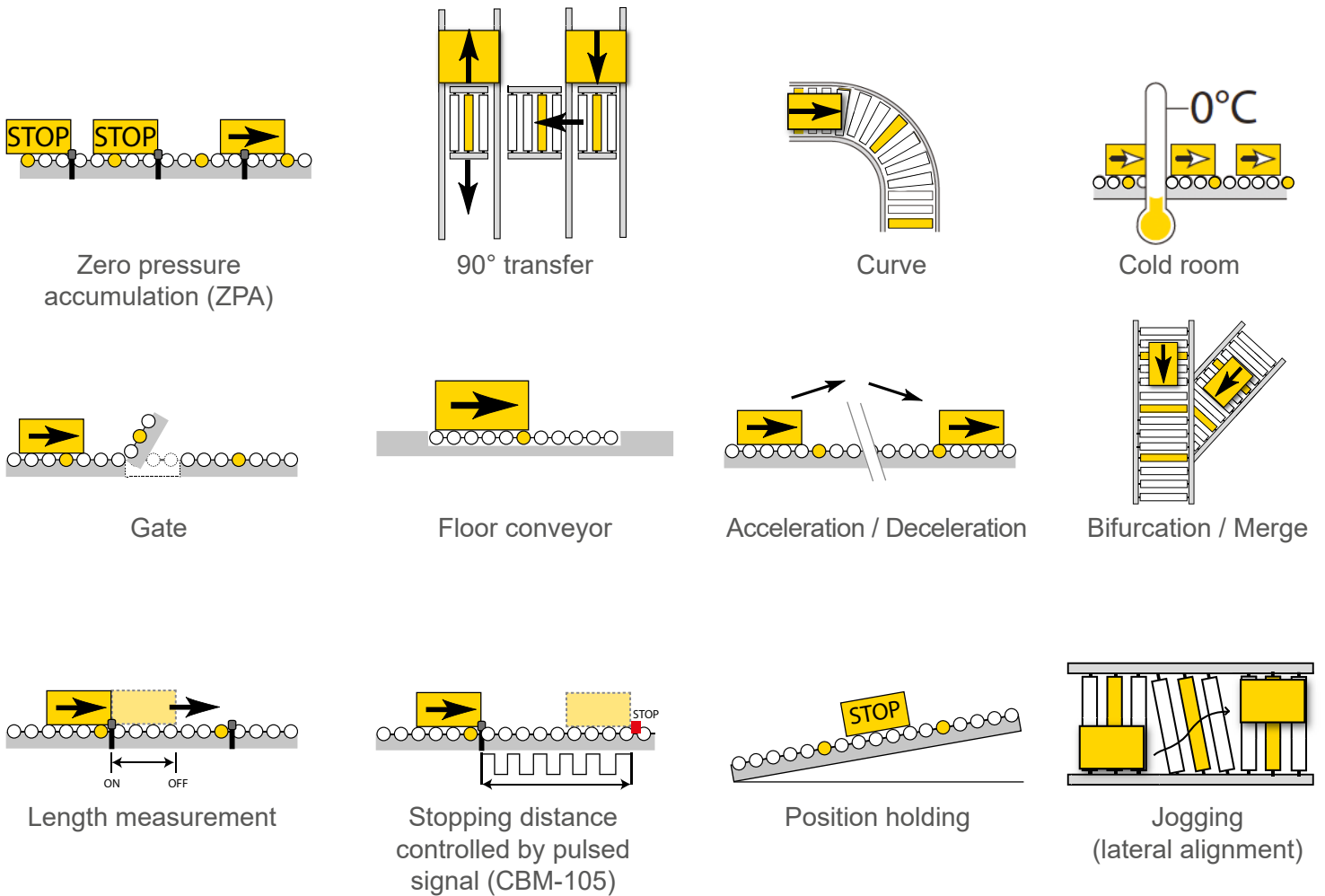

Characteristics depending on circuit board

WITH CBM-105

CHARACTERISTICS		SPEEDCODE15	SPEEDCODE25	SPEEDCODE55	SPEEDCODE90	
ELECTROMECHANIC	Motor	Direct current and brushless 24 VDC				
	Absorbed power (W)	nominal	25 - 67,2		28,8 - 64,8	
		start-up	96			
	Tangential force (N) *	nominal	133,9 - 143,9	78 - 86	42,8 - 46	20,9 - 27,9
		start-up	349,8	225	111,8	62,7
	Operation	Continuous or intermittent 1800 starts/h max. Minimum duty cycle : 1s ON / 1s OFF				
	Brake	Dynamic braking				
	Speed (m/min)	no load	2,2 - 17,4	3,7 - 29,3	7,7 - 61,7	13,0 - 104,0
	Protection index (motorized roller)	IP54, 65 (<i>Contact us for other classes</i>)				
	Length	285 to 1200 mm**	260 to 1200 mm**	260 to 1200 mm**	225 to 1200 mm**	
Static load max.	300 - 1200 mm** = 65 - 15 kg per roller					
CONTROL	Input signal	Start / Stop, Direction of rotation				
	Selection of rotation direction	By dip switch (CW/CCW) or input signal				
	Speed setting	20 speeds with a rotating switch				
		20 speeds by external analog voltage of 0-10VDC				
	Acceleration / Deceleration	Adjustable with potentiometer from 0 to 2,5s				
	Servo-brake activation	ON/OFF by dip switch				
	Pulse signal output (imp./tour)	89,9	53,34	25,28	15	
	Error signal out-put	Over-heating, wiring error, under-voltage, over-voltage...				
Protection	Against polarity reversal 0/24V and power backfeed, fuse, integrated thermal protection					

* Data measured in high ambient temperature (+40°C, max. recommended temp. of use)

For other specifications, please contact us.

** Please consult us for tube lengths over 1200mm.

WITH HB510

CHARACTERISTICS		SPEEDCODE15	SPEEDCODE25	SPEEDCODE55	SPEEDCODE90	
ELECTROMECHANIC	Motor	Direct current and brushless 24 VDC				
	Absorbed power (W)	nominal	29,3 - 60	28,8 - 61,9	29,3 - 60	28,8 - 61,9
		start-up	96			
	Tangential force (N) *	nominal	118,6 - 127,1	67,7 - 75,0	37,9 - 40,6	21,5 - 24,0
		start-up	349,8	225,5	111,8	72,2
	Operation	Continuous or intermittent 1800 starts/h max. Minimum duty cycle : 1s ON / 1s OFF				
	Brake	Dynamic braking				
	Speed (m/min)	no load	4,3 - 17,4	7,3 - 29,3	15,4 - 61,7	26,0 - 104,0
	Protection index (motor roller)	IP54, 65, cold room (Contact us for other classes)				
	Length		285 to 1200 mm**	260 to 1200 mm**	260 to 1200 mm**	230 to 1200 mm**
Static load max.	300 - 1200 mm** = 65 - 15 kg per roller					
CONTROL	Speed setting	10 speeds with a rotating switch				
		10 speeds by external analog voltage of 0-10VDC				
	Error signal in-put	Over-heating, wiring error, under-voltage, over-voltage...				
	Sensor output signal	Recovery sensor state for PLC				
	Protection	Against polarity reversal 0/24V and power backfeed, fuse, integrated thermal protection				
	Sensor timer	Timing sequence of the motorized roller depending on the sensor status of the downstream zone				
	Run holding timer	Timing sequence of the motorized roller depending on the sensor status of the zone to be left				
	Jam timer	Jam/blockage detection of the load depending on the sensor status time				
	Emergency stop	Stop of the motorized rollers of all the defined zones				
	Transfer mode	Selection of train mode or singulation mode by dip switch				
	Transfer direction and logic	Invert the direction of travel and logic for all the defined zones				
	Synchronization function	Synchronization of several motorized rollers in the same zone				
	Forced Start / Forced Stop	The forced start enables evacuating the load of the last zone The forced stop enables inserting load in a defined location				
	Speed control block area	Speed variation simultaneous and synchronized of several motorized rollers				
Modification program	Contact us					

* Data measured in high ambient temperature (+40°C, max. recommended temp. of use)

** Please consult us for tube lengths over 1200mm.

3 - TRANSFER CAPACITY

Driven by ribbed belts

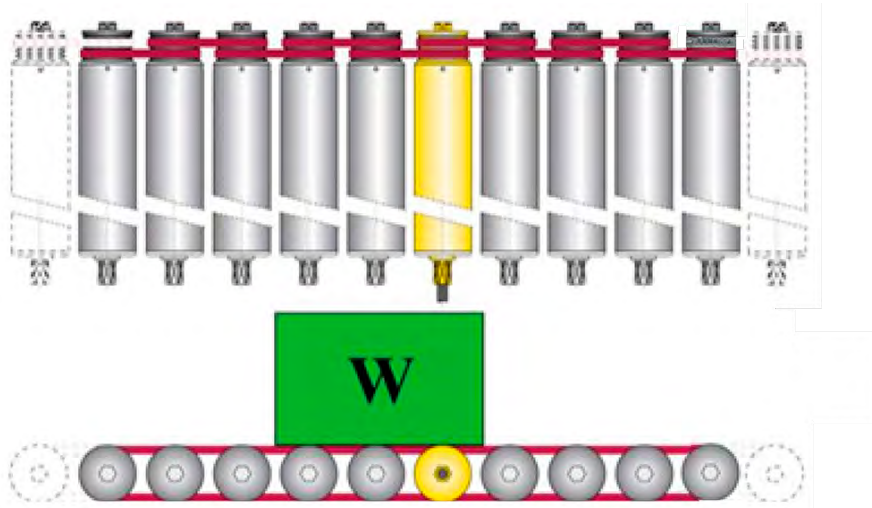

WITH CBM-105

PM500FE 15m/min

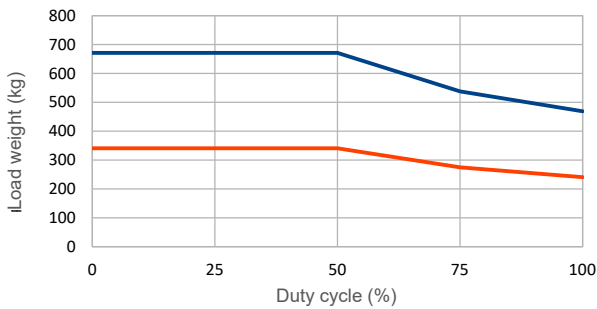

PM500FE 25m/min

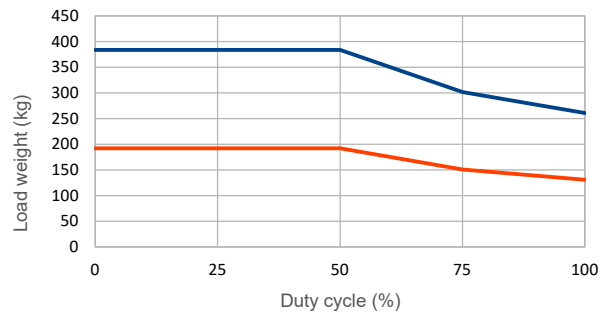

PM500FE 55m/min

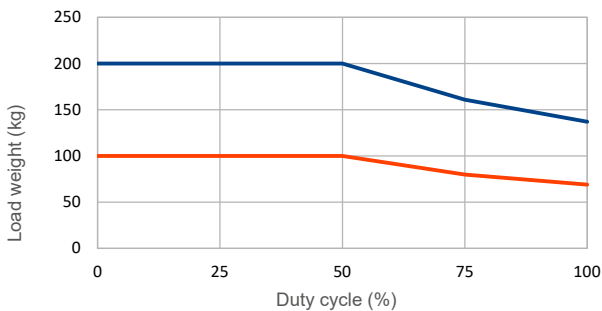

- Load to transport
 - Plastic box ($\mu = 0,03$)
 - Cardboard box ($\mu = 0,06$)
- 9 slave rollers driven by 1 motorized roller
- Ambient temperature of 30 °C

These curves are given as a guide. Transfer capacity depends on the nature and quality of the transported load, the belt tension, the quality of the bearings, the nature of the sleeves, the ambient temperature...

Due to the maximum static load of the PM500FE which is 300 kg max, note that practically the PM500FE can't convey more than 300 kg.



WITH HB510

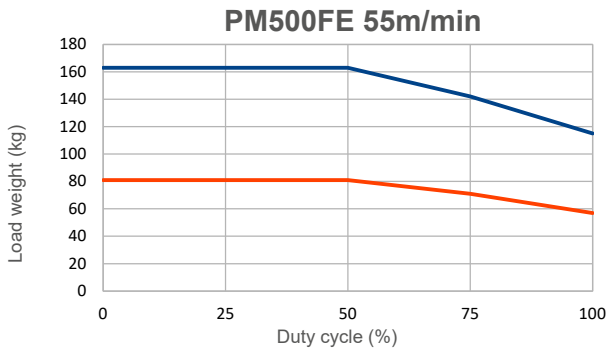
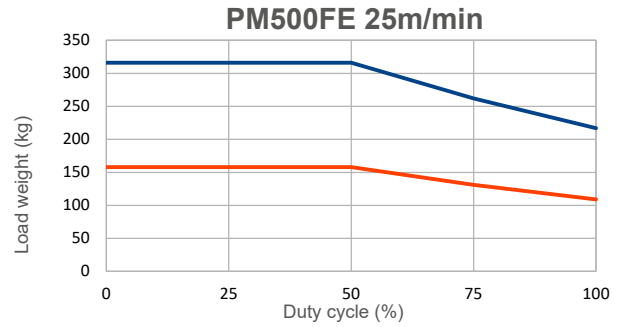
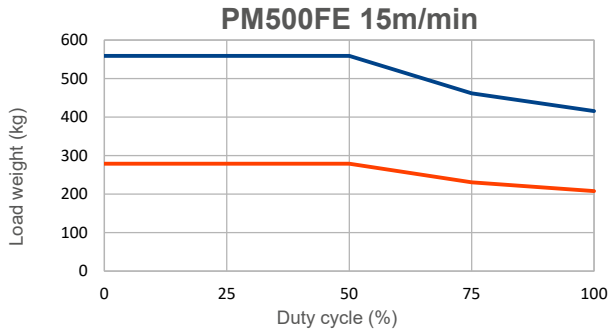

- Load to transport
 - Plastic box ($\mu = 0,03$)
 - Cardboard box ($\mu = 0,06$)
- 9 slave rollers driven by 1 motorized roller

These curves are given as a guide. Transfer capacity depends on the nature and quality of the transported load, the belt tension, the quality of the bearings, the nature of the sleeves, the ambient temperature...

Due to the maximum static load of the PM500FE which is 300 kg max, note that practically the PM500FE can't convey more than 300 kg.



Stopping distance according to the weight and type of load being conveyed

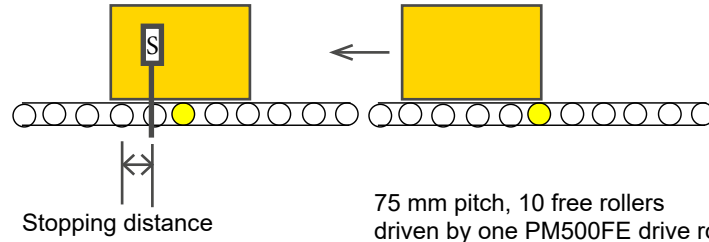

75 mm pitch, 10 free rollers
driven by one PM500FE drive roller - 55 m/min
Cardboard box : W : 380mm x L : 560 mm
Plastic box : W : 390mm x L : 590 mm

DRIVEN BY ROUND BELTS Ø5MM

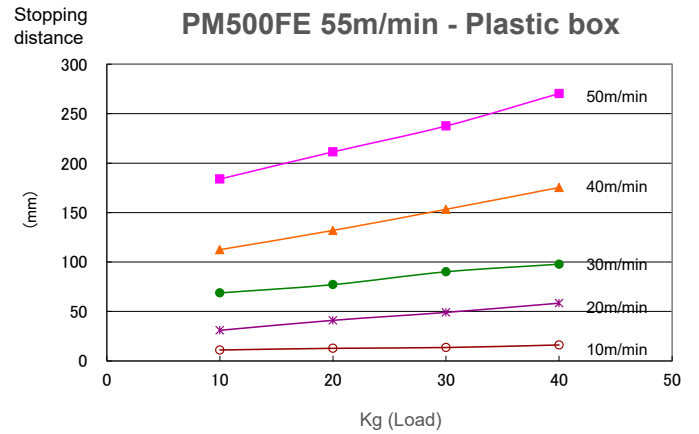
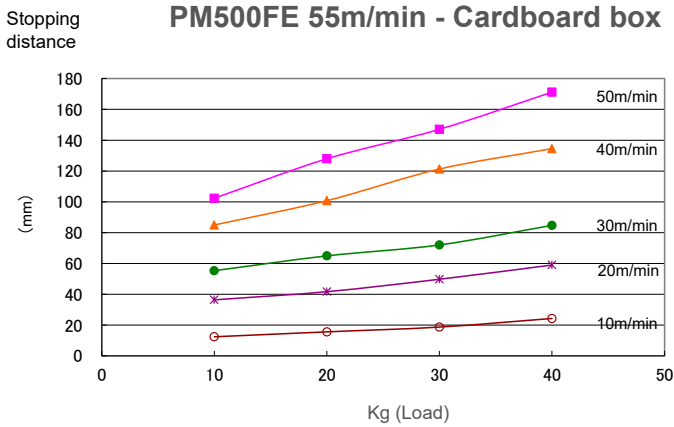



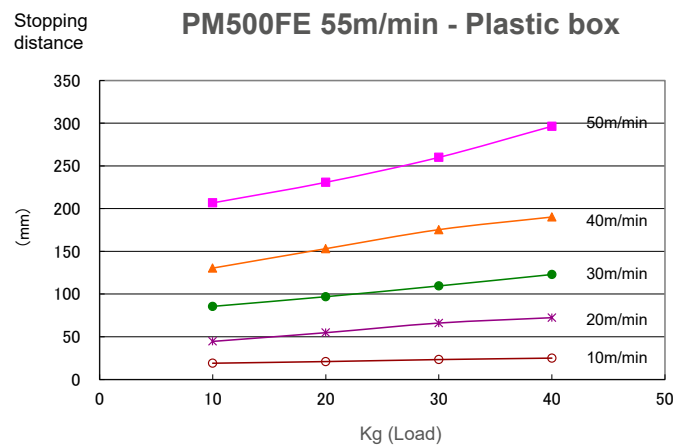
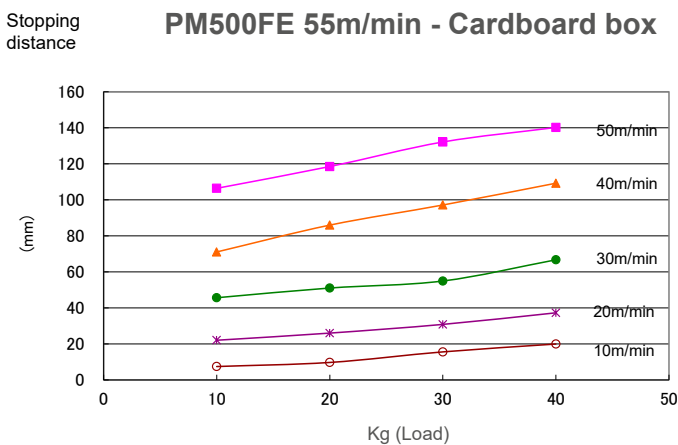





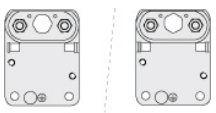









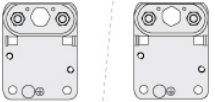
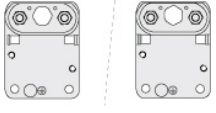
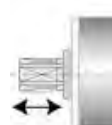

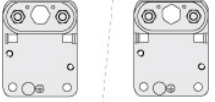
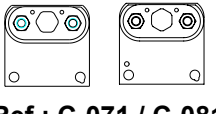
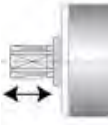

DRIVEN BY RIBBED BELTS

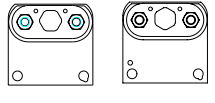
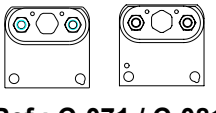
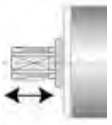

The items in this document are indicative.

4 - PRESENTATION OF THE DIFFERENT FIXING OPTIONS

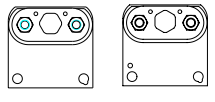
FREE SIDE FIXING		MOTOR SIDE FIXING	
 Ref : A-071-G / A-081-G <i>(optional)</i>			 Ref : AM-FE-F / AM-FE-A <i>(obligatory)</i>
 Screw M8 x 14 Ref : SP-M8-14 <i>(obligatory)</i>			 Ref : AM-FE-F / AM-FE-A <i>(obligatory)</i>
			 Ref : A-071-G / A-081-G <i>(obligatory)</i>
 Ref : A-071-G / A-081-G <i>(optional)</i>			 Ref : A-071-G / A-081-G <i>(obligatory)</i>
 Ref : C-071 / C-081 <i>(optional)</i>			 Ref : AM-FE-F / AM-FE-A <i>(obligatory)</i>
 Screw M8 x 14 Ref : SP-M8-14 <i>(obligatory)</i>			 Ref : AM-FE-F / AM-FE-A <i>(obligatory)</i>
			 Ref : C-071 / C-081 <i>(obligatory)</i>
 Ref : C-071 / C-081 <i>(optional)</i>			 Ref : C-071 / C-081 <i>(obligatory)</i>

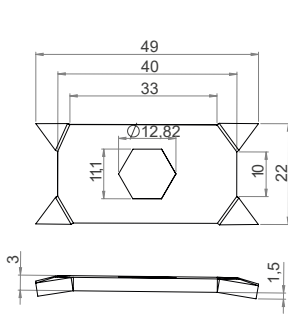

Ref : P-0B1

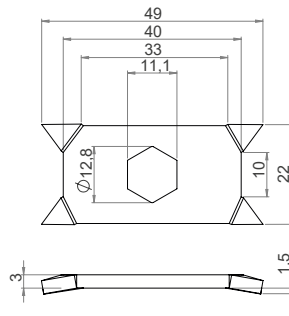

Ref : P-0C1

Ref : FEY02

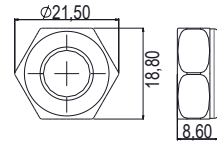

Note :
Nut ref. FEY02 should be used with the claw plate ref. P-0B1 or P-0C1.

P-0B1 + FEY02

P-0C1 + FEY02

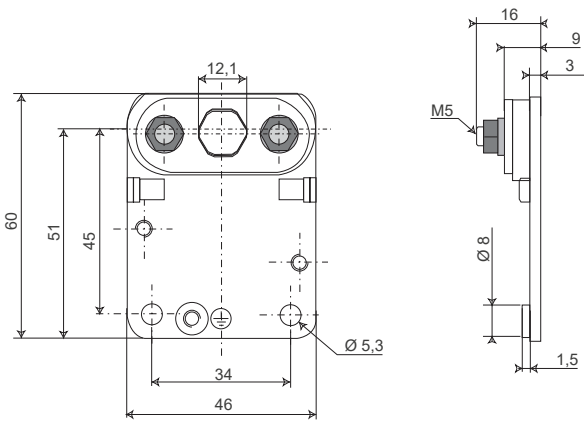

Ref : A-071-G

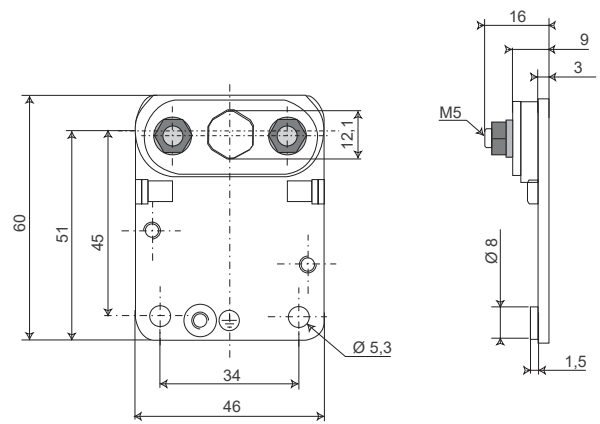

Ref : A-081-G

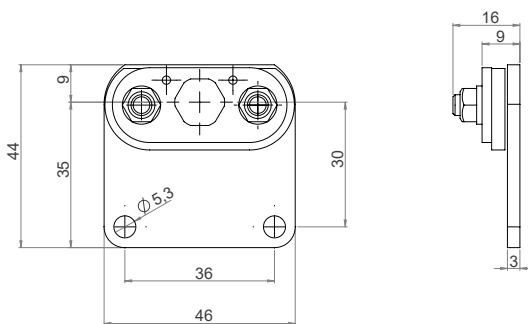
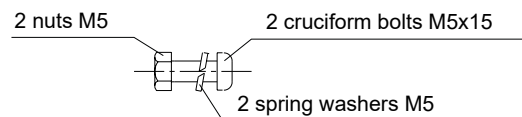
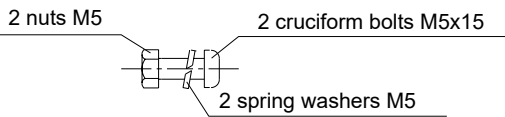

Ref : C-071

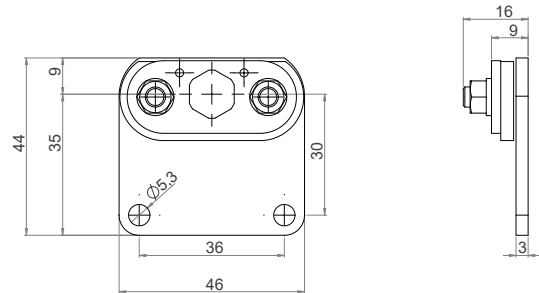

Ref : C-081

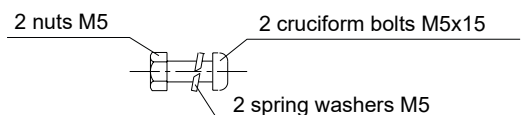
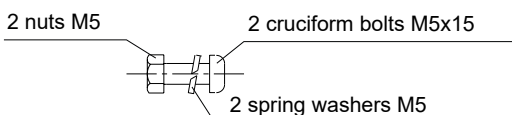

5 - DIMENSIONAL CHARACTERISTICS

Grooved tube - Hexagonal shaft with spring on free end

PM500FE - Hexagonal threaded shaft motor side and hexagonal shaft with spring on free end

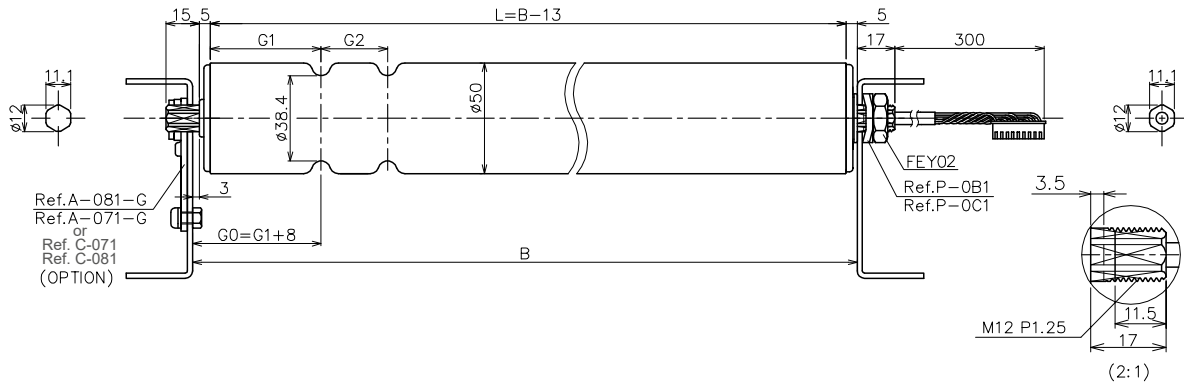

PM500FE - Hexagonal plain shaft motor side and hexagonal shaft with spring on free end

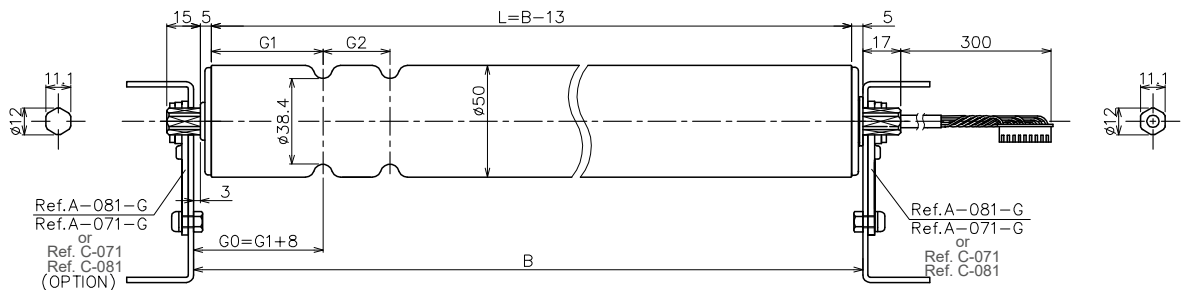

Dimensions PM500FE

STEEL TUBE

Speed code	Dimension (B)	Tube length (L)	Grooves for steel tube Depth = 5.8mm			
	mini $\leq B \leq$ max	mini $\leq L \leq$ max**	G0 mini	G1 mini	G2 mini	G1+G2 max
15	$283+G1+G2 \leq B \leq 1213$	$270+G1+G2 \leq L \leq 1200$				
25 / 55	$253+G1+G2 \leq B \leq 1213$	$240+G1+G2 \leq L \leq 1200$	≥ 41	≥ 33	≥ 22	≤ 300
90	$223+G1+G2 \leq B \leq 1213$	$210+G1+G2 \leq L \leq 1200$				

STAINLESS STEEL TUBE

Speed code	Dimension (B)	Tube length (L)	Grooves for stainless steel tube* Depth = 5,2mm			
	mini $\leq B \leq$ max	mini $\leq L \leq$ max**	G0 mini	G1 mini	G2 mini	G1 + G2 max
15	$283+G1+G2 \leq B \leq 1213$	$270+G1+G2 \leq L \leq 1200$				
25 / 55	$253+G1+G2 \leq B \leq 1213$	$240+G1+G2 \leq L \leq 1200$	≥ 41	≥ 33	≥ 30	≤ 300
90	$223+G1+G2 \leq B \leq 1213$	$210+G1+G2 \leq L \leq 1200$				

⚠ For a single groove $G2=0$.

⚠ *Stainless steel tube : For IP54 version

** Please consult us for tube lengths over 1200mm.

WEIGHT / STATIC LOAD / AXIAL FORCE

Tube length		300	400	500	600	700	800	900	1000	1100	1200
Weight (Kg)	15 m/min	2,6	2,8	2,9	3,1	3,3	3,4	3,6	3,7	3,9	4,1
	25m/min	2,4	2,5	2,7	2,9	3,0	3,2	3,4	3,5	3,7	3,9
	55m/min	2,4	2,6	2,7	2,9	3,1	3,2	3,4	3,6	3,7	3,9
	90m/min	2,1	2,3	2,4	2,6	2,8	2,9	3,1	3,3	3,4	3,6
Static load max (kg)		65	55	45	35	30	25	20	20	15	10
Axial force max (N)		290									

Grooved tube - M8 threaded shaft with screw on free end

PM500FE - Hexagonal threaded shaft motor side and M8 threaded shaft with screw on free end

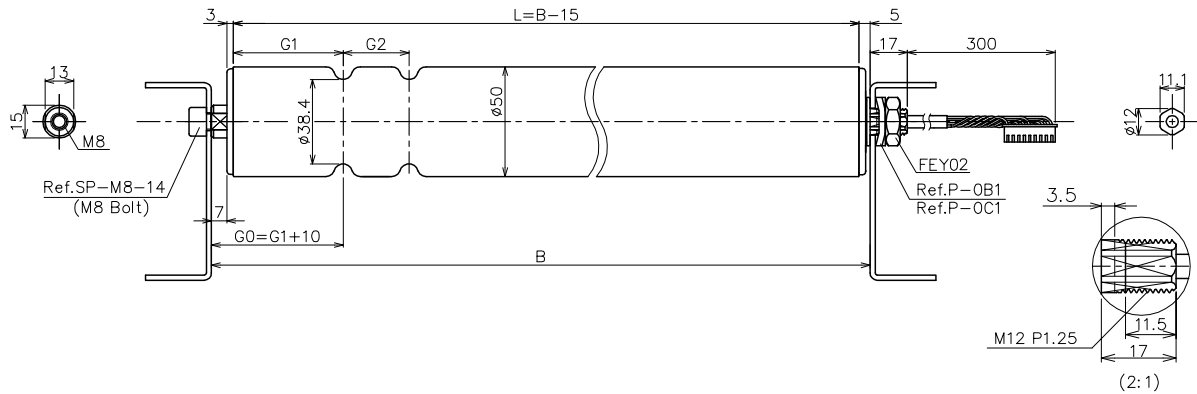

PM500FE - Hexagonal plain shaft motor side and M8 threaded shaft with screw on free end

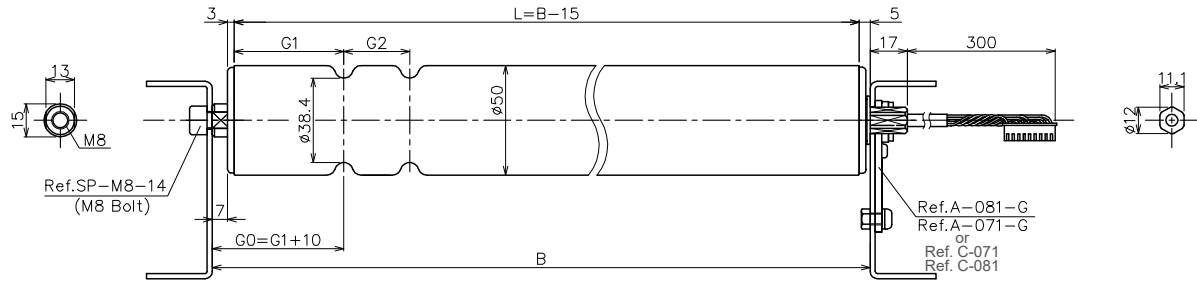

Dimensions PM500FE

STEEL TUBE

Speed code	Dimension (B)	Tube length (L)	Grooves for steel tube Depth = 5.8mm			
	mini ≤ B ≤ max	mini ≤ L ≤ max**	G0 mini	G1 mini	G2 mini	G1+G2 max
15	285+G1+G2 ≤ B ≤ 1215	270+G1+G2 ≤ L ≤ 1200				
25 / 55	255+G1+G2 ≤ B ≤ 1215	240+G1+G2 ≤ L ≤ 1200	≥ 43	≥ 33	≥ 22	≤ 300
90	225+G1+G2 ≤ B ≤ 1215	210+G1+G2 ≤ L ≤ 1200				

STAINLESS STEEL TUBE

Speed code	Dimension (B)	Tube length (L)	Grooves for stainless steel tube* Depth = 5.2mm			
	mini ≤ B ≤ max	mini ≤ L ≤ max**	G0 mini	G1 mini	G2 mini	G1+G2 max
15	285+G1+G2 ≤ B ≤ 1215	270+G1+G2 ≤ L ≤ 1200				
25 / 55	255+G1+G2 ≤ B ≤ 1215	240+G1+G2 ≤ L ≤ 1200	≥ 43	≥ 33	≥ 30	≤ 300
90	225+G1+G2 ≤ B ≤ 1215	210+G1+G2 ≤ L ≤ 1200				

⚠ For a single groove G2=0.

⚠ *Stainless steel tube : For IP54 version

** Please consult us for tube lengths over 1200mm.

WEIGHT / STATIC LOAD / AXIAL FORCE

Tube length		300	400	500	600	700	800	900	1000	1100	1200
Weight (Kg)	15 m/min	2,6	2,8	2,9	3,1	3,2	3,4	3,6	3,7	3,9	4,1
	25m/min	2,4	2,5	2,7	2,9	3,0	3,2	3,4	3,5	3,7	3,9
	55m/min	2,4	2,6	2,7	2,9	3,1	3,2	3,4	3,6	3,7	3,9
	90m/min	2,1	2,3	2,4	2,6	2,8	2,9	3,1	3,3	3,4	3,6
Static load max (kg)		65	55	45	35	30	25	20	20	15	10
Axial force max (N)		290									

Roller with pulley for ribbed belt - Hexagonal shaft with spring on free end

PM500FE - Hexagonal threaded shaft motor side and hexagonal shaft with spring on free end

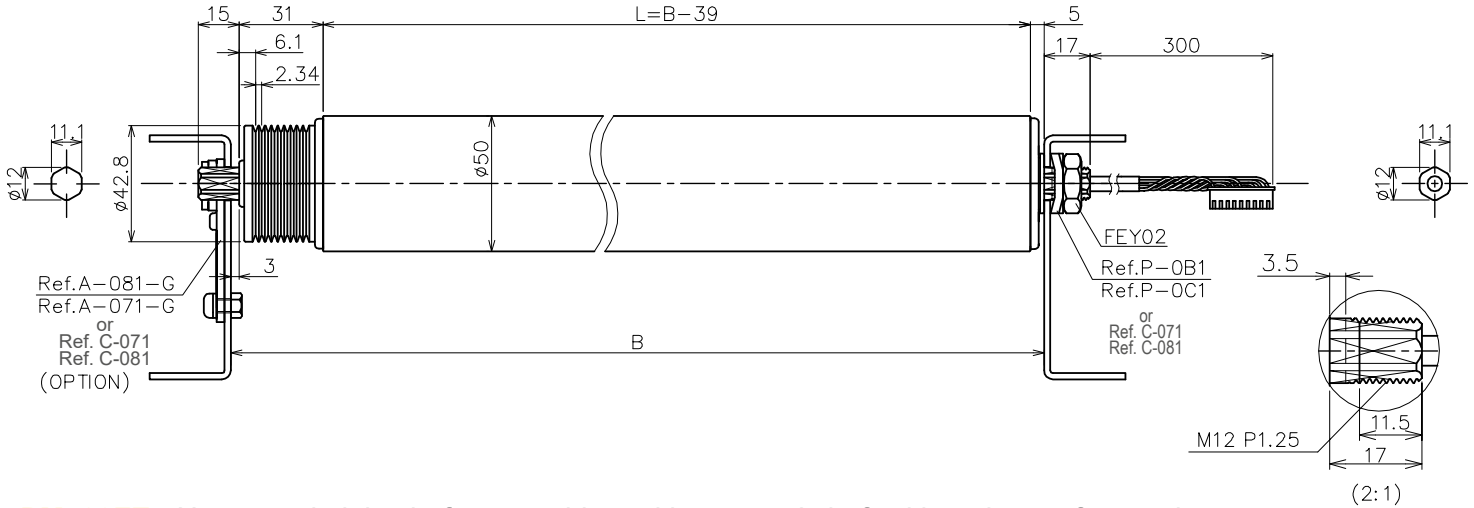

PM500FE - Hexagonal plain shaft motor side and hexagonal shaft with spring on free end

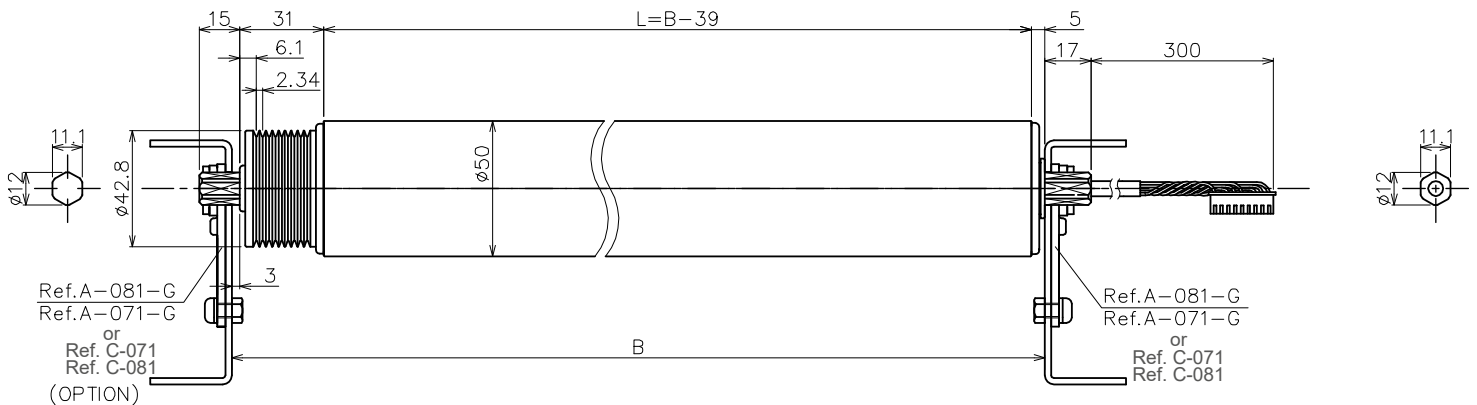

Dimensions PM500FE

Speed code	Dimension (B)	Tube length (L)
	mini ≤ B ≤ max	mini ≤ L ≤ max**
15	334 ≤ B ≤ 1239	295 ≤ L ≤ 1200
25 / 55	309 ≤ B ≤ 1239	270 ≤ L ≤ 1200
90	279 ≤ B ≤ 1239	240 ≤ L ≤ 1200

** Please consult us for tube lengths over 1200mm.

WEIGHT / STATIC LOAD / AXIAL FORCE

Tube length		300	400	500	600	700	800	900	1000	1100	1200
Weight (Kg)	15 m/min	2,8	2,9	3,1	3,2	3,4	3,6	3,7	3,9	4,1	4,2
	25m/min	2,5	2,7	2,9	3,0	3,2	3,4	3,5	3,7	3,9	4,0
	55m/min	2,6	2,7	2,9	3,1	3,2	3,4	3,6	3,7	3,9	4,0
	90m/min	2,3	2,4	2,6	2,8	2,9	3,1	3,2	3,4	3,6	3,7
Static load max (kg)		65	55	45	35	30	25	20	20	15	10
Axial force max (N)		290									

Roller with pulley for round belt - Hexagonal shaft with spring on free end

PM500FE - Hexagonal threaded shaft motor side and hexagonal shaft with spring on free end

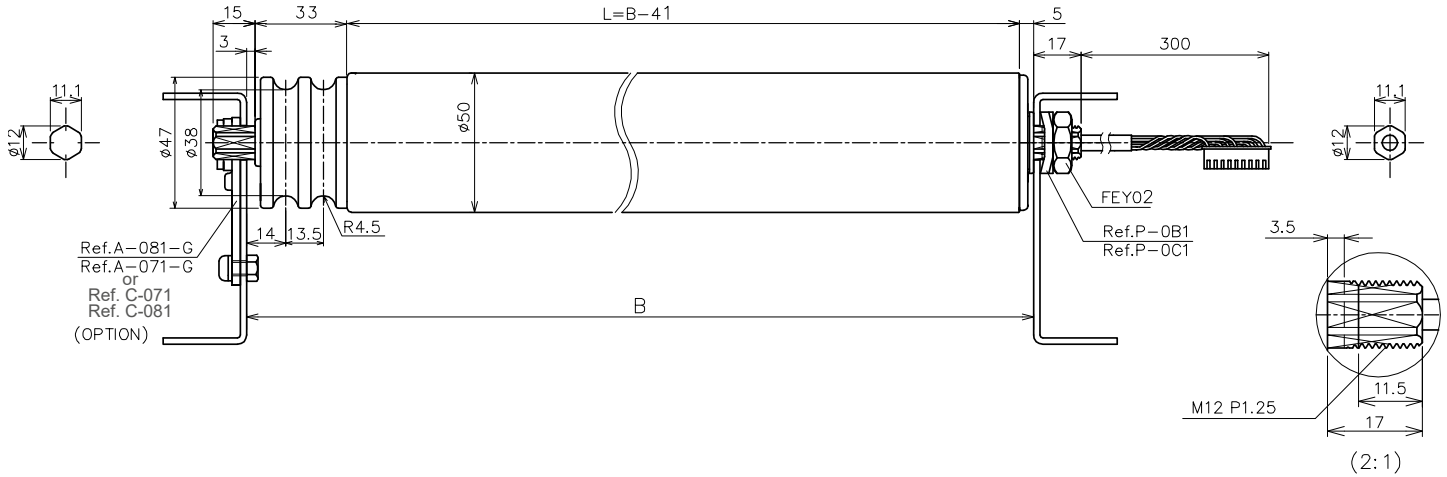

PM500FE - Hexagonal plain shaft motor side and hexagonal shaft with spring on free end

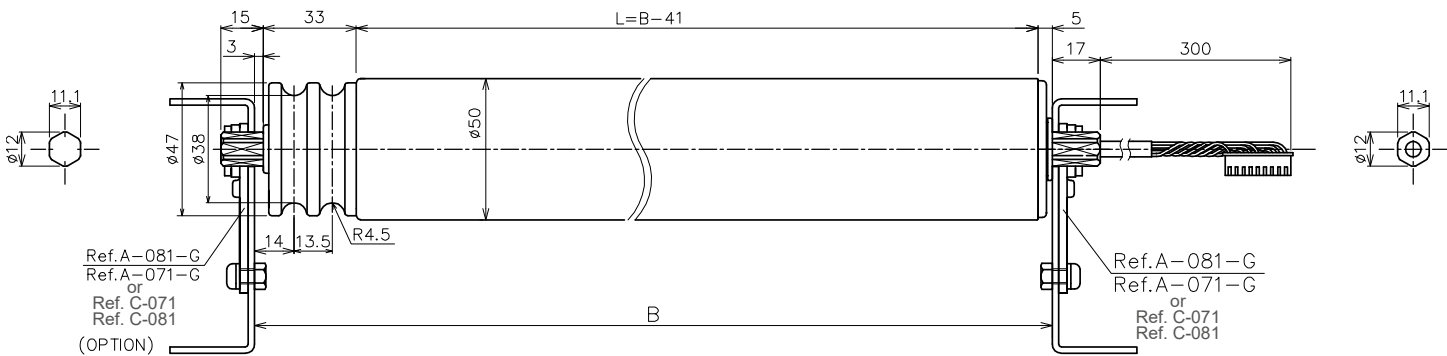

Dimensions PM500FE

Speed code	Dimension (B)	Tube length (L)
	mini ≤ B ≤ max	mini ≤ L ≤ max**
15	356 ≤ B ≤ 1241	315 ≤ L ≤ 1200
25 / 55	336 ≤ B ≤ 1241	295 ≤ L ≤ 1200
90	316 ≤ B ≤ 1241	275 ≤ L ≤ 1200

** Please consult us for tube lengths over 1200mm.

WEIGHT / STATIC LOAD / AXIAL FORCE

Tube length		300	400	500	600	700	800	900	1000	1100	1200
Weight (Kg)	15 m/min	2,8	2,9	3,1	3,2	3,4	3,6	3,7	3,9	4,1	4,2
	25m/min	2,5	2,7	2,9	3,0	3,2	3,4	3,5	3,7	3,9	4,0
	55m/min	2,6	2,7	2,9	3,1	3,2	3,4	3,6	3,7	3,9	4,0
	90m/min	2,3	2,4	2,6	2,8	2,9	3,1	3,2	3,4	3,6	3,7
Static load max (kg)		65	55	45	35	30	25	20	20	15	10
Axial force max (N)		290									

Roller with pulley for round belt - M8 threaded shaft with screw on free end

PM500FE - Hexagonal threaded shaft motor side and M8 threaded shaft with screw on free end

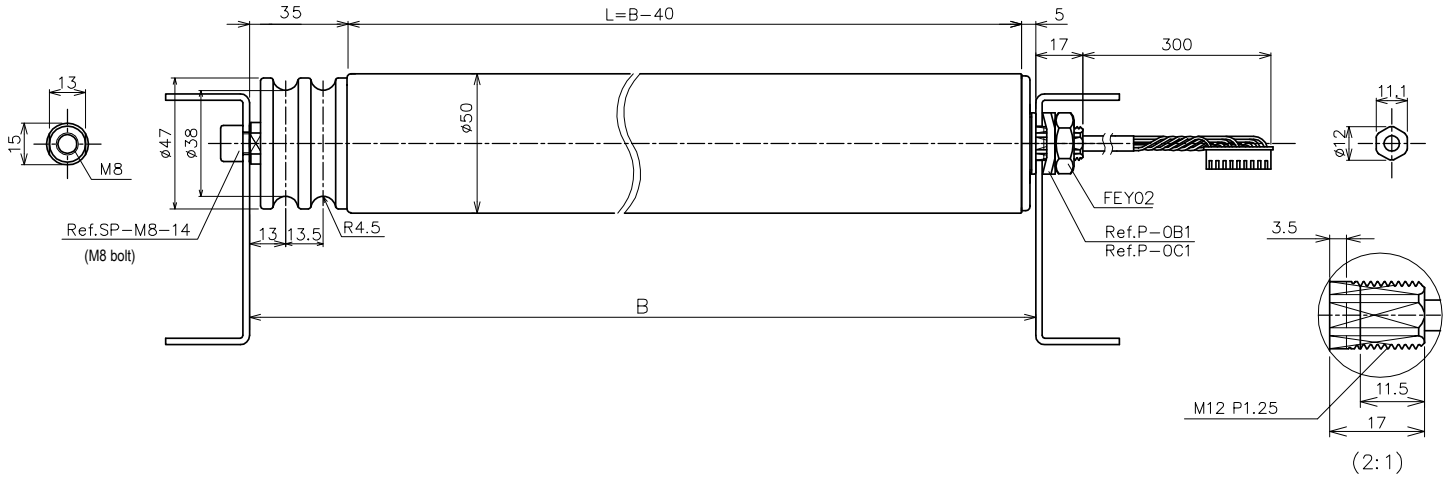

PM500FE - Hexagonal plain shaft motor side and M8 threaded shaft with screw on free end

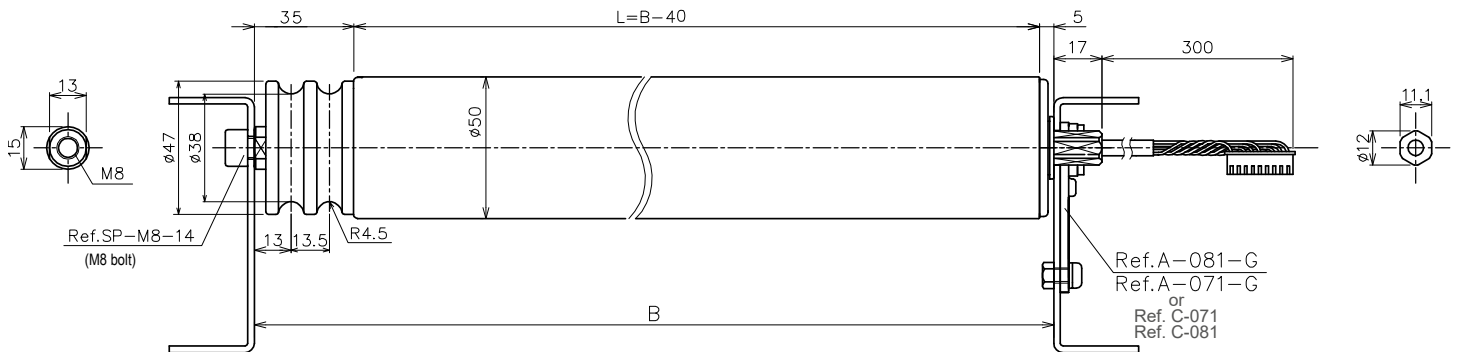

Dimensions PM500FE

Speed code	Dimension (B)	Tube length (L)
	mini ≤ B ≤ max	mini ≤ L ≤ max**
15	345 ≤ B ≤ 1240	305 ≤ L ≤ 1200
25 / 55	325 ≤ B ≤ 1240	285 ≤ L ≤ 1200
90	305 ≤ B ≤ 1240	265 ≤ L ≤ 1200

** Please consult us for tube lengths over 1200mm.

WEIGHT / STATIC LOAD / AXIAL FORCE

Tube length		300	400	500	600	700	800	900	1000	1100	1200
Weight (Kg)	15 m/min	2,8	2,9	3,1	3,2	3,4	3,6	3,7	3,9	4,1	4,2
	25m/min	2,5	2,7	2,9	3,0	3,2	3,4	3,5	3,7	3,9	4,0
	55m/min	2,6	2,7	2,9	3,1	3,2	3,4	3,6	3,7	3,9	4,0
	90m/min	2,3	2,4	2,6	2,8	2,9	3,1	3,2	3,4	3,6	3,7
Static load max (kg)		65	55	45	35	30	25	20	20	15	10
Axial force max (N)		290									

Roller without drive - Hexagonal shaft with spring on free end

PM500FE - Hexagonal threaded shaft motor side and hexagonal shaft with spring on free end

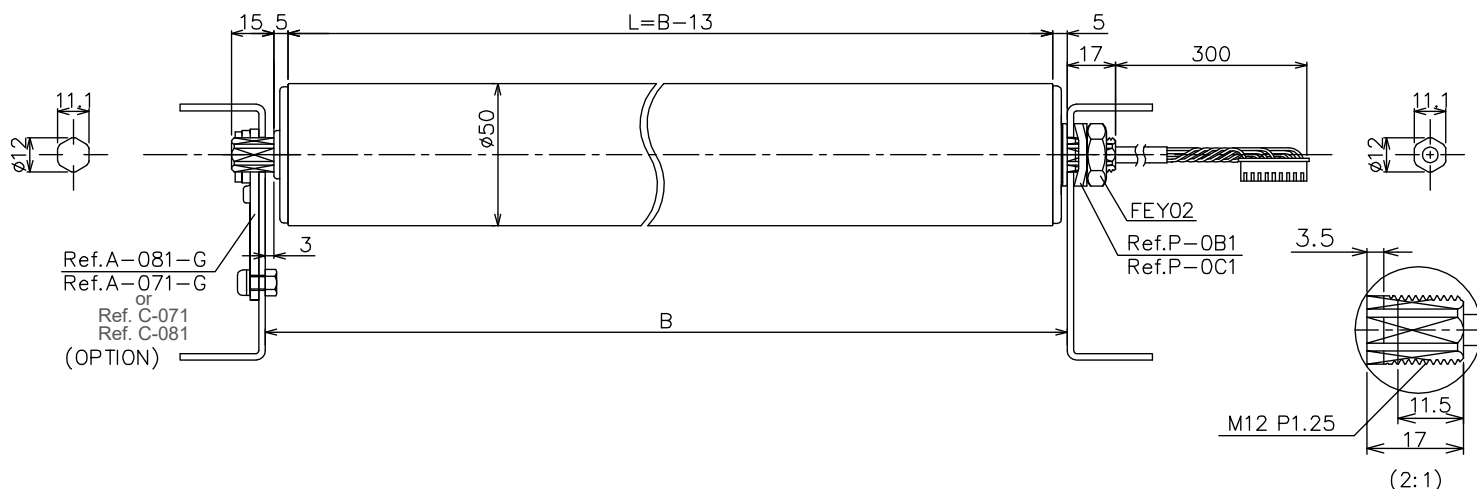

PM500FE - Hexagonal plain shaft motor side and hexagonal shaft with spring on free end

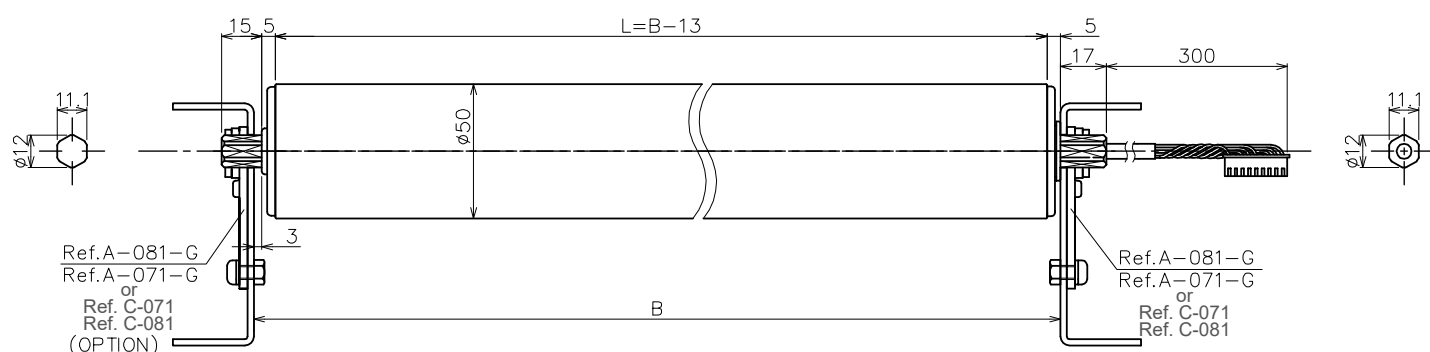

Dimensions PM500FE

Speed code	Dimension (B)	Tube length (L)
	mini ≤ B ≤ max	mini ≤ L ≤ max
15	308 ≤ B ≤ 1213	295 ≤ L ≤ 1200
25 / 55	283 ≤ B ≤ 1213	270 ≤ L ≤ 1200
90	253 ≤ B ≤ 1213	240 ≤ L ≤ 1200

** Please consult us for tube lengths over 1200mm.

WEIGHT / STATIC LOAD / AXIAL FORCE

Tube length		300	400	500	600	700	800	900	1000	1100	1200
Weight (Kg)	15 m/min	2,6	2,8	2,9	3,1	3,3	3,4	3,6	3,7	3,9	4,1
	25m/min	2,4	2,5	2,7	2,9	3,0	3,2	3,4	3,5	3,7	3,9
	55m/min	2,4	2,6	2,7	2,9	3,1	3,2	3,4	3,6	3,7	3,9
	90m/min	2,1	2,3	2,4	2,6	2,8	2,9	3,1	3,3	3,4	3,6
Static load max (kg)		65	55	45	35	30	25	20	20	15	10
Axial force max (N)		290									

Roller without drive - M8 threaded shaft with screw on free end

PM500FE - Hexagonal threaded shaft motor side and M8 threaded shaft with screw on free end

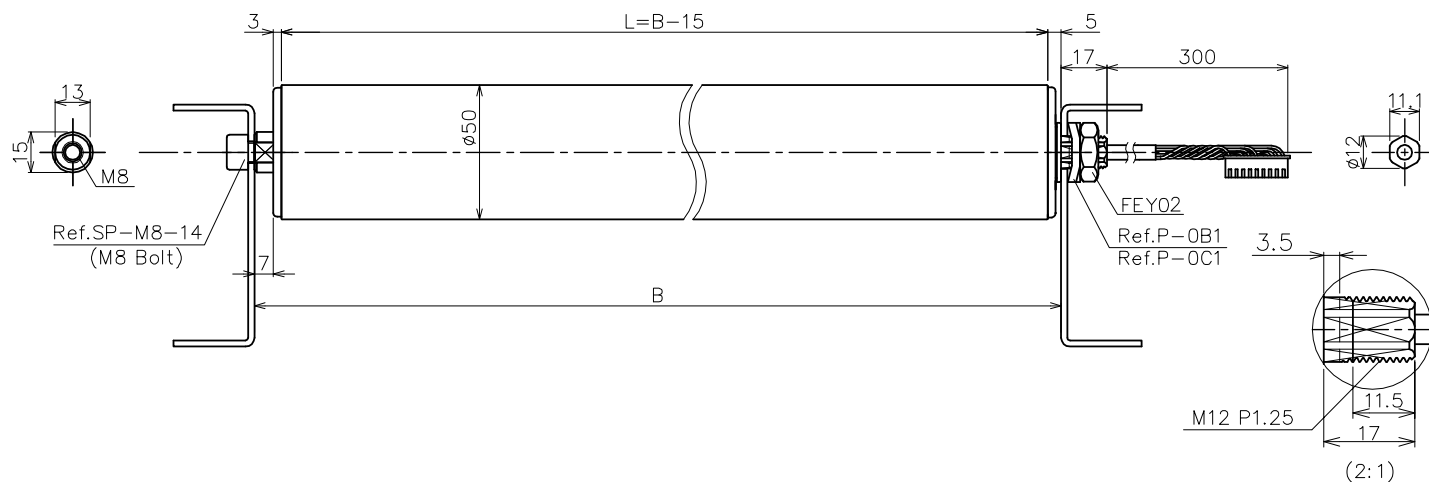

PM500FE - Hexagonal plain shaft motor side and M8 threaded shaft with screw on free end

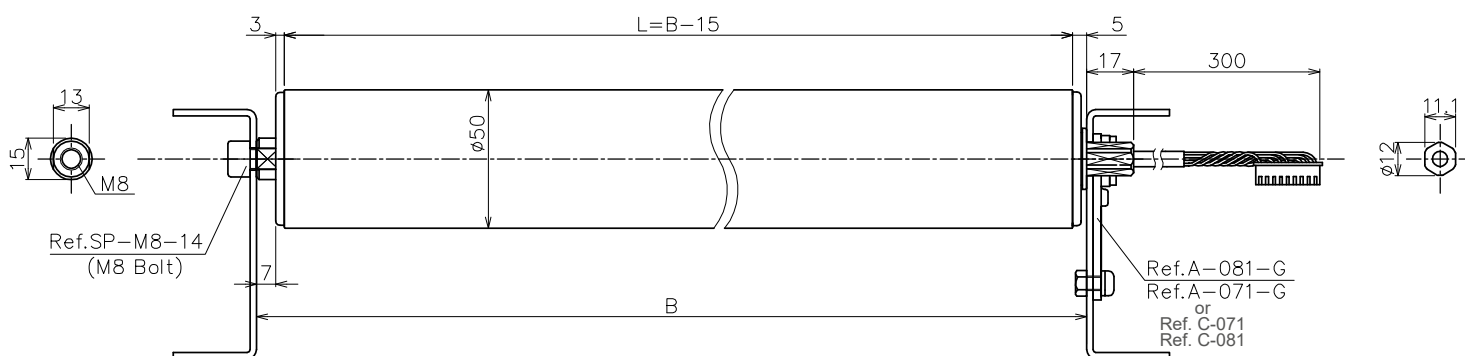

Dimensions PM500FE

Speed code	Dimension (B)	Tube length (L)
	mini ≤ B ≤ max	mini ≤ L ≤ max
15	300 ≤ B ≤ 1215	285 ≤ L ≤ 1200
25 / 55	275 ≤ B ≤ 1215	260 ≤ L ≤ 1200
90	245 ≤ B ≤ 1215	230 ≤ L ≤ 1200

** Please consult us for tube lengths over 1200mm.

WEIGHT / STATIC LOAD / AXIAL FORCE

Tube length		300	400	500	600	700	800	900	1000	1100	1200
Weight (Kg)	15 m/min	2,6	2,8	2,9	3,1	3,2	3,4	3,6	3,7	3,9	4,1
	25m/min	2,4	2,5	2,7	2,9	3,0	3,2	3,4	3,5	3,7	3,9
	55m/min	2,4	2,6	2,7	2,9	3,1	3,2	3,4	3,6	3,7	3,9
	90m/min	2,1	2,3	2,4	2,6	2,8	2,9	3,1	3,3	3,4	3,6
Static load max (kg)		65	55	45	35	30	25	20	20	15	10
Axial force max (N)		290									

6 - DIMENSIONAL CHARACTERISTICS - CURVE

Conical roller with grooved tube - Ri = 800mm

PM500FE

Hexagonal plain shaft motor side and hexagonal shaft with spring on free end

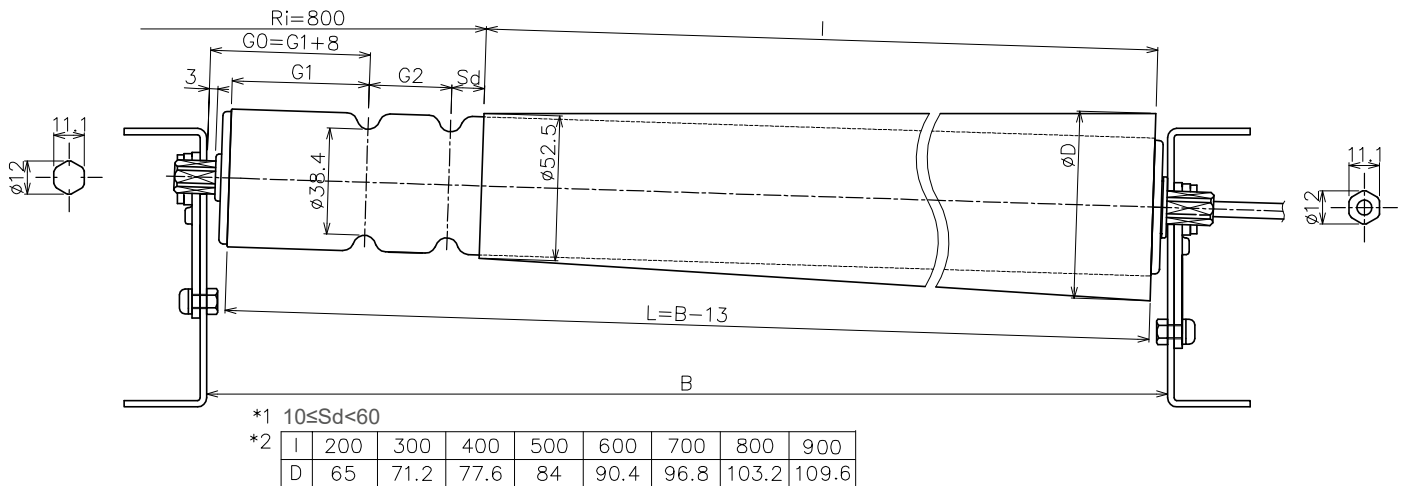

Dimensions PM500FE - Inner radius of curvature (Ri) : 800 mm

STEEL TUBE

Speed code	Dimension (B)	Tube length (L)	Grooves for steel tube Depth = 5.8mm				Tapered sleeve length (I)
	mini ≤ B ≤ max	mini ≤ L ≤ max	G0 mini	G1 mini	G2 mini	G1+G2 max	
15	283+G1+G2 ≤ B ≤ 1213	270+G1+G2 ≤ L ≤ 1200					
25/55	253+G1+G2 ≤ B ≤ 1213	240+G1+G2 ≤ L ≤ 1200	≥ 41	≥ 33	≥ 22	≤ 300	200, 300, 400, 500, 600, 700, 800, 900
90	223+G1+G2 ≤ B ≤ 1213	210+G1+G2 ≤ L ≤ 1200					

STAINLESS STEEL TUBE

Speed code	Dimension (B)	Tube length (L)	Grooves for stainless steel tube* Depth = 5.2mm				Tapered sleeve length (I)
	mini ≤ B ≤ max	mini ≤ L ≤ max	G0 mini	G1 mini	G2 mini	G1+G2 max	
15	283+G1+G2 ≤ B ≤ 1213	270+G1+G2 ≤ L ≤ 1200					
25/55	253+G1+G2 ≤ B ≤ 1213	240+G1+G2 ≤ L ≤ 1200	≥ 41	≥ 33	≥ 30	≤ 300	200, 300, 400, 500, 600, 700, 800, 900
90	223+G1+G2 ≤ B ≤ 1213	210+G1+G2 ≤ L ≤ 1200					

⚠ For a single groove G2=0.

⚠ *Stainless steel tube : For IP54 version

ADDITIONAL WEIGHT

Sleeve length (mm)	200	300	400	500	600	700	800	900
Additional weight (kg)	0,1	0,2	0,3	0,4	0,5	0,6	0,8	0,9
Static load max (kg)	10							

Conical roller with pulley for ribbed belt - Ri = 800mm

PM500FE

Hexagonal plain shaft motor side and hexagonal shaft with spring on free end

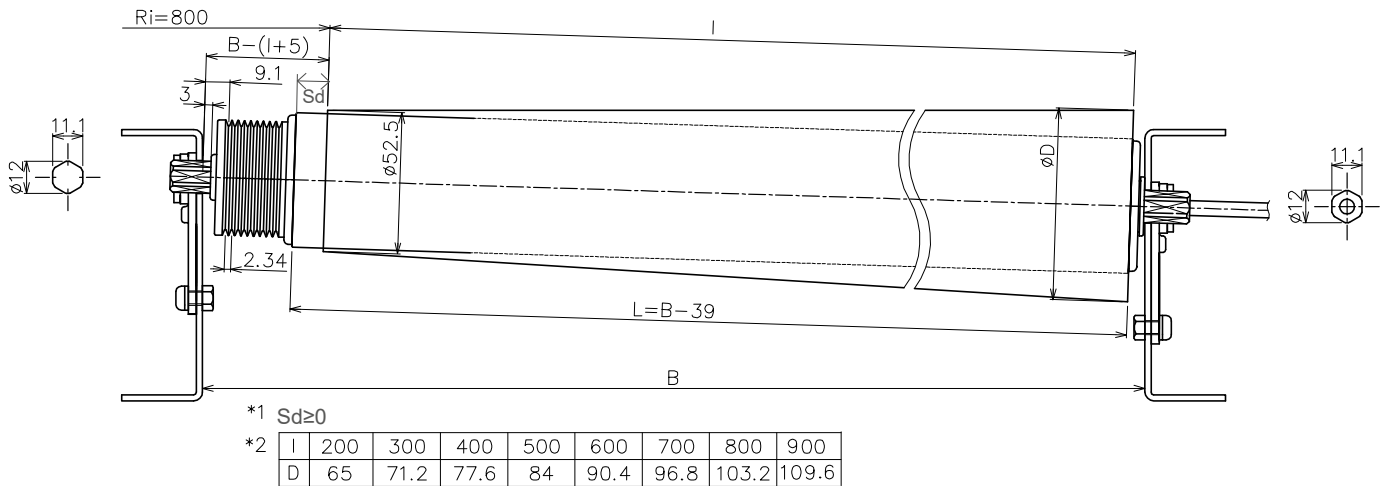

Dimensions PM500FE - Inner radius of curvature (Ri) : 800 mm

Speed code	Dimension (B)	Tube length (L)	Tapered sleeve length (l)
	mini ≤ B ≤ max	mini ≤ L ≤ max	
15	334 ≤ B ≤ 1239	295 ≤ L ≤ 1200	200, 300, 400, 500, 600, 700, 800, 900
25 / 55	309 ≤ B ≤ 1239	270 ≤ L ≤ 1200	
90	279 ≤ B ≤ 1239	240 ≤ L ≤ 1200	

ADDITIONNAL WEIGHT

Sleeve length	200	300	400	500	600	700	800	900
Additional weight (kg)	0,1	0,2	0,3	0,4	0,5	0,6	0,8	0,9
Static load max (kg) (kg)	10							

- ⚠ For the curve, it's recommended to:
- not exceed 5° angle between the rollers
 - use a 3 ribs belt to ensure stability on the pulley

Conical roller with pulley for round belt - Ri = 800mm

PM500FE

Hexagonal plain shaft motor side and hexagonal shaft with spring on free end

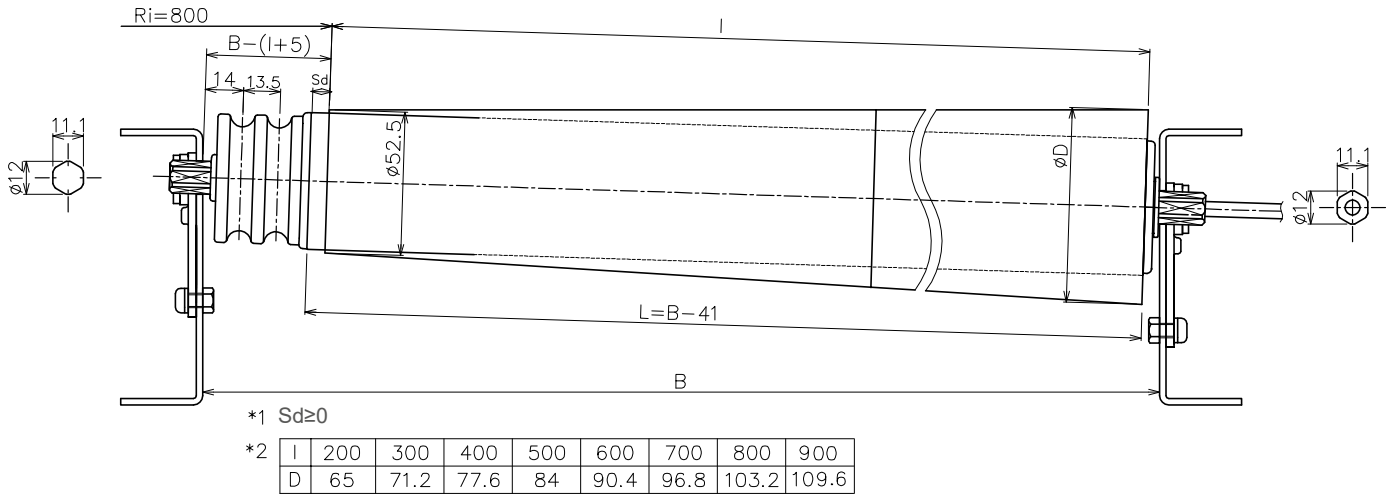

Dimensions PM500FE - Inner radius of curvature (Ri) : 800 mm

Speed code	Dimension (B)	Tube length (L)	Tapered sleeve length
	mini ≤ B ≤ max		
15	356 ≤ B ≤ 1241	315 ≤ L ≤ 1200	200, 300, 400, 500, 600, 700, 800, 900
25 / 55	336 ≤ B ≤ 1241	295 ≤ L ≤ 1200	
90	316 ≤ B ≤ 1241	275 ≤ L ≤ 1200	

ADDITIONNAL WEIGHT

Sleeve length	200	300	400	500	600	700	800	900
Additional weight (kg)	0,1	0,2	0,3	0,4	0,5	0,6	0,8	0,9
Static load max (kg)	10							

Conical roller with grooved tube - Ri = 850mm

PM500FE

Hexagonal plain shaft motor side and hexagonal shaft with spring on free end

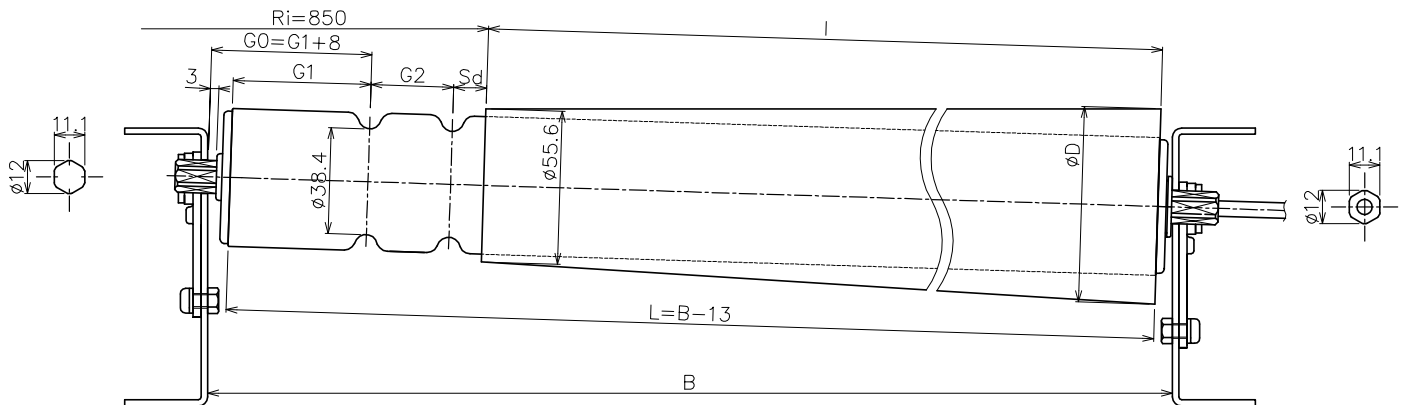

*1 $10 \leq Sd < 60$

*2	I	150	250	350	450	550	650	750	850
	D	65	71.2	77.6	84	90.4	96.8	103.2	109.6

Dimensions PM500FE - Inner radius of curvature (Ri) : 850 mm

STEEL TUBE

Speed code	Dimension (B)	Tube length (L)	Grooves for steel tube Depth = 5.8mm				Tapered sleeve length
	mini ≤ B ≤ max	mini ≤ L ≤ max	G0 mini	G1 mini	G2 mini	G1+G2 max	
15	283+G1+G2 ≤ B ≤ 1213	270+G1+G2 ≤ L ≤ 1200					150, 250, 350, 450, 550, 650, 750, 850
25/55	253+G1+G2 ≤ B ≤ 1213	240+G1+G2 ≤ L ≤ 1200	≥ 41	≥ 33	≥ 22	≤ 300	
90	223+G1+G2 ≤ B ≤ 1213	210+G1+G2 ≤ L ≤ 1200					

STAINLESS STEEL TUBE

Speed code	Dimension (B)	Tube length (L)	Grooves for stainless steel tube* Depth = 5.2mm				Tapered sleeve length
	mini ≤ B ≤ max	mini ≤ L ≤ max	G0 mini	G1 mini	G2 mini	G1+G2 max	
15	283+G1+G2 ≤ B ≤ 1213	270+G1+G2 ≤ L ≤ 1200					150, 250, 350, 450, 550, 650, 750, 850
25/55	253+G1+G2 ≤ B ≤ 1213	240+G1+G2 ≤ L ≤ 1200	≥ 41	≥ 33	≥ 30	≤ 300	
90	223+G1+G2 ≤ B ≤ 1213	210+G1+G2 ≤ L ≤ 1200					

⚠ For a single groove G2=0.

⚠ *Stainless steel tube : For IP54 version

ADDITIONAL WEIGHT

Sleeve length	150	250	350	450	550	650	750	850
Additional weight (kg)	0,1	0,2	0,2	0,3	0,5	0,6	0,7	0,9
Static load max (kg)	10							

Conical roller with pulley for ribbed belt - Ri = 850mm

PM500FE

Hexagonal plain shaft motor side and hexagonal shaft with spring on free end

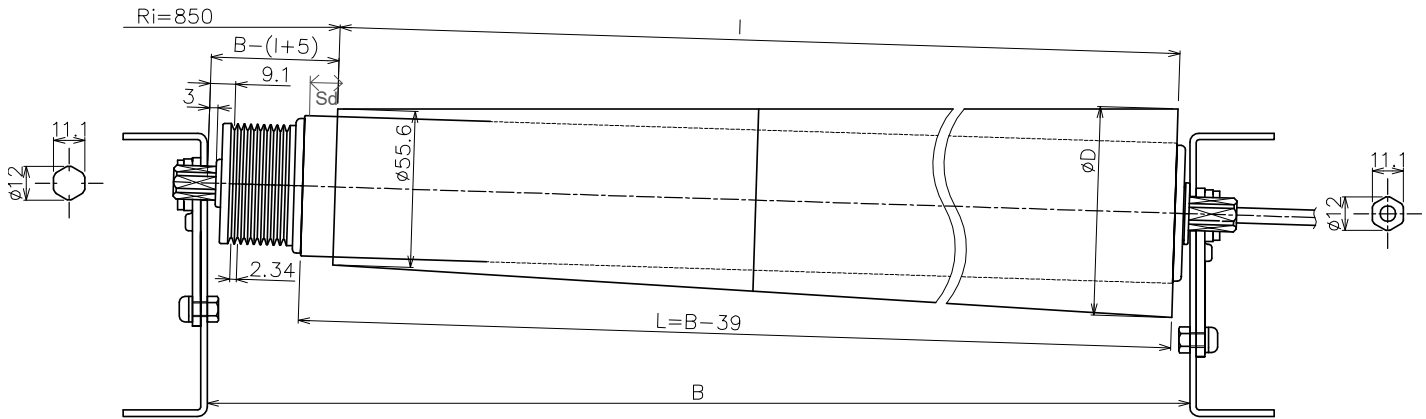

*1 Sd ≥ 0

*2	I	150	250	350	450	550	650	750	850
	D	65	71.2	77.6	84	90.4	96.8	103.2	109.6

Dimensions PM500FE - Inner radius of curvature (Ri) : 850 mm

Speed code	Dimension (B)	Tube length (L)	Tapered sleeve length
	mini ≤ B ≤ max	mini ≤ L ≤ max	
15	334 ≤ B ≤ 1239	295 ≤ L ≤ 1200	150, 250, 350, 450, 550, 650, 750, 850
25 / 55	309 ≤ B ≤ 1239	270 ≤ L ≤ 1200	
90	279 ≤ B ≤ 1239	240 ≤ L ≤ 1200	

ADDITIONAL WEIGHT

Sleeve length	150	250	350	450	550	650	750	850
Additional weight (kg)	0,1	0,2	0,2	0,3	0,5	0,6	0,7	0,8
Static load max (kg)	10							

- ⚠ For the curve, it's recommended to:
- not exceed 5° angle between the rollers
 - use a 3 ribs belt to ensure stability on the pulley

7 - DIMENSIONAL CHARACTERISTICS - MISCELLANEOUS

PVC sleeve

For conveying a fragile load or to lower the sound level.
Sleeved by compressed air.
Anti-static option.

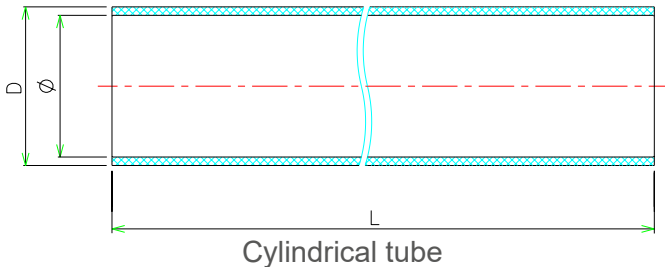

Thickness (mm)	L (mm)	Ø (mm)	D (mm) (±1mm)	Hardness
2	≤1200	50	54	~68 shore A
3			56	

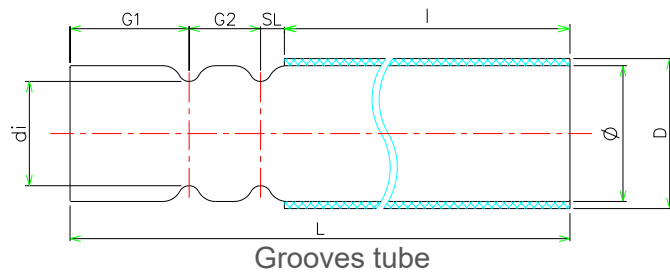

Thickness (mm)	L (mm)	Ø (mm)	D (mm) (±1mm)	SL (mm)
2	≤1200	50	54	10
3			56	

Coated in natural rubber, nitrile rubber and polyurethane

Material	Characteristics	Hardness (ShA)	Thickness (mm)
Natural rubber	It improves the adherence of the products conveyed and reduces noise. Do not use in contact with hydrocarbon, oil or grease.	60~65	3
Nitrile rubber			
Polyurethane	High resistance to abrasion, tearing and oil.	90	

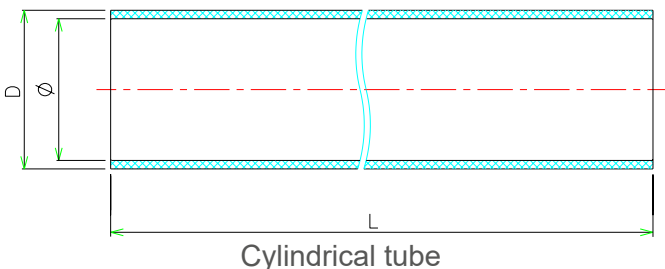

L (mm)	Ø (mm)	D (mm)
≤1000	50	56

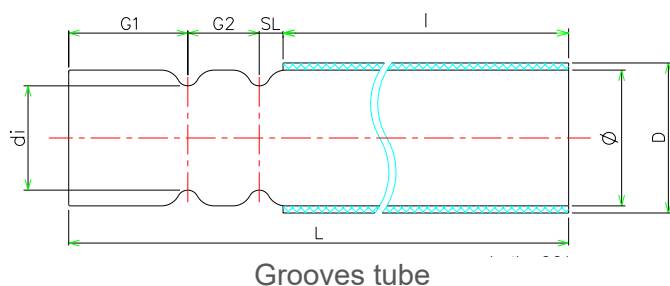

L (mm)	Ø (mm)	D (mm)	SL (mm)
≤1000	50	56	10

8 - BELT CONVEYOR APPLICATION

Condition of use and recommendation

The PM500FE motorized roller allows to create a conveyor with very small dimensions to convey light loads, provided that the hereafter conditions are followed :

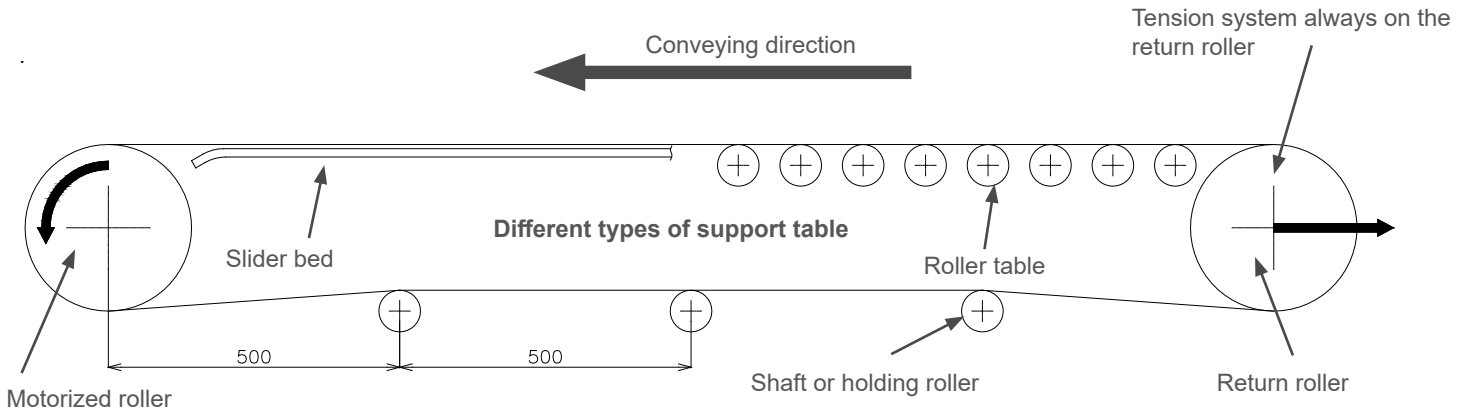

- Belt thickness recommended $\leq 1\text{mm}$
- Belt weight $\leq 1,4\text{kg/m}^2$
- Belt tension to be applied: $10\text{N} \leq T \leq 200\text{N}$

$T = (\text{Weight of total load on the conveyor} + \text{Weight of belt}) \times \mu \times 1,25 \times 9,81$

$\mu = \text{Coefficient of friction between support table and belt } (0,2 \leq \mu \leq 0,5)$

- Conveyor max dimensions :
 - Length (L) $\leq 2000\text{mm}$ (depending on speed code)
 - Width (W) $\leq 800\text{mm}$ (depending on speed code)
- Mount the motorized roller downstream of the conveying direction and the return roller upstream.

⚠ The above data for belt conveyor applications are provided for information only and cannot be guaranteed. We recommend testing applications before starting operations. KT series MDR is recommended for belt conveyors.

Structure

To resist to the belt tension, reinforced endcaps, with two precision ball bearings are mounted on the roller.

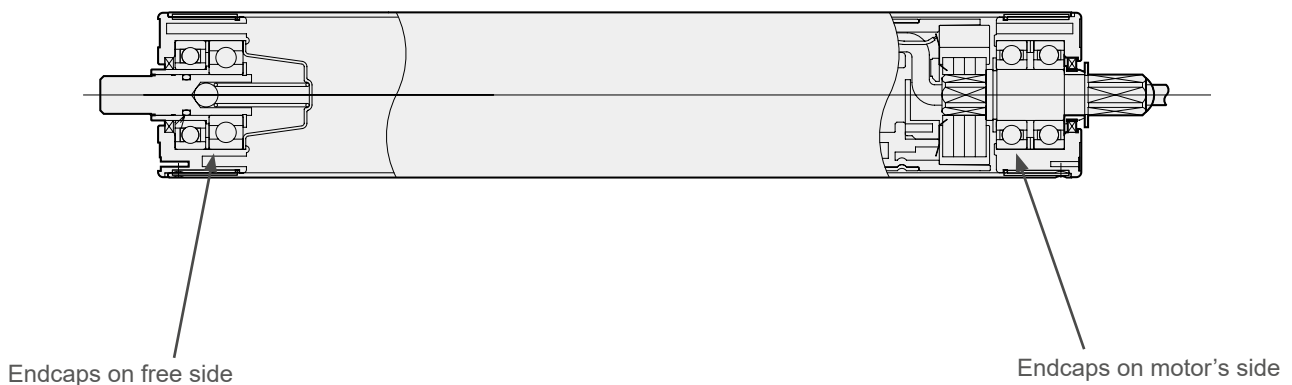

Transfer capacity

SPEED CODE 15

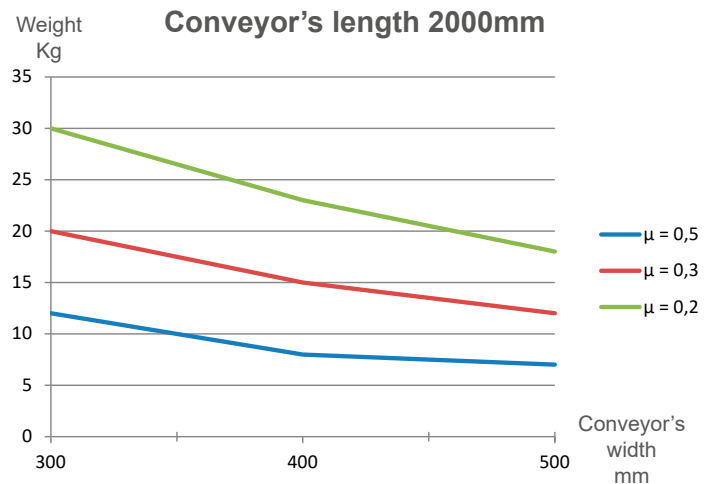
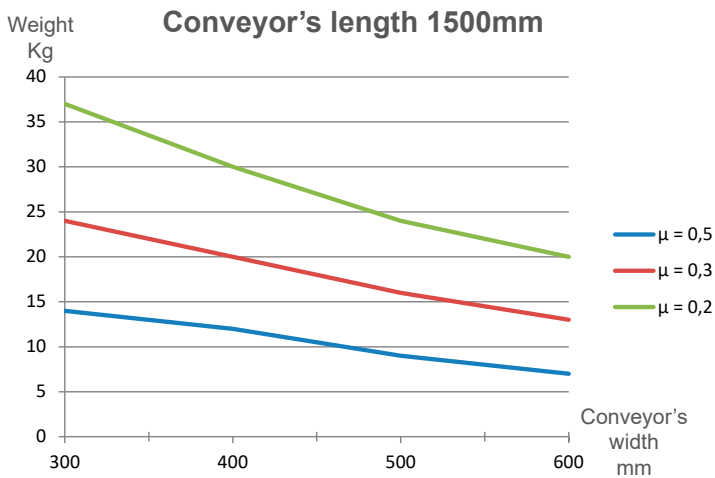
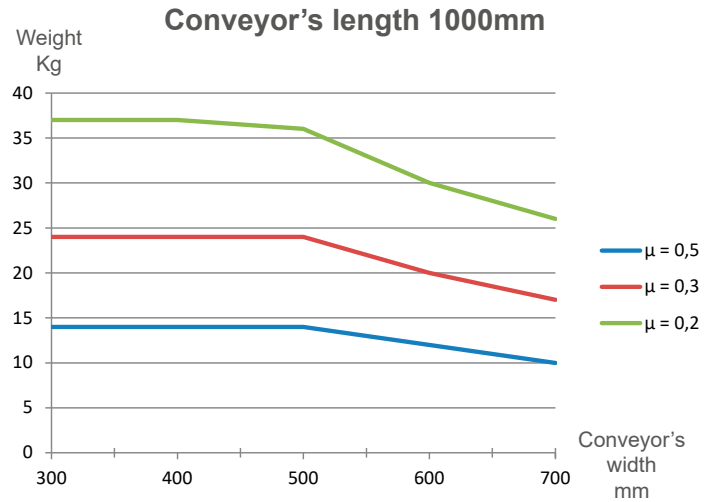
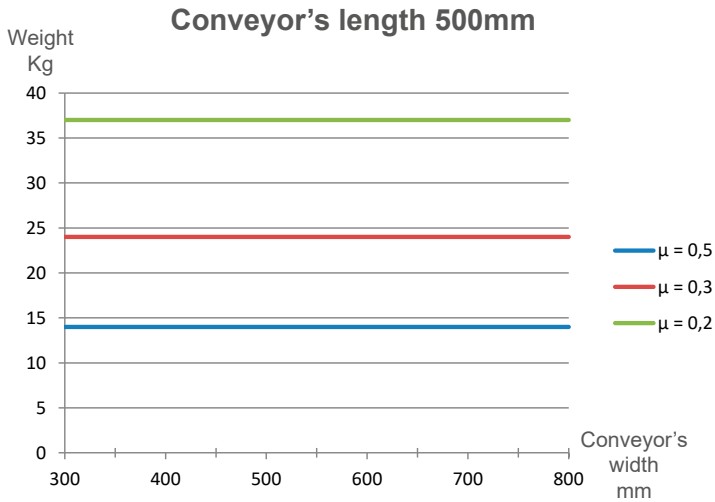

• Operation:

- Intermittent : Minimum duty cycle= 2s ON / 2s OFF
ED = ON/(ON+OFF) ≤ 50%
900 starts/H max
- Continuous: 100%

• Belt performance : 70%

These curves are given as a guide. Transfer capacity depends on the nature and quality of the transported load, the belt tension, the quality of the bearings, the nature of the sleeves, the ambient temperature...

SPEED CODE 25

Conveyor's length 500mm

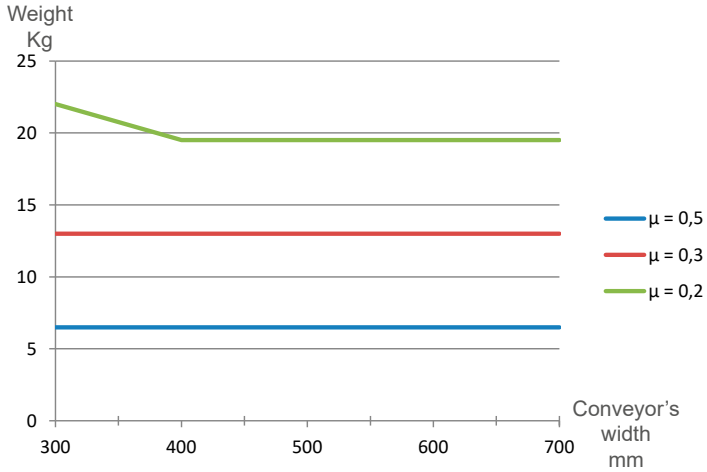

Conveyor's length 1000mm

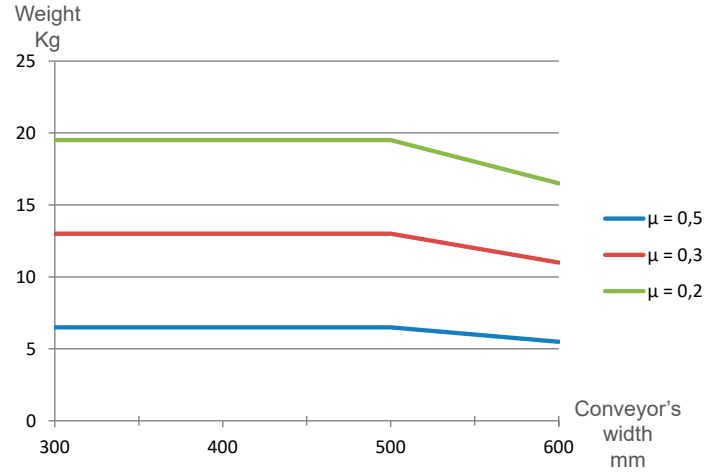

Conveyor's length 1500mm

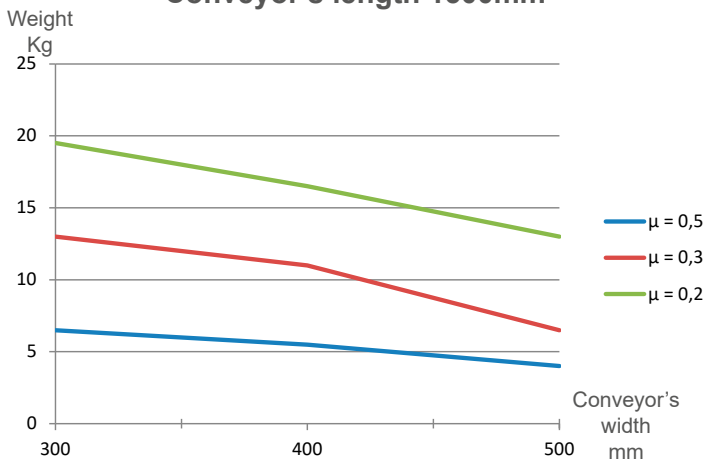

Conveyor's length 2000mm

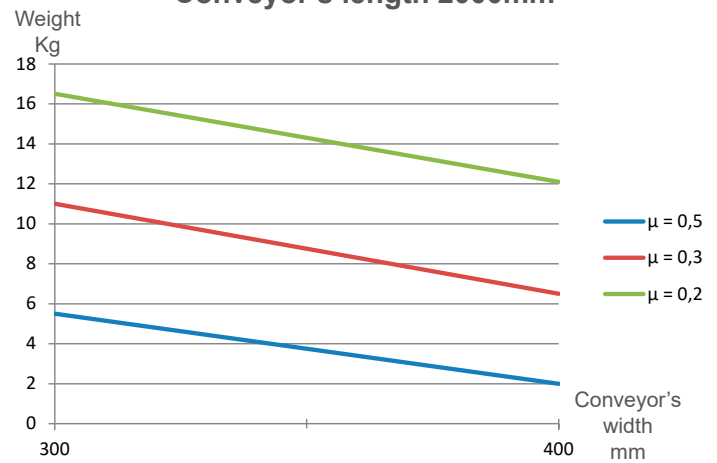

• Operation:

- Intermittent : Minimum duty cycle= 2s ON / 2s OFF
ED = ON/(ON+OFF) ≤ 50%
900 starts/H max

- Continuous: 100%

• Belt performance : 70%

These curves are given as a guide. Transfer capacity depends on the nature and quality of the transported load, the belt tension, the quality of the bearings, the nature of the sleeves, the ambient temperature...

SPEED CODE 55

Conveyor's length 500mm

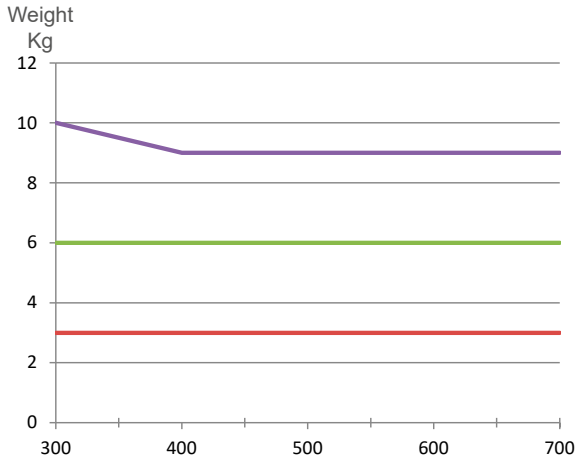

Conveyor's length 1000mm

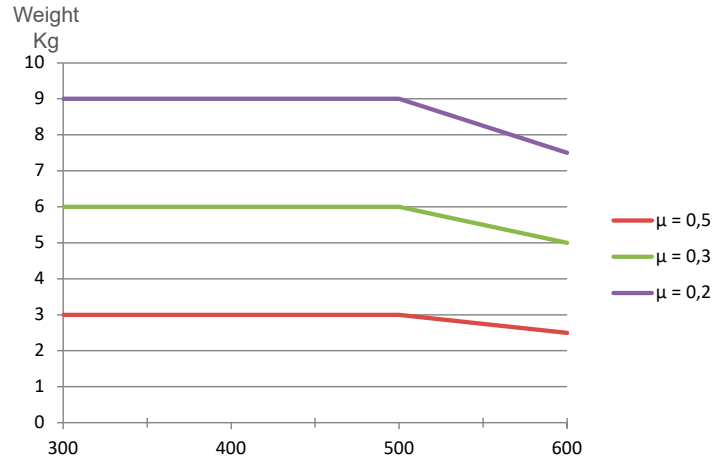

Conveyor's length 1500mm

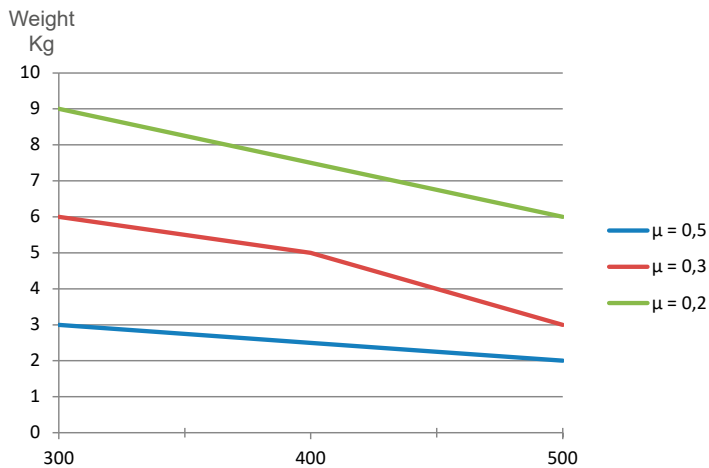

Conveyor's length 2000mm

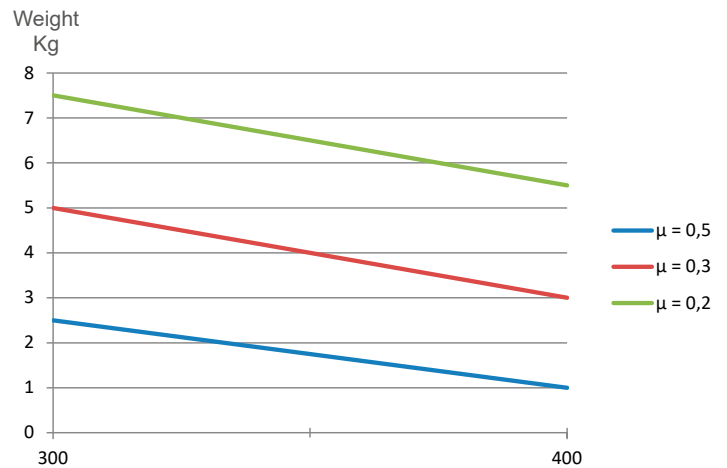

• Operation:

- Intermittent : Minimum duty cycle= 2s ON / 2s OFF
ED = ON/(ON+OFF)≤50%
900 starts/H max
- Continuous: 100%

• Belt performance : 70%

These curves are given as a guide. Transfer capacity depends on the nature and quality of the transported load, the belt tension, the quality of the bearings, the nature of the sleeves, the ambient temperature...

Dimensional characteristics and weight

Hexagonal plain shaft on motor side and hexagonal shaft with spring on free end

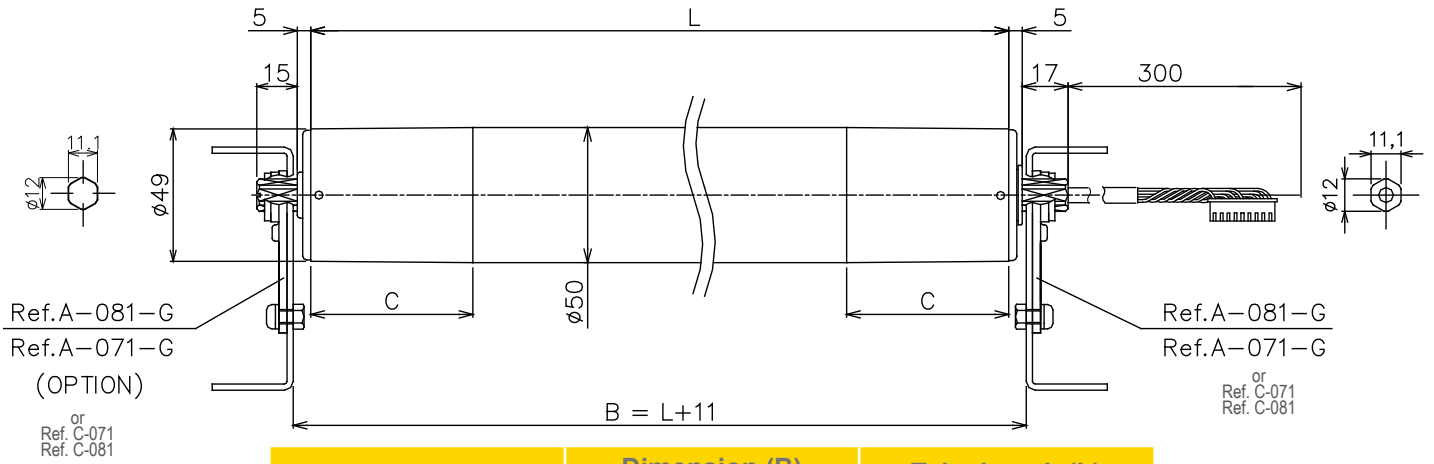

Speed code	Dimension (B)	Tube length (L)
	mini ≤ B ≤ max	mini ≤ L ≤ max
15	311 ≤ B ≤ 1011	300 ≤ L ≤ 1000
25 / 55	286 ≤ B ≤ 1011	275 ≤ L ≤ 1000

Hexagonal plain shaft on motor side and hexagonal shaft fixed on free end

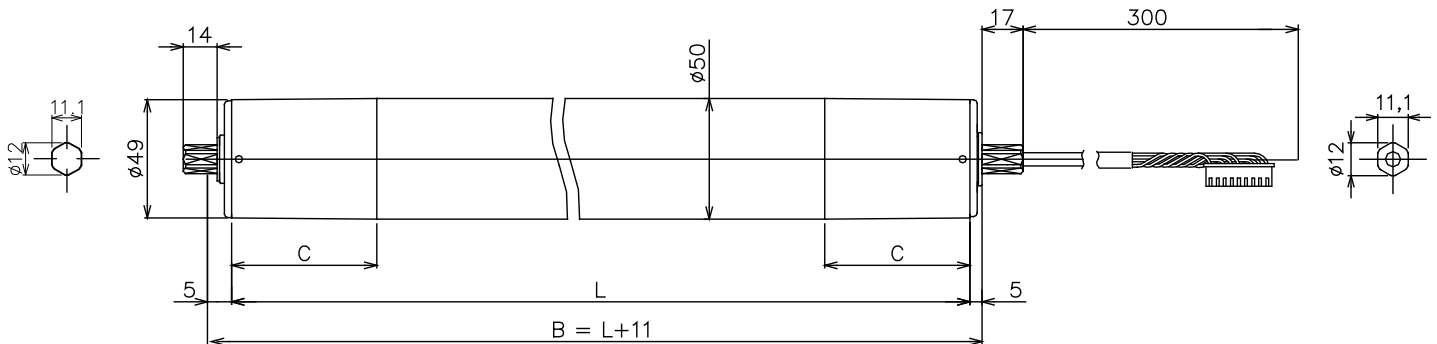

Speed code	Dimension (B)	Tube length (L)
	mini ≤ B ≤ max	mini ≤ L ≤ max
15	291 ≤ B ≤ 1011	280 ≤ L ≤ 1000
25 / 55	271 ≤ B ≤ 1011	260 ≤ L ≤ 1000

WEIGHT / STATIC LOAD / AXIAL FORCE

Tube length		300	400	500	600	700	800	1000
Weight (Kg)	15 m/min	2,7	2,9	3,0	3,2	3,4	3,5	3,7
	25 m/min	2,5	2,7	2,8	3,0	3,2	3,3	3,5
	55 m/min	2,5	2,7	2,9	3,0	3,2	3,4	3,6
Static max load (kg)		65	55	45	35	30	25	20
Axial force max (N)		290						

Tube specification

Various machining, coating and sleeves are available to insure a proper centering and a good adherence.

Tube machined crowned, zinc coated or stainless steel

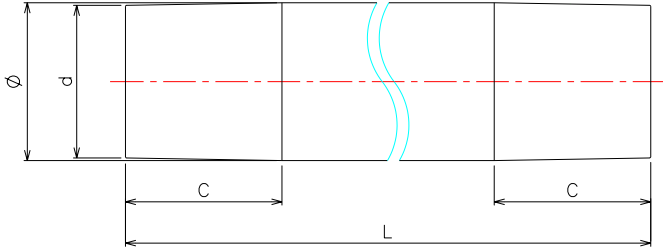

L (mm)	C (mm)	Ø (mm)	d (mm)
<600	60	50	49
600≤1000	120		

Tube machined crowned with natural rubber coating / polyurethane, in steel or stainless steel. 3mm Thickness

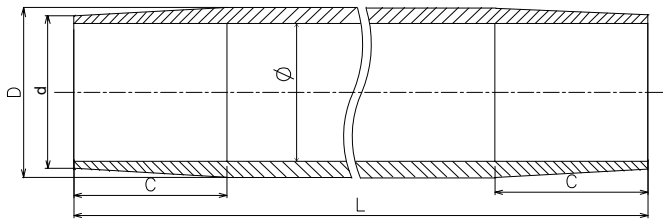

L (mm)	C (mm)	Ø (mm)	d (mm)	D (mm)
<600	60	50	55	56
600≤1000	120			

Tube with centering sleeve, zinc coated or stainless steel.

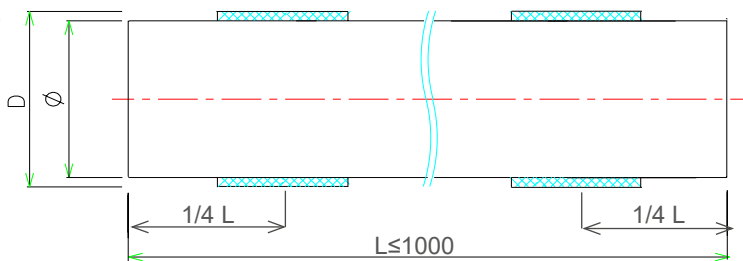
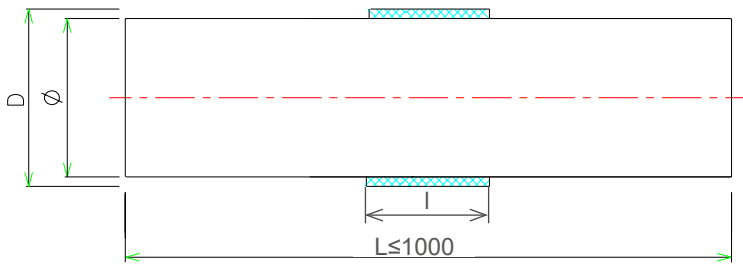

Thickness (mm)	L (mm)	Ø (mm)	D (mm)	l (mm)
3	≤1000	50	52	50

9 - MOUNTING ON THE FRAMES

Mounting plate for plain 11.1 mm hexagonal shaft - FLAT ON TOP

Conveyor with hole $\varnothing 12,3\text{mm}$

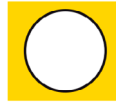

or hexagonal 11,2mm

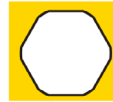

Reference	Plate
	A-071-G

! Tightening torque
*1 - 6-10 Nm
*2 - 3.5 Nm

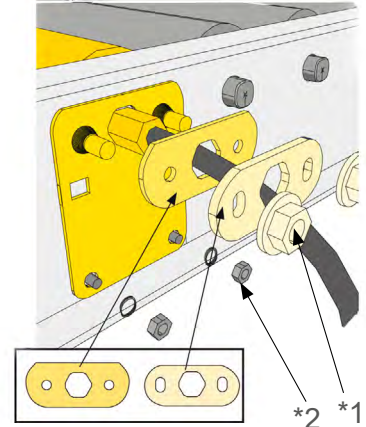

Reference	Plate
	C-071

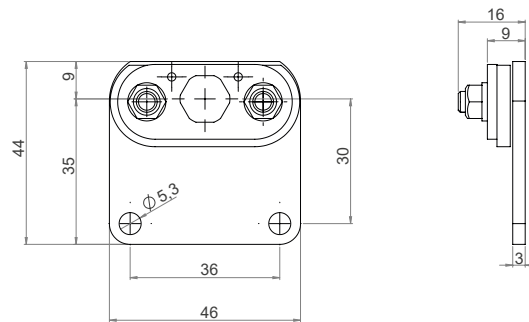
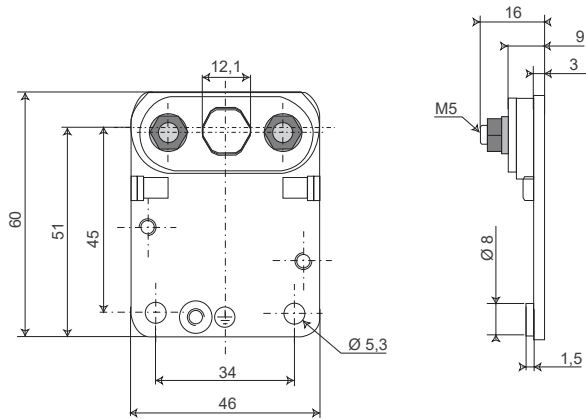

Mounting plate for plain 11.1 mm hexagonal shaft - ANGLE ON TOP

Conveyor with hole $\varnothing 12,3\text{mm}$



or hexagonal 11,2mm



Reference	Plate
	A-081-G

! Tightening torque
*1 - 6-10 Nm
*2 - 3.5 Nm

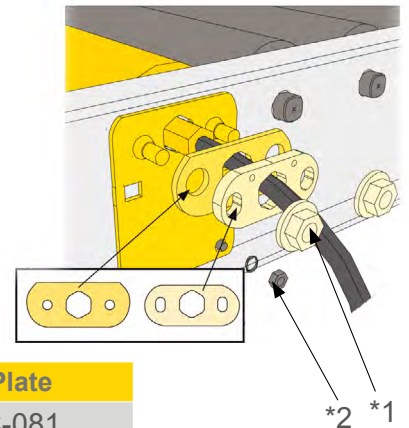

Reference	Plate
	C-081

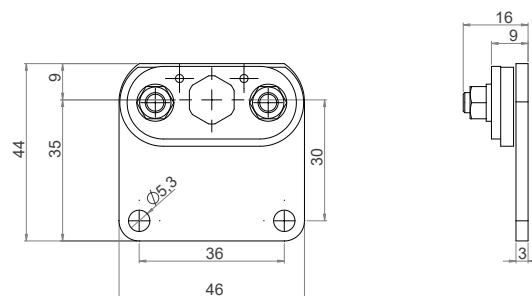
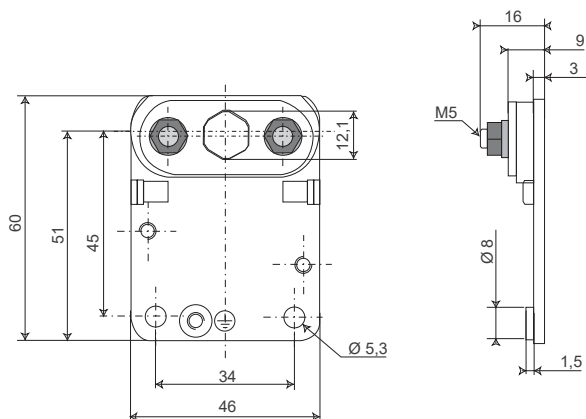

Mounting plate for threaded hexagonal shaft - FLAT ON TOP

Conveyor with hole $\varnothing 12,3\text{mm}$

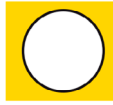

or hexagonal 11,2mm

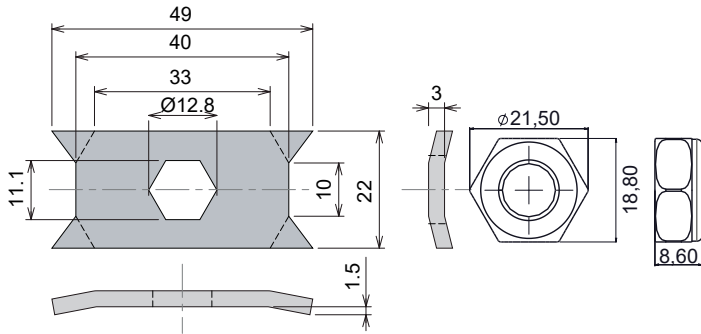
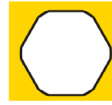

Reference	Claw plate	Washer	Nut
AM-FE-F	P-0B1	FSY02	FEY-02

! Tightening torque : 30 Nm $\pm 10\%$

Mounting plate for threaded hexagonal shaft - ANGLE ON TOP

Conveyor with hole $\varnothing 12,3\text{mm}$

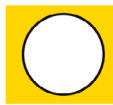

or hexagonal 11,2mm

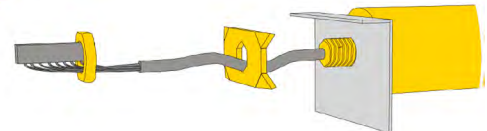
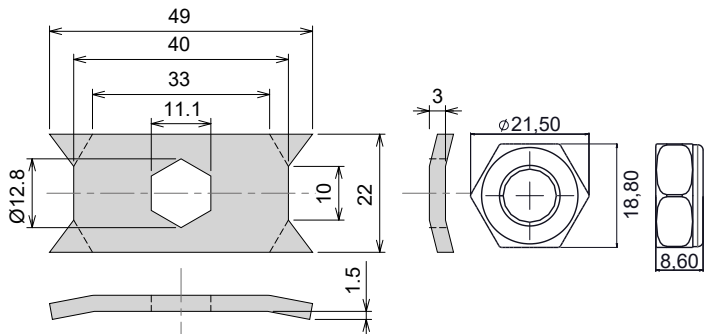

Reference	Claw plate	Washer	Nut
AM-FE-A	P-0C1	FSY02	FEY-02

! Tightening torque : 30 Nm $\pm 10\%$

M8 threaded fixed shaft

Conveyor with holes $\varnothing 8,4\text{mm}$



$\varnothing 8,4\text{ mm}$

! Tightening torque : 30 Nm $\pm 10\%$

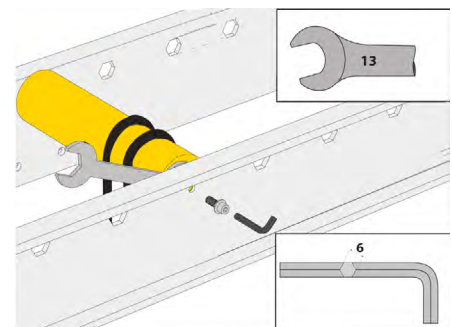

Reference	Bolt
	SP-M8-14

▶ 10 - WIRING

⚠ Motor cable is designed for fixed installation. Prevent any repetitive flexing, even with an additional guiding device.

■ With CBM-105 circuit board

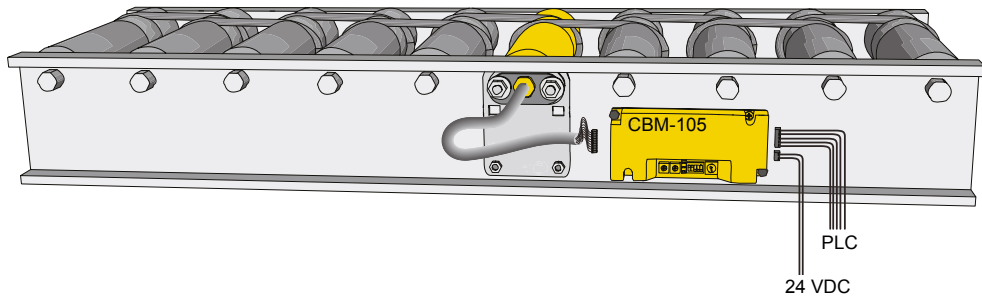

The circuit board controls and protects the brushless motorized roller.

■ With HB510 circuit board

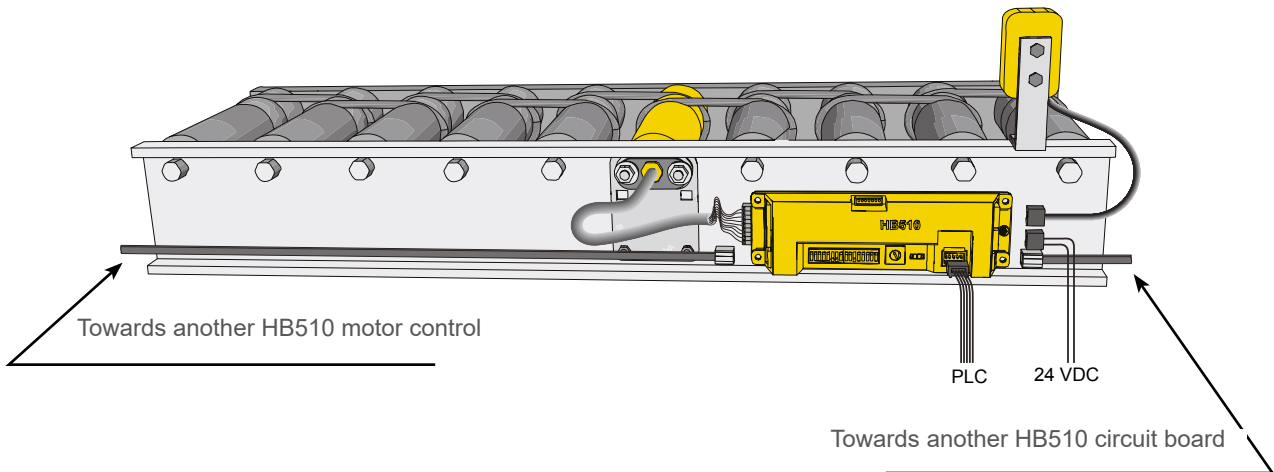

The circuit board controls the motorized roller and manages the zones to ensure ZPA (zero pressure accumulation)

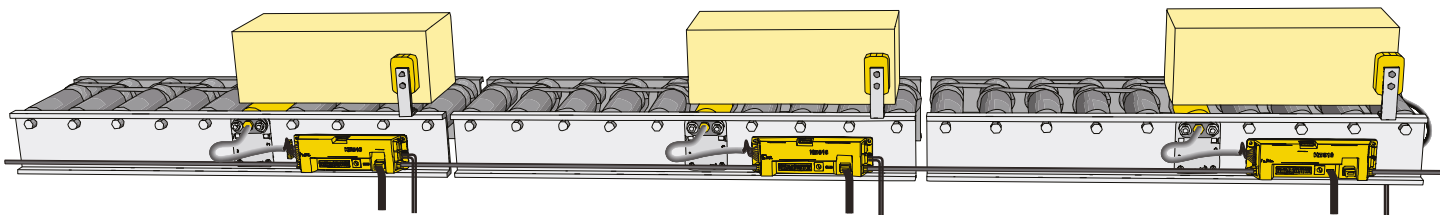

▶ 11 - ACCESSORIES

■ Ribbed belt

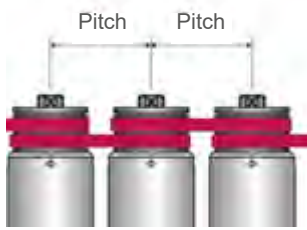

Pitch between the rollers (mm) For pulley Ø43mm	Number of teeth	
	2	3
53-56	Ref. 2PJ246-43	Ref. 3PJ246-43
60-63	Ref. 2PJ256-43	Ref. 3PJ256-43
64-65	Ref. 2PJ265-43	Ref. 3PJ265-43
66-67	Ref. 2PJ270-43	Ref. 3PJ270-43
71-72	Ref. 2PJ282-43	Ref. 3PJ282-43
73-75	Ref. 2PJ286-43	Ref. 3PJ286-43
76-78	Ref. 2PJ290-43	Ref. 3PJ290-43
80-84	Ref. 2PJ302-43	Ref. 3PJ302-43
87-91	Ref. 2PJ314-43	Ref. 3PJ314-43
92-95	Ref. 2PJ316-43	Ref. 3PJ316-43
97-101	Ref. 2PJ336-43	Ref. 3PJ336-43
103-107	Ref. 2PJ346-43	Ref. 3PJ346-43
115-118	Ref. 2PJ372-43	-
119-121	Ref. 2PJ376-43	Ref. 3PJ376-43
123-128	Ref. 2PJ388-43	Ref. 3PJ388-43
129-134	-	Ref. 3PJ416-43
142-147	-	Ref. 3PJ436-43
150-156	Ref. 2PJ442-43	Ref. 3PJ442-43
157-161	-	Ref. 3PJ456-43
170-176	-	Ref. 3PJ486-43
196-202	-	Ref. 3PJ536-43
208-215	-	Ref. 3PJ570-43

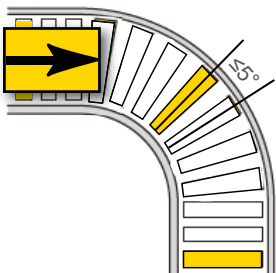

⚠ For the curve, it's recommended to:
 - not exceed 5° angle between the rollers
 - use a 3 ribs belt to ensure stability on the pulley

⚠ Do not use in the presence of:
 - Projection, oil mist
 - Projection, fog, water vapor at all times
 - Abrasive dust such as sand, etc...

■ Extension cables

For PM500FE and CBM-105 / HB510 - Male / Female - 9 pins

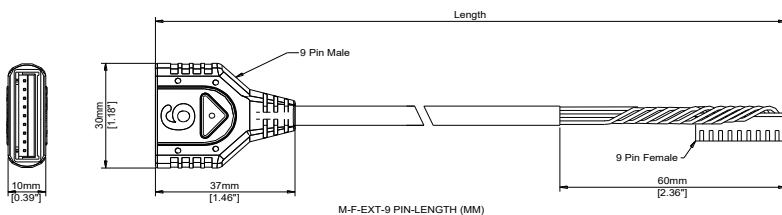

Length	Part number of the extension cable
1200mm	ACE-CBM-B1200
2700mm	ACE-CBM-B2700

- Total length of cable including cable on MDR must not be longer than 3000mm.
- Do not use multiple extension cables per MDR.

Rounded belts

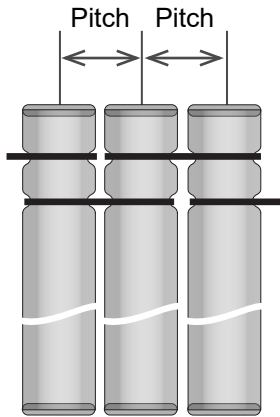

Pitch between the rollers	Belt reference
75mm	POLYCORD-R5-256
100mm	POLYCORD-R5-302

- Belt diameter : 5mm
- Belt tension : 8%
- Material: Thermoplastic polyurethane (TPU)

For grooves with an inner diameter of 38.4 mm

24 VDC power supply



Reference	Input	Output	Power	Start-up boost
CT-10-241	380~480V 3 ph	24V-10A	240W	120%
QT-20-241		24V-20A	480W	150%
QT-40-241		24V-40A	960W	150%

- Very weak inrush current.
- Accepts excess current of 120 to 150% at startup (according to model)

24 VDC distribution connector

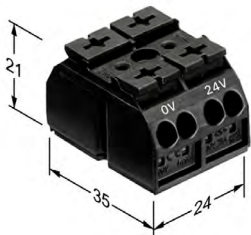

- 32A max
- 2 poles with markings «24V / OV»
- 4 connectors per pole
- Cable 0.5 - 4.00mm (AWG.....)
- Fixed with M3 bolt or screw

Reference	Connector
	PD-2P

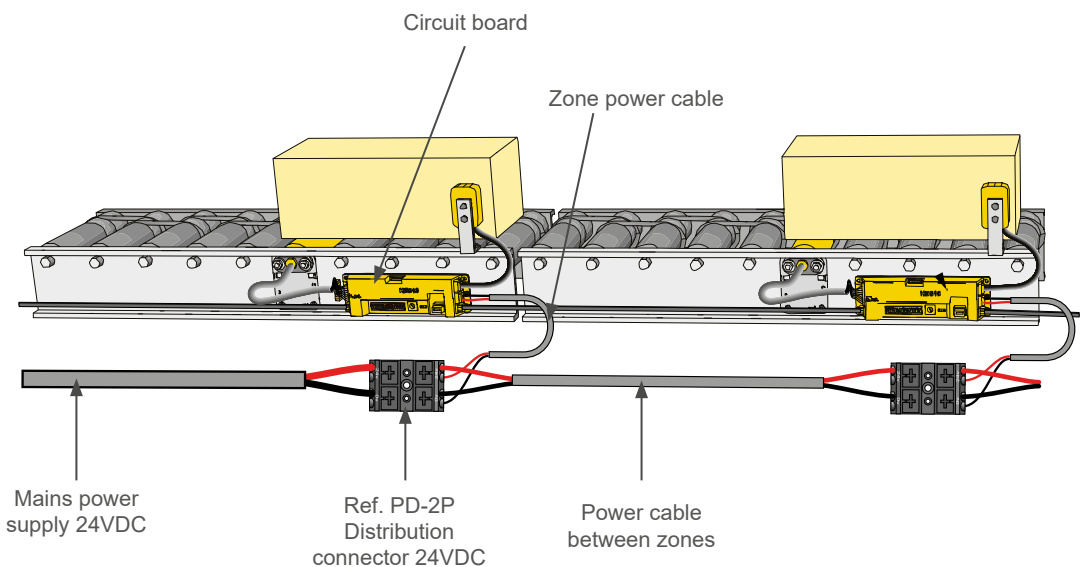

12 - PRODUCT IDENTIFICATION

Round label

Power Moller® rollers come with a round label affixed to the endcaps at the motor end. The following information are shown on the label :

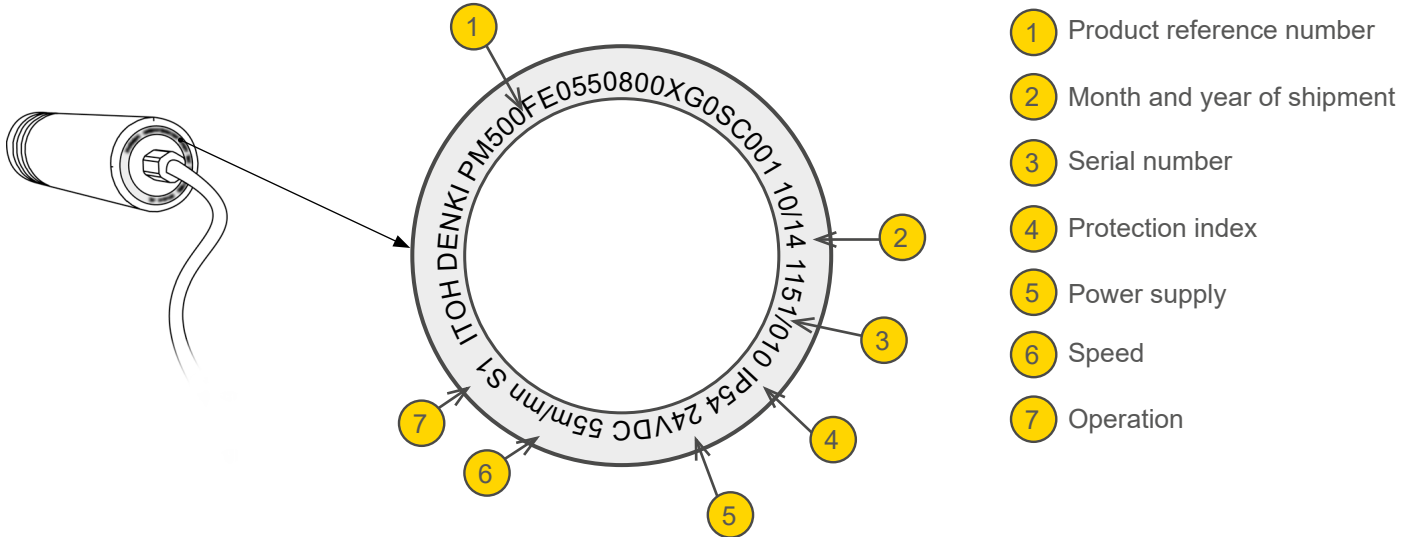

Square label

Power Moller® rollers come with a square self-adhesive label that must be affixed to the conveyor, to facilitate any future maintenance. The following information are shown on the label :

