

## VEGAPULS SR 68

4 ... 20 mA/HART - two-wire

Radar sensor for continuous level measurement of bulk solids



### Application area

The VEGAPULS SR 68 is a radar sensor for continuous measurement of bulk solids even under difficult process conditions. It is particularly suitable for level measurement in high silos and large bunkers. The VEGAPULS SR 68 is an economical solution thanks to the simple setup and the reliable, maintenance-free operation.

### Your benefit

- Maintenance-free operation thanks to non-contact measuring principle
- High plant availability, because wear and maintenance free
- Reliable measurement independent of steam, dust and noise

### Function

Extremely short microwave pulses are emitted by the antenna system in the direction of the measured product, reflected by the product surface and received back again by the antenna system. The time from emission to reception of the signals is proportional to the level in the vessel. A special time stretching procedure allows reliable and precise measurement of the extremely short signal running times.

### Technical data

Measuring range up to	30 m (98.43 ft)
Deviation	±2 mm
Process fitting	Thread from G1½; 1½ NPT; flanges from DN 40, 1½"
Process pressure	-1 ... +100 bar/-100 ... +10000 kPa (-14.5 ... +1450 psig)
Process temperature	-40 ... +250 °C (-40 ... +482 °F)
Ambient, storage and transport temperature	-40 ... +80 °C (-40 ... +176 °F)
Operating voltage	9.6 ... 36 V DC

### Materials

The wetted parts of the instrument are made of 316L resp. PTFE or PEEK. The process seal is made of FKM or FFKM.

### Housing versions

The housings are available as single chamber or double chamber version in plastic, stainless steel or aluminium. They are available with protection ratings up to IP 68 (1 bar).

### Electronics versions

The instruments are available in different electronics versions. Apart from 4 ... 20 mA/HART in two and four-wire version, there are also digital versions with Profibus PA, Foundation Fieldbus and Modbus protocols. Another HART version is available with integrated accumulator.

### Supplementary electronics

For instruments with double chamber housing two supplementary electronics such as radio module or a power pack are available.

### Approvals

The instruments are suitable for use in hazardous areas and are approved, for example, according to ATEX.

## Operation

The adjustment of the instrument is carried out via the optional display and adjustment module PLICSCOM or via a PC with the adjustment software PACTware and corresponding DTM. Further adjustment options are possible via a HART Communicator as well as manufacturer-specific programs such as AMS™ or PDM.

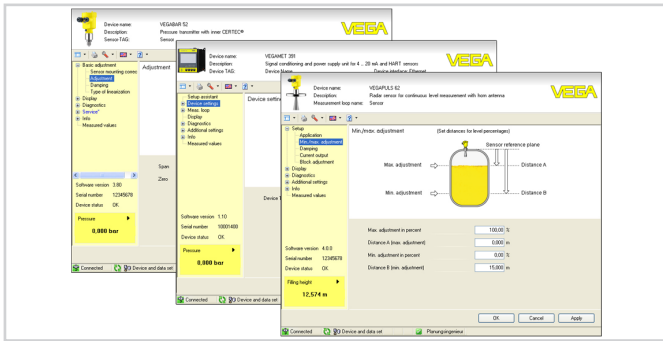

## Dimensions

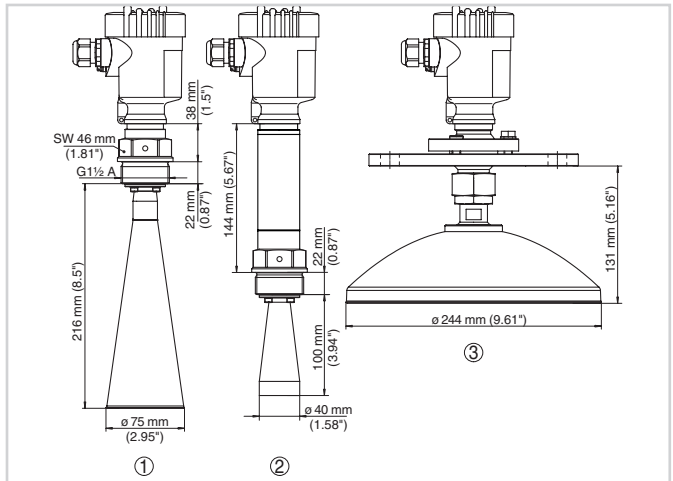

Dimensions VEGAPULS SR 68

- 1 Threaded version with horn antenna
- 2 Threaded version with horn antenna and temperature adapter
- 3 Version with parabolic antenna and swivelling holder

## Electrical connection

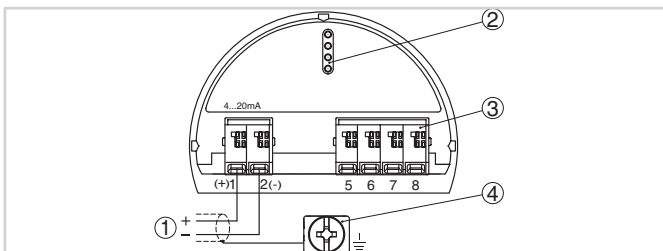

Electronics and terminal compartment, single chamber housing

- 1 Voltage supply/Signal output
- 2 For display and adjustment module or interface adapter
- 3 For external display and adjustment unit
- 4 Ground terminal for connection of the cable screen