

# Load-holding valve type LHK

## Product documentation

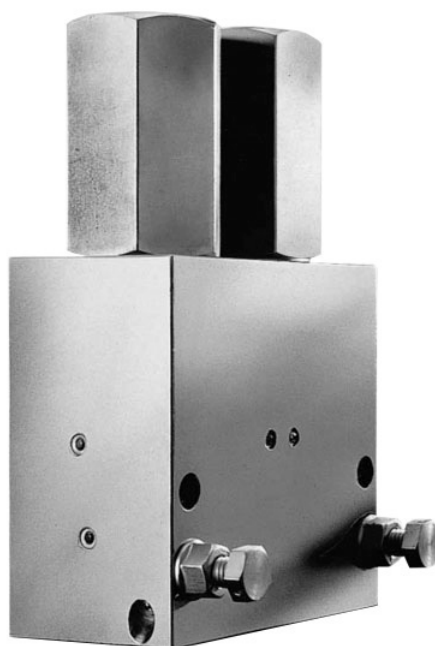

Pressure setting $p_{s \max}$ :	400 bar
Load pressure $p_{1 \max}$ :	320 bar
Flow rate $Q_{\max}$ :	100 l/min



## Table of Contents

<b>1</b>	<b>Overview of load-holding valve type LHK.....</b>	<b>4</b>
<b>2</b>	<b>Available versions.....</b>	<b>5</b>
2.1	Valves for one-sided load direction V → F.....	5
2.1.1	Basic type and size.....	6
2.1.2	Damping variant.....	8
2.2	Valves for load direction change.....	9
2.2.1	Basic type and size.....	9
2.2.2	Circuit symbol.....	10
2.3	Load-holding valve inserts.....	12
2.3.1	Basic type and size.....	13
<b>3</b>	<b>Parameters.....</b>	<b>14</b>
3.1	General data.....	14
3.2	Weight.....	15
3.3	Characteristic lines.....	16
<b>4</b>	<b>Dimensions.....</b>	<b>17</b>
4.1	Valves for one-sided load direction V → F.....	17
4.2	Valves for load direction change.....	33
4.3	Load-holding valve inserts.....	37
<b>5</b>	<b>Installation, operation and maintenance information.....</b>	<b>50</b>
5.1	Intended use.....	50
5.2	Assembly information.....	50
5.3	Operating instructions.....	50
5.4	Maintenance information.....	51
<b>6</b>	<b>Other information.....</b>	<b>52</b>
6.1	Pressure setting.....	52
6.2	Circuit examples.....	54
6.3	Notes on directional spool valve control systems.....	56

## 1 Overview of load-holding valve type LHK

Load-holding valves are a type of pressure valve. They prevent loads on cylinders or motors dropping in an uncontrolled manner. For this purpose they are pre-loaded with a pressure setting that is higher than the largest possible load. A hydraulic piston controls the opening of the valve to achieve the required lowering velocity.

The load-holding valves type LHK are suitable for applications that are not particularly prone to oscillations.

Shock valves and shuttle valves with or without restrictor check valve can be fitted in the load-holding valves type LHK, e.g. to relieve hydraulic brakes with a delay.

### Features and advantages

- Pressure settings up to 400 bar
- Various adjustment options
- Various models

### Intended applications

- Cranes
- Construction machinery
- Lifting devices



*Load-holding valve type LHK*

## 2 Available versions

### 2.1 Valves for one-sided load direction V → F

#### Ordering examples

LHK 22	G	-11 H	-180	/220
LHK 33	G	-15 C	-250	
LHK 44	F	-14 W	-200	

Shock setting (bar) <sup>2)</sup> <sup>3)</sup>

Pressure setting (bar) <sup>1)</sup> <sup>3)</sup>

Circuit symbol and housing version 2.1.1 "Basic type and size"

2.1.2 "Damping variant"

2.1.1 "Basic type and size"

1) Different pressure ranges (compression springs) according to the specified pressure setting.

2) Shock pressure  $p_{\max} \leq 340$  bar (pressure ranges: 150 to 250 bar and 251 to 340 bar)

3) If no specification is present, the setting is 80% of the  $p_{\max}$  of the respective pressure range.

## 2.1.1 Basic type and size

Type	Damping variant see Chapter 2.1.2	Circuit symbol and housing version		Release ratio	Flow rate Q <sub>max</sub> (l/min)	Pressure setting p <sub>max</sub> (bar) *	Ports (ISO 228-1)	
							A, B, F/V, R	
LHK 21	G	-14	Threaded connection	1 : 4.6	15	50 to 200	G 1/4	
		-14 T					50 to 200 201 to 400	G 3/8
		-14 T-3/8						
LHK 22	G, F, U	-11	Threaded connection	1 : 4.6	20	50 to 200 201 to 400	G 3/8	
		-11 H	V-banjo bolt connection				M16x1.5 G 3/8	
		-11 H16						
		-11 K -11 P	V-flange port				G 3/8	
LHK 227	G, F	-11 K	V-flange port	1 : 7	20	50 to 200 201 to 400	G 3/8	
LHK 30	G, F	-11 PV -11 C PV	Manifold mounting, external pressure adjustment	1 : 4.4	60	60 to 130 131 to 320 321 to 360	--	
LHK 32	G, F, U	-11	Threaded connection	1 : 4.4	40	60 to 130 131 to 320	G 3/8	
LHK 33	G, F, U	-11 -11 C	Threaded connection	1 : 4.4	60	60 to 130 131 to 320 321 to 360	G 1/2	
		-11 H	V-banjo bolt connection					
		-11 K -11 P	V-flange port					
		-14 -14 W -15 -15 C	Threaded connection					
LHK 337	G, F, U	-11	Threaded connection	1 : 7	60	60 to 130 131 to 320 321 to 360	G 1/2	
		-11 K -11 P	V-flange port					
LHK 40	G, F	-11 PV -11 C PV	Manifold mounting, external pressure adjustment	1 : 4.4	100	0 to 159 160 to 350	--	
LHK 43		-14	Threaded connection	1 : 4.4	80		G 3/4 G 1/2	
LHK 44	G, F, U	-11 -11 C	Threaded connection	1 : 4.4	100	0 to 159 160 to 350	G 3/4	
		-11 P	V-flange port					
		-14 -14 W	Threaded connection					
		-14 W M1C	V-flange port					
		-15 -15 C	Threaded connection					

\* Different pressure ranges (compression springs) according to the specified pressure setting.

**Circuit symbols**

**-11**

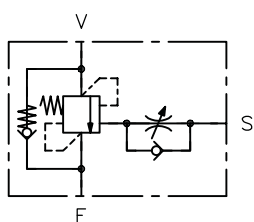

**-11 C**

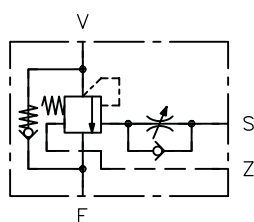

**-11 K  
-11 P**

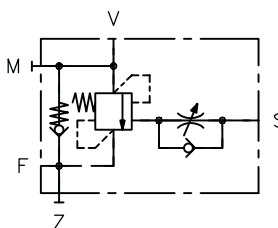

**-11 H  
-11 H16**

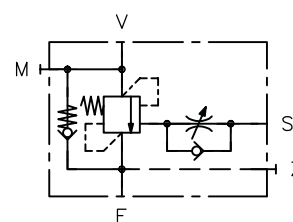

**-11 PV**

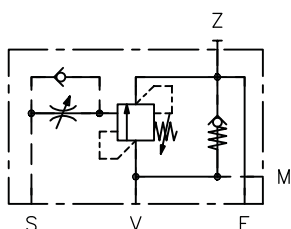

**i INFORMATION**

**Circuit symbols -11, -11C**

The valve is released from the inflow-side load line via an external control line S. In version **-11**, the control piston rear chamber is connected to port F, i.e. the return pressure (flow resistance of the directional valve and tank line) influences the opening behaviour of the valve. This is also the reason for the functional restriction in differential circuits (see "functional restriction").

With circuit symbol **-11C**, the rear side of the control piston is routed out separately (connection Z, route to the tank without pressure). This eliminates the influence of return pressure.

This version can also be used with the differential circuit mentioned above, as well as for retrofitting existing directional valves with a directional spool valve closed in the neutral position (ensures safe closing of the load-holding valve).

**-14**

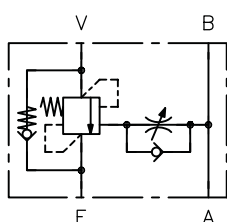

**-14 W**

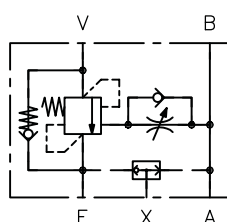

**-14 W M1C**

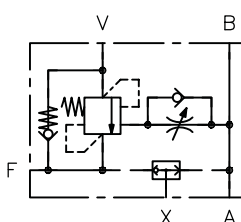

**-14 T  
-14 T-3/8**

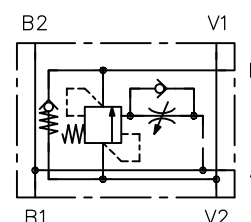

**i INFORMATION**

**Circuit symbols -14, -14W, -14W M1C**

Opposite the circuit symbol **-11**, internally routed load line (A - B) with control line tapping. This eliminates the need for piping of the control line.

The **-14W** version also has an integrated shuttle valve for a brake control line (connection X), e.g. for hydraulic motors with hydraulically released brakes (winches, etc.).

The **-14W M1C** version is a variant that can be directly flanged onto Denison motors (e.g. type M1C) or VOAC motors (e.g. type F 12).

-15

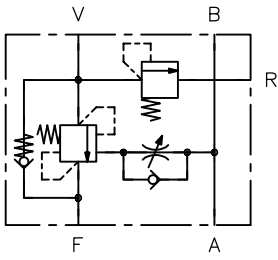

-15 C

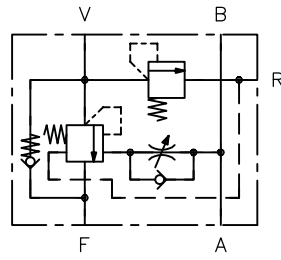

**i** INFORMATION

**Circuit symbols -15, -15C**

The cylinder side is protected with an additional shock valve. This means that there is a separation between maximum load pressure (set here on the shock valve) and opening behaviour (depending on the pilot ratio and pressure setting on the load-holding valve).

**2.1.2 Damping variant**

Coding	Description	Circuit symbol
G	damped with restrictor check valve combination (throttle screw adjustable)	
F	simply damped with throttle screw (adjustable)	
U	undamped	

## 2.2 Valves for load direction change

### Ordering examples

LHK 22	G	-21	-220	/220		
LHK 33	G	-25 WD	-280	/280	-260	/260
LHK 44	F	-21	-180	/180		

Shock setting V2 (bar) <sup>2)</sup> <sup>3)</sup>

Shock setting V1 (bar) <sup>2)</sup> <sup>3)</sup>

Pressure setting V2 (bar) <sup>1)</sup> <sup>3)</sup>

Pressure setting V1 (bar) <sup>1)</sup> <sup>3)</sup>

[2.2.2 "Circuit symbol"](#)

[2.1.2 "Damping variant"](#)

[2.2.1 "Basic type and size"](#)

1) Different pressure ranges (compression springs) according to the specified pressure setting.

2) Pressure setting for shock valve  $p_3$ ,  $p_{4 \max} \leq 400$  bar (pressure ranges: 0 to 160 bar, 161 to 315 bar and 316 to 400 bar)

3) If no specification is present, the setting is 80% of the  $p_{\max}$  of the respective pressure range.

### 2.2.1 Basic type and size

Type	Flow rate $Q_{\max}$ (l/min)	Pressure $p_{1 \max}$ (bar)	Possible damping variants <a href="#">see Chapter 2.1.2</a>
LHK 22	20	50 to 200 201 to 400	G, F, U
LHK 33	60	60 to 130 131 to 320	
LHK 337		321 to 360	
LHK 44	100	60 to 160	
LHK 447		161 to 350	

## 2.2.2 Circuit symbol

Coding	suitable for type	Housing version	Pilot ratio	Ports (ISO 228-1)
				A, B, F, V, R
-21	LHK 22	Threaded connection	1 : 4.6	G 3/8
-21 -21 W	LHK 33		1 : 4.4	G 1/2
-25 -25 W -25 WD				
-21	LHK 337		1 : 7	G 3/4
-25				
-21 -21 W	LHK 44		1 : 4.4	G 3/4
-21	LHK 447		1 : 7	

### Circuit symbols

-21

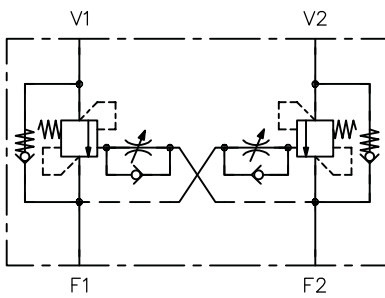

-21 W

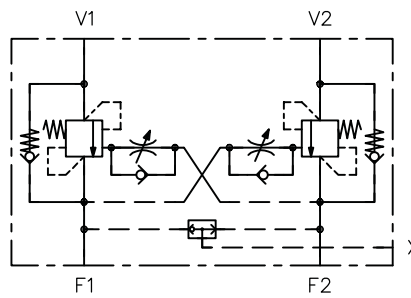

**i** **INFORMATION**

**Circuit symbols -21, -21W**

Valve for load direction change (e.g. passing a dead centre).

Both sides can be set independently of one another (load pressure and damping behaviour).

The **-21W** version also has an integrated shuttle valve (see circuit symbol **-14W**).

-25

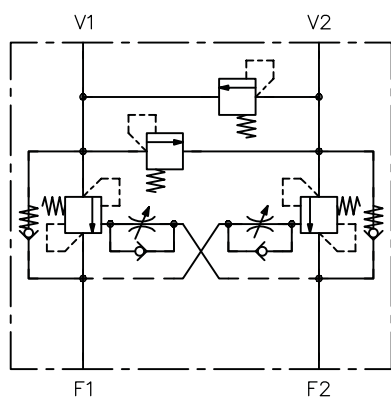

-25 W

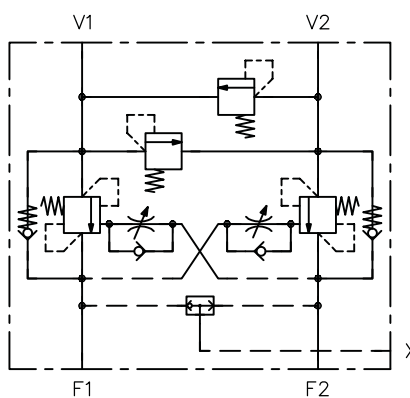

-25 WD

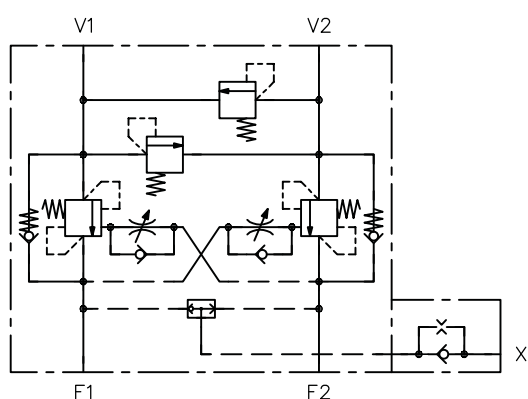

**i** **INFORMATION**

**Circuit symbols -25, -25W, -25WD**

Version for turning, swivelling or rotating devices using hydraulic motors. A shuttle valve can be integrated analogously to the circuit symbol **-14W** (see circuit symbol **-14W**). An additional restrictor check valve with circuit symbol **-25WD** enables a delayed relief of the hydraulic brake (soft application).

## 2.3 Load-holding valve inserts

For self-made basic bodies with connections V and S, installation kits can be supplied in individual parts. The functional test and pressure setting must then be implemented on site after assembly. The specification of the intended load pressure is necessary for the correct spring selection.

Notes on setting: see Chapter 6.1, "Pressure setting"

Type FG 2 as per D 7275 (connection A = control piston side, connection B = control inflow side) is suitable as a restrictor check valve for control piston damping.

### Ordering examples

LHK 21	-180
LHK 30 V	-260
LHK 447	-120

intended pressure setting  $p_1$  (bar)

#### 2.3.1 "Basic type and size"

## 2.3.1 Basic type and size

Type	Pilot ratio	Flow rate $Q_{\max}$ (l/min)	Pressure $p_{1 \max}$ (bar) <sup>1) 2)</sup>	Ports (ISO 228-1)	used for circuit symbol	
LHK 20 V	1 : 4.6	15	50 to 200	-- <sup>3)</sup>	--	
LHK 21				G 1/4	-14.	
LHK 22		20	50 to 200 201 to 400	G 3/8	11., 21	
LHK 227	11.					
LHK 30 V	1 : 4.4	60	60 to 130 131 to 320 321 to 360	-- <sup>3)</sup>	11 PV 11 CPV	
LHK 32				40	60 to 130 131 to 320	G 3/8
LHK 33		60	60 to 130 131 to 320 321 to 360	G 1/2	11., 14., 15. 17., 21., 25.	
LHK 33 S					11 SK	
LHK 33 SL					21 SL	
LHK 337		1 : 7				11., 21., 25
LHK 40 V		1 : 4.4	100	60 to 130 131 to 350	-- <sup>3)</sup>	11 PV 11 CPV
LHK 44	G 3/4				11., 14. 15., 21.	
LHK 447					21	

1) Different pressure ranges (compression springs) according to the specified pressure setting.

2) If no specification is present, the setting is 80% of the  $p_{\max}$  of the respective pressure range.

3) All ports are located on the basic body. The pressure setting can be adjusted by loosening a lock nut.

### Circuit symbol

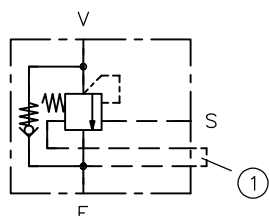

1 Connecting hole Y

see Chapter 4.3, "Load-holding valve inserts"

## 3 Parameters

### 3.1 General data

<b>Designation</b>	Load-holding valve, with hydraulic relief, with bypass check valve
<b>Design</b>	<ul style="list-style-type: none"> <li>Pressure valve part (load-holding valve): Ball or conical seat valve</li> <li>Bypass check valve: Manifold seated valve</li> </ul>
<b>Model</b>	<ul style="list-style-type: none"> <li>Single or twin valve for pipe connection</li> <li>Manifold mounting valve</li> <li>Screw-in valve, version for banjo bolt mounting</li> </ul>
<b>Material</b>	<p>Steel</p> <p>Surface treatment:</p> <ul style="list-style-type: none"> <li>Electro-galvanised blocks</li> <li>Spring housing: nitrocarburised</li> </ul>
<b>Attachment</b>	see Chapter 4, "Dimensions"
<b>Tightening torque</b>	see Chapter 4, "Dimensions"
<b>Installation position</b>	As desired
<b>Ports/connections</b>	<ul style="list-style-type: none"> <li><b>F (1, 2); V (1, 2); A, B, R</b> = Main pressure connections depending on the type</li> <li><b>S, X, M</b> = Control ports and measurement fittings depending on the type</li> </ul> <p>All ports can withstand full operating pressure.</p>
<b>Flow direction</b>	<p><b>Working direction (load-holding function)</b></p> <ul style="list-style-type: none"> <li>V (1, 2) → F (1, 2)</li> </ul> <p><b>Free flow</b></p> <ul style="list-style-type: none"> <li>F (1, 2) → V (1, 2)</li> </ul>
<b>Pilot ratio</b>	<p>The release pressure corresponds to the following multiples of the difference between the pressure setting and the load pressure at the following ratios:</p> <ul style="list-style-type: none"> <li>at 1 : 4.4 = 0.23x</li> <li>at 1 : 4.6 = 0.22x</li> <li>at 1 : 7 = 0.14x</li> </ul> <p>The surface ratio for hydraulic cylinders is taken into account in the calculation.</p>
<b>Hydraulic fluid</b>	<p>Hydraulic fluid, according to DIN 51524 Parts 1 to 3; ISO VG 10 to 68 according to DIN ISO 3448</p> <p>Viscosity range: 4 - 1500 mm<sup>2</sup>/s</p> <p>Optimal operating range: approx. 10 - 500 mm<sup>2</sup>/s</p> <p>Also suitable for biologically degradable hydraulic fluids type HEPG (polyalkylene glycol) and HEES (synthetic ester) at operating temperatures up to approx. +70°C.</p>
<b>Cleanliness level</b>	<p><b>ISO 4406</b></p> <hr/> <p>21/18/15...19/17/13</p>

### Temperatures

Environment: approx. -40 to +80 °C, hydraulic fluid: -25 to +80 °C, pay attention to the viscosity range. Start temperature: down to -40 °C is permissible (take account of the start viscosities!), as long as the steady-state temperature is at least 20 K higher during subsequent operation. Biologically degradable hydraulic fluids: note manufacturer specifications. With consideration for the seal compatibility, not above +70°C.

## 3.2 Weight

### Valves for one-sided load direction

Type	Weight	Type	Weight
LHK 21 ..-14	= 0.7 kg	LHK 33(7) ..-11 C	= 1.0 kg
LHK 21 ..-14 T(-3/8)	= 1.0 kg	LHK 33(7) ..-11.-...	= 1.0 kg
LHK 22 ..-11 K	= 0.5 kg	LHK 33 ..-..H	= 1.0 kg
LHK 22(7) ..-11-...	= 0.5 kg	LHK 40 ..-11 CPV	= 1.8 kg
LHK 22 ..-..H	= 0.6 kg	LHK 40 ..-11 PV	= 1.8 kg
LHK 22 ..-..H 16	= 0.6 kg	LHK 43 ..-14	= 2.6 kg
LHK 22 ..-11 P(K)-..	= 0.6 kg	LHK 44 ..-14 W M1C	= 2.5 kg
LHK 30 ..-11 CPV	= 1.5 kg	LHK 44 ..-14 (W)	= 2.6 kg
LHK 30 ..-11 PV	= 1.5 kg	LHK 44 G-15 (C)	= 2.6 kg
LHK 32 ..-11-...	= 1.0 kg	LHK 44(7) ..-11 C-...	= 1.6 kg
LHK 33 (337) ..-11 P(K)-...	= 1.0 kg	LHK 44(7) ..-11.-...	= 1.6 kg
LHK 33 ..-14 (W)	= 1.6 kg	LHK 44 ..-11-P(K)-..	= 2.0 kg
LHK 33 G-15 (C)	= 1.6 kg		

### Valves for load direction change

Type	Weight
LHK 22 ..-21	= 0.85 kg
LHK 33 ..-21 (W)	= 2.4 kg
LHK 33 ..-25-...	= 2.7 kg
LHK 33 ..-25 W	= 2.7 kg
LHK 33 ..-25 WD	= 2.7 kg
LHK 44 ..-21 (W)	= 3.5 kg

### Installation kits

Type	Weight
LHK 20 V	= 0.3 kg
LHK 21, LHK 22	= 0.1 kg
LHK 30 V	= 1.0 kg
LHK 32, LHK 33	= 0.3 kg
LHK 33 S	= 1.2 kg
LHK 40 V	= 1.3 kg
LHK 44	= 1.0 kg

### 3.3 Characteristic lines

Viscosity of the hydraulic fluid approx. 50 mm<sup>2</sup>/s

#### $\Delta p$ -Q characteristic lines

For self-manufactured housings (port side F), the flow resistance may vary depending on the design of the oil channels.

##### LHK 21

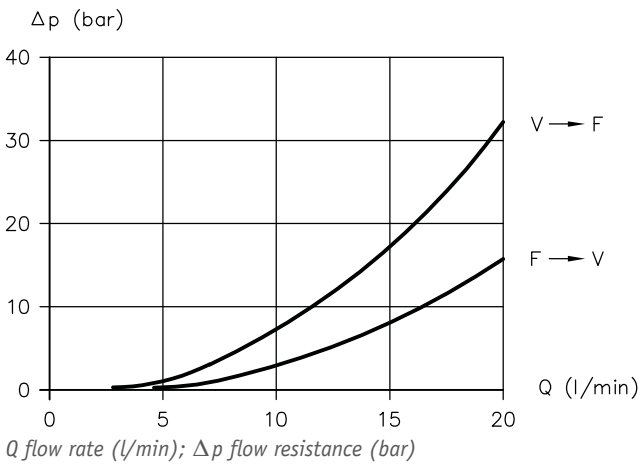

##### LHK 20, LHK 22

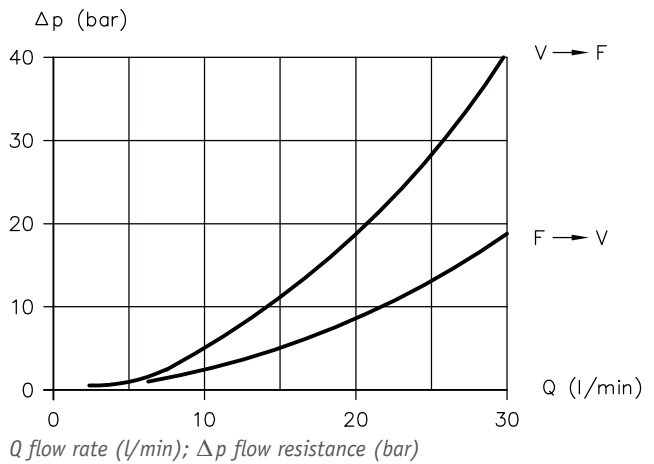

##### LHK 30, LHK 32 LHK 33, LHK 337

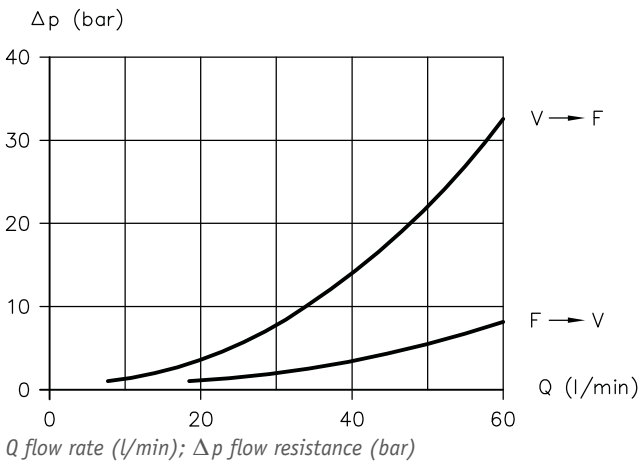

##### LHK 40, LHK 43 LHK 44, LHK 447

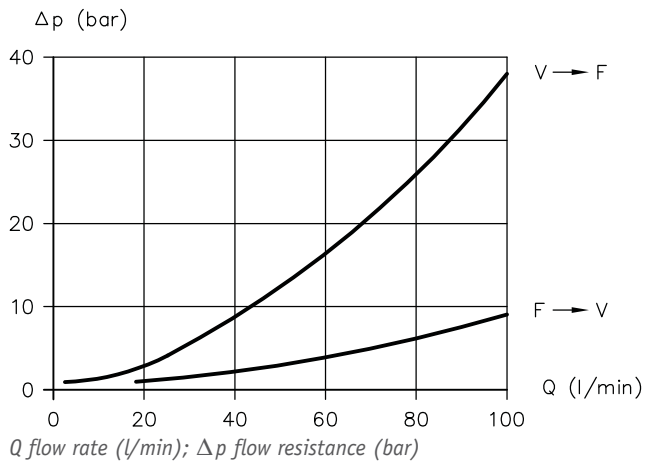

#### **NOTICE** Functional restriction

Load-holding valves cannot be used in conjunction with directional spool valves with the flow diagram of the differential circuit in a (any) switching position (e.g. with coding **C**, **Y** according to [D 5650/1](#)).

Do not use load-holding valves with circuit symbol **-15** on the rod side of the connected cylinder. Exception: Load-holding valves with circuit symbols **-11C** or **-15C** with external control piston relief (port Z).

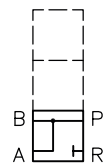

## 4 Dimensions

All dimensions in mm, subject to change.

### 4.1 Valves for one-sided load direction $V \rightarrow F$

LHK .. -11  
LHK .. -11 C

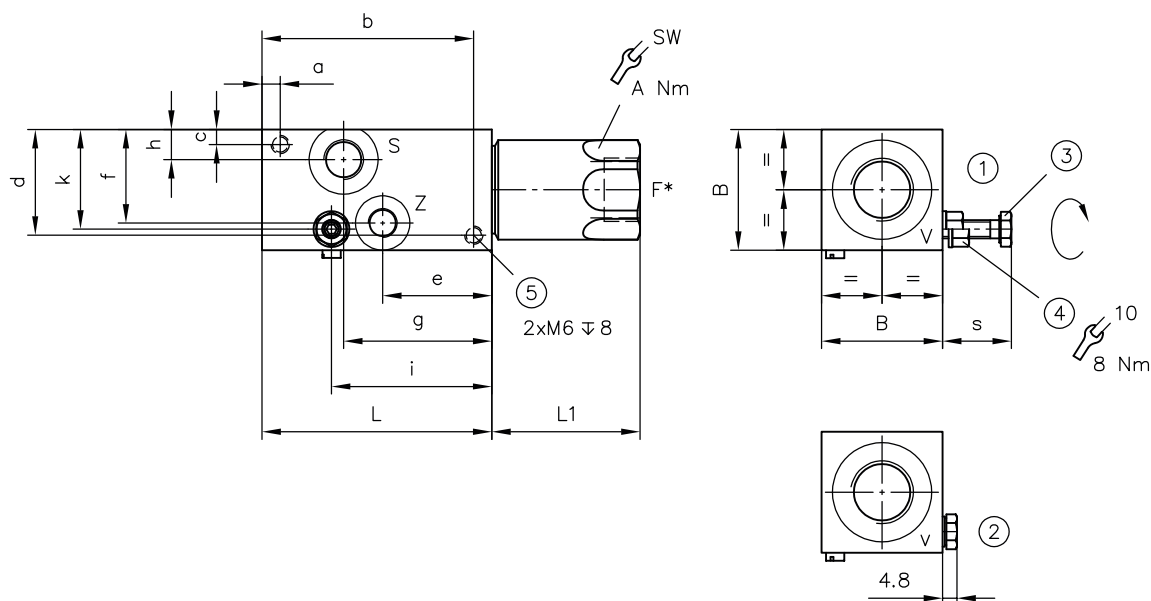

SW = Width across flats

- 1 With coding **G**: Check valve and throttle screw  
With coding **F**: Throttle screw, but no check valve (hole sealed)
- 2 With coding **U**: no check valve, no throttle screw (tapped plugs instead)
- 3 Grub screw SW3 (LHK 22) or hex bolt SW10 (LHK 3., LHK 44) for valve damping. Throttle effect increases clockwise.
- 4 Loosen the lock nut (seal-lock nut) sufficiently before adjusting the hex bolt, in order to prevent the thread from damaging the vulcanised sealing ring,
- 5 only for type LHK 3. and LHK 44

\* **NOTICE**  
When assembling the connection fittings, hold the hexagonal spring housing in place!

Type	L	B	a	b	c	d	e	f	g	h	i	k	s	
													min	max
LHK 22 -11	57	32	--	--	--	--	--	--	35	8	35	25	8	17
LHK 32 -11	74	40	5	69	5	35	--	--	49	10	53	33	14	24
LHK 33(7) -11	76	40	6	70	5	35	--	--	49	10	53	33	14	24
LHK 33 -11 C	76	40	6	70	5	35	36.1	31	49	10	53	33	14	24
LHK 44 -11	80	45	5	75	5	40	--	--	51.5	21	55	39.5	14	24
LHK 44 -11 C	80	45	5	75	5	40	38	36	51.5	21	55	39.5	14	24

\* **NOTICE**  
Do not unscrew the thread type throttle beyond  $S_{max}$ . Due to the design, it cannot be secured inside the device!

Type	SW	max. tightening torque (Nm)	Ports (ISO 228-1)		
			A	V, F	S
LHK 22 -11	22	30	G 3/8	G 1/8	--
LHK 32 -11	30	160	G 3/8	G 1/4	--
LHK 33(7) -11	30	160	G 1/2	G 1/4	--
LHK 33 -11 C	30	160	G 1/2	G 1/4	G 1/8
LHK 44 -11	36	180	G 3/4	G 1/4	--
LHK 44 -11 C	36	180	G 3/4	G 1/4	G 1/8

LHK 22 -H  
LHK 22 -H16

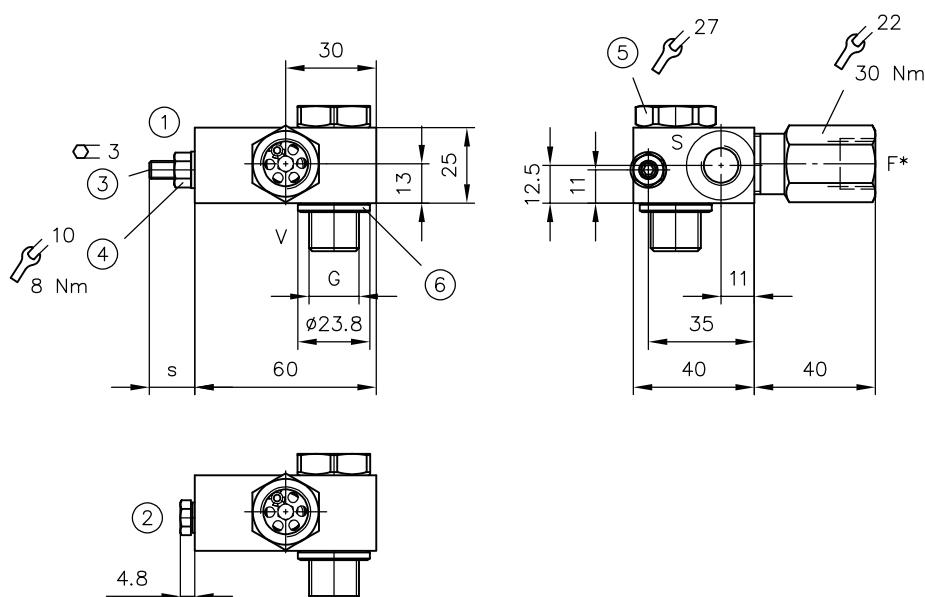

- 1 With coding **G**: Check valve and throttle screw  
With coding **F**: Throttle screw, but no check valve (hole sealed)
- 2 With coding **U**: no check valve, no throttle screw (tapped plugs instead)
- 3 Grub screw for valve damping. Throttle effect increases clockwise.
- 4 Loosen the lock nut (seal-lock nut) sufficiently before adjusting the hex bolt, in order to prevent the thread from damaging the vulcanised sealing ring,
- 5 Banjo bolt (360° rotatable housing) can be fitted on both sides
- 6 Sealing edge ring ERMETO DKA 3/8  
The diameter of the sealing edge ring and the reflection are identical.

\* **NOTICE**  
When assembling the connection fittings, hold the hexagonal spring housing in place!

Type	G	s		Ports (ISO 228-1)	
		min	max	F	S
LHK 22 -11 H	G 3/8 A	8	17	G 3/8	G 1/4
LHK 22 -11 H16	M16x1.5	8	17	G 3/8	G 1/4

\* **NOTICE**  
Do not unscrew the thread throttle beyond  $S_{max}$ . Due to the design, it cannot be secured inside the device!

LHK 33 -11 H

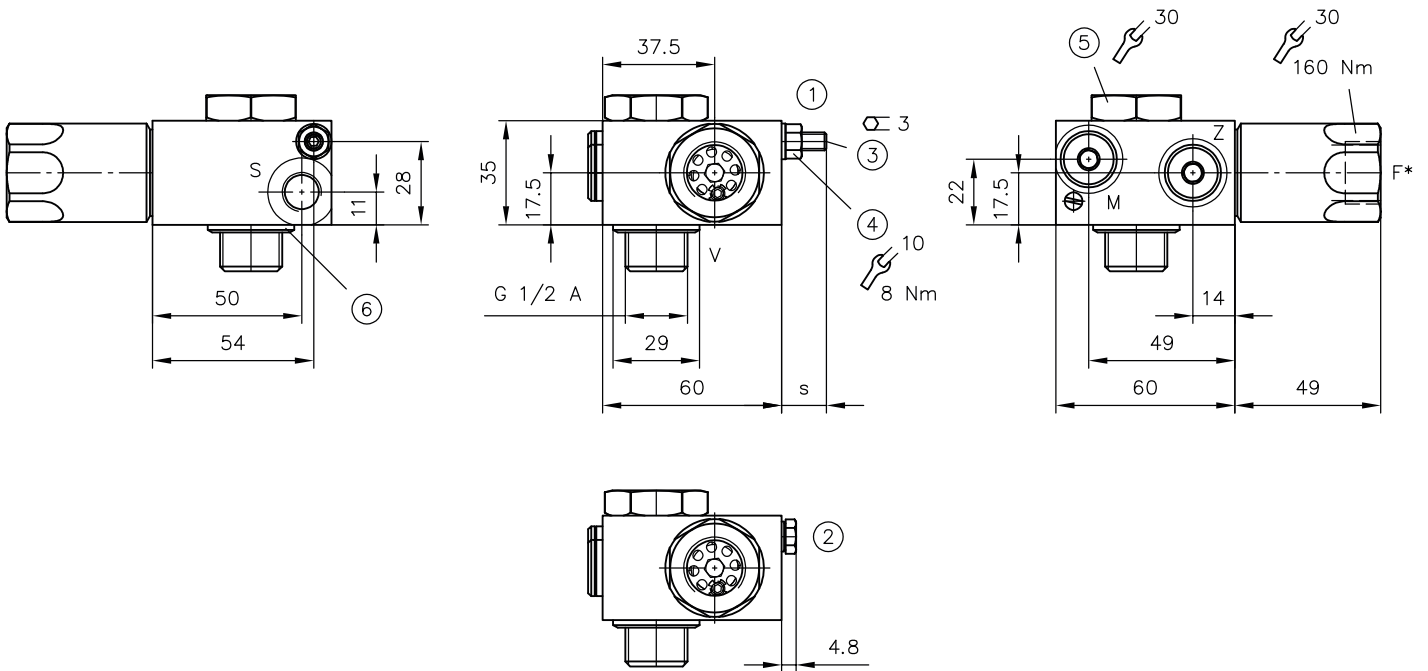

- 1 With coding **G**: Check valve and throttle screw  
With coding **F**: Throttle screw, but no check valve (hole sealed)
- 2 With coding **U**: no check valve, no throttle screw (tapped plugs instead)
- 3 Grub screw for valve damping. Throttle effect increases clockwise.
- 4 Loosen the lock nut (seal-lock nut) sufficiently before adjusting the hex bolt, in order to prevent the thread from damaging the vulcanised sealing ring,
- 5 Banjo bolt (360° rotatable housing) can be fitted on both sides
- 6 Sealing edge ring ERMETO DKA 1/2  
The diameter of the sealing edge ring and the reflection are identical.

\* **NOTICE**  
When assembling the connection fittings, hold the hexagonal spring housing in place!

Type	s		Ports (ISO 228-1)	
	min	max	F	M, S, Z
LHK 33 -11 H	6	15	G 1/2	G 1/4

\* **NOTICE**  
Do not unscrew the thread throttle beyond  $S_{max}$ . Due to the design, it cannot be secured inside the device!

LHK .. -11 PV  
LHK .. -11 CPV

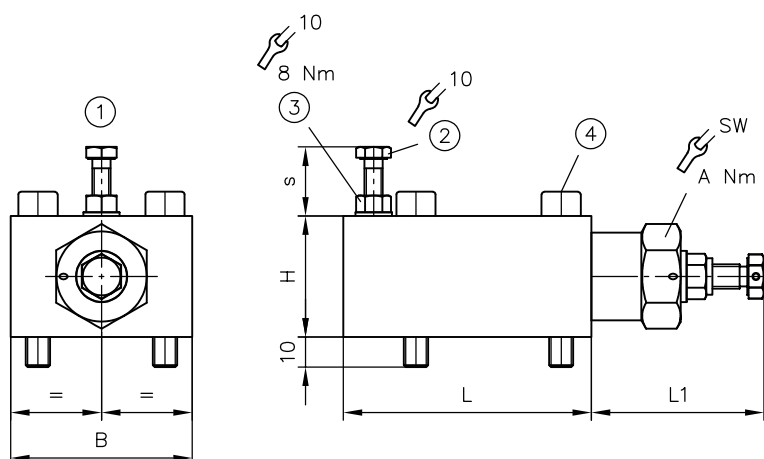

SW = Width across flats

- 1 With coding **G**: Check valve and throttle screw  
With coding **F**: Throttle screw, but no check valve (hole sealed)
- 2 Hex bolt for valve damping. Throttle effect increases clockwise.
- 3 Loosen the lock nut (seal-lock nut) sufficiently before adjusting the hex bolt, in order to prevent the thread from damaging the vulcanised sealing ring,
- 4 Cylinder screws  
LHK 30: DIN 912-M8x50-8.8-A2K  
LHK 40: DIN 912-M8x60-8.8-A2K

Type	L	L1	B	H	s		SW	max. tightening torque (Nm)
					min	max		A
LHK 30 -11 PV LHK 30 -11 CPV	82	57	60	40	14	24	30	160
LHK 40 -11 PV LHK 40 -11 CPV	80	85	62	50	12	24	36	180

**! NOTICE**

Do not unscrew the thread type throttle beyond  $S_{max}$ . Due to the design, it cannot be secured inside the device!

**Hole pattern of the base plate**

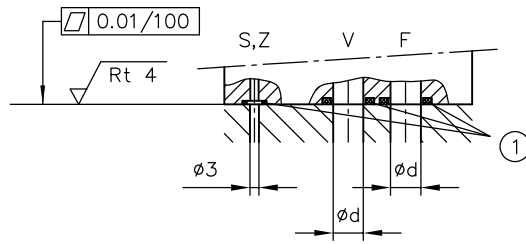
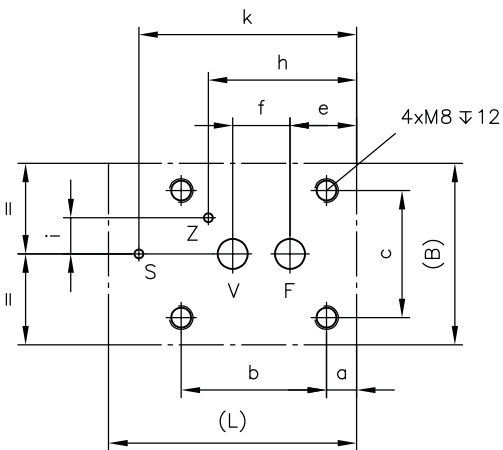

1 O-ring

Type	L	B	a	b	c	e	f	h	i	k	Ød	O-ring NBR 90 Sh	
												F, V	S, Z
LHK 30 -11 PV	82	60	10	48	42	22	19	--	--	72	10	12.37x2.62	4.47x1.78
LHK 30 -11 CPV								49	12				
LHK 40 -11 PV	80	62	17	50	48	28.5	24	--	--	74	14	17.12x2.62	4.47x1.78
LHK 40 -11 CPV								60	15				

LHK 22 G-11 K  
LHK 227 G-11 K

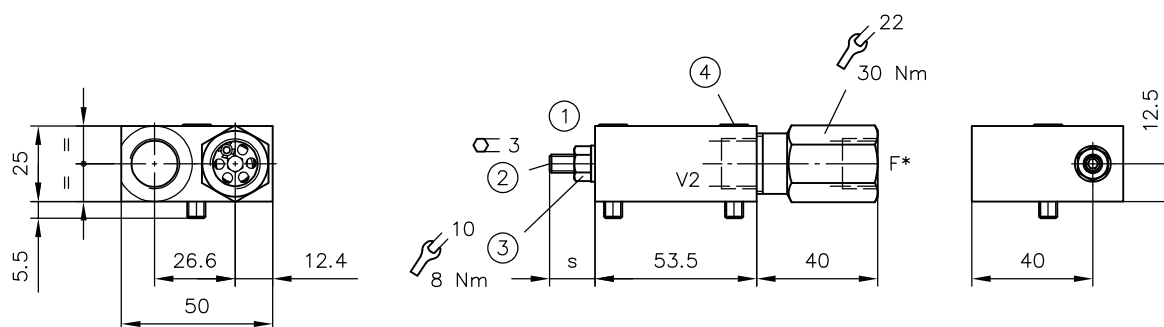

- 1 With coding G: Check valve and throttle screw
- 2 Hex bolt for valve damping. Throttle effect increases clockwise.
- 3 Loosen the lock nut (seal-lock nut) sufficiently before adjusting the hex bolt, in order to prevent the thread from damaging the vulcanised sealing ring,
- 4 Cylinder screws DIN 912-M6x25-8.8-A2K

\* **NOTICE**  
When assembling the connection fittings, hold the hexagonal spring housing in place!

Type	s		Ports (ISO 228-1)
	min	max	F, V2
LHK 22 G-11 K	8	17	G 3/8
LHK 227 G-11 K			

\* **NOTICE**  
Do not unscrew the thread type throttle beyond  $S_{max}$ . Due to the design, it cannot be secured inside the device!

**Hole pattern of the base plate**

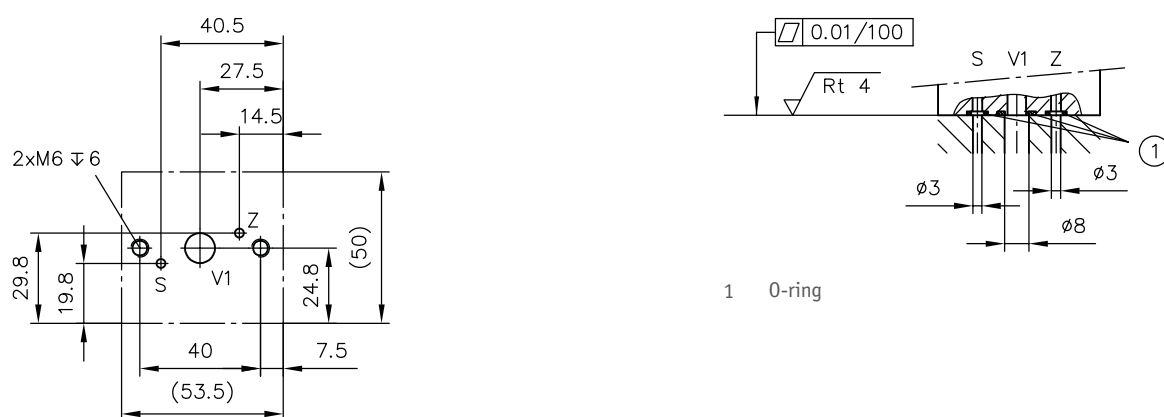

Type	O-ring NBR 90 Shore	
	V1	S, Z
LHK 22 G-11 K	9.25x1.78	3.7x1.78
LHK 227 G-11 K		

LHK ... -11 K  
LHK ... -11 P

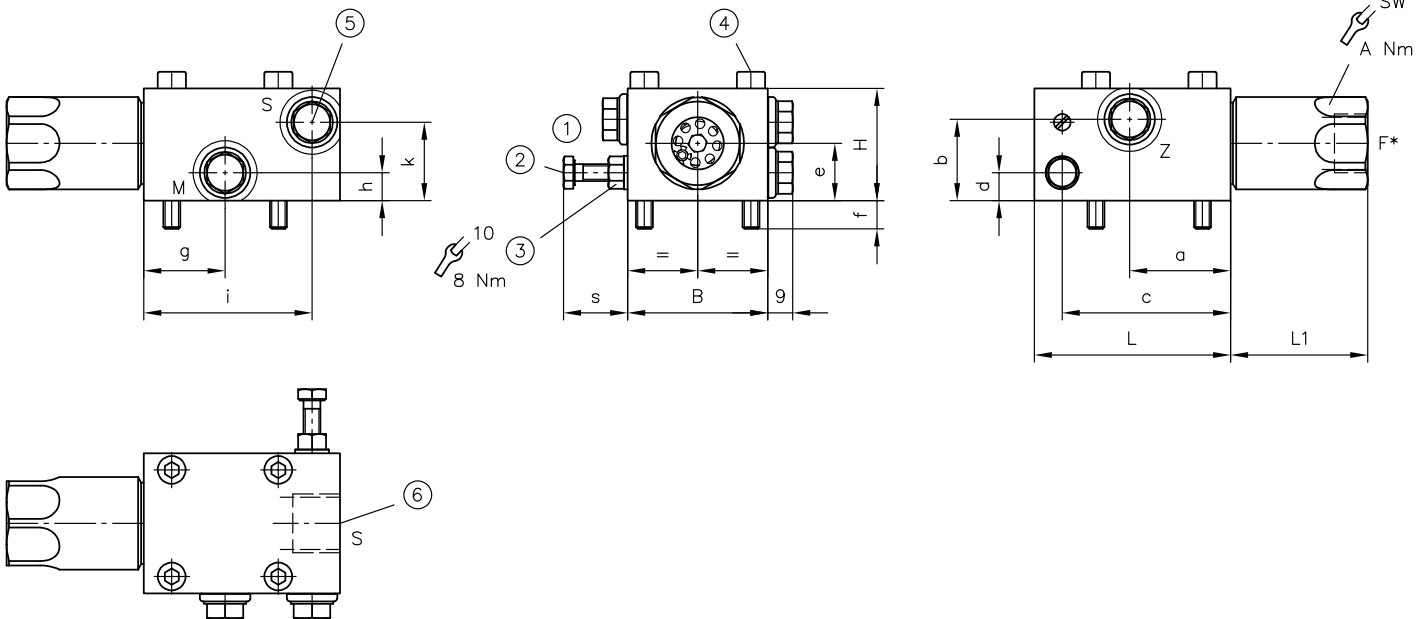

SW = Width across flats

- 1 With coding **G**: Check valve and throttle screw  
With coding **F**: Throttle screw, but no check valve (hole sealed)
- 2 Grub screw SW3 (LHK 22) or hex bolt SW10 (LHK 33, LHK 44) for valve damping. Throttle effect increases clockwise.
- 3 Loosen the lock nut (seal-lock nut) sufficiently before adjusting the hex bolt, in order to prevent the thread from damaging the vulcanised sealing ring,
- 4 Cylinder screws  
LHK 22: DIN 912-M6x35-8.8-A2K  
LHK 33: DIN 912-M6x50-8.8-A2K  
LHK 44: DIN 912-M6x60-8.8-A2K
- 5 Position of connection S with type LHK 33
- 6 Position of connection S with type LHK 22 -11 P

\* **NOTICE**  
When assembling the connection fittings, hold the hexagonal spring housing in place!

Type	L	L1	B	H	a	b	c	d	e	f	g	h	i	k
LHK 22 -11 P	64	40	40	28	--	--	44.75	14	14	7	--	--	--	--
LHK 33 -11 K LHK 33 -11 P	70	49	50	40	36	29	60	10	20.5	10	29	10	60	28
LHK 44 -11 P	60	90	60	48	--	--	54.5	12	25	12	--	--	--	--

Type	s		SW	max. tightening torque (Nm)	Ports (ISO 228-1)			
	min	max			A	F	S	M, Z
LHK 22 -11 P	8	15	22	30		G 3/8	G 3/8	--
LHK 33 -11 K LHK 33 -11 P	14	24	30	160		G 1/2	G 1/4	G 1/4
LHK 44 -11 P	12	24	36	180		G 3/4	--	--

\* **NOTICE**  
Do not unscrew the thread type throttle beyond  $S_{max}$ . Due to the design, it cannot be secured inside the device!

### Hole pattern of the base plate

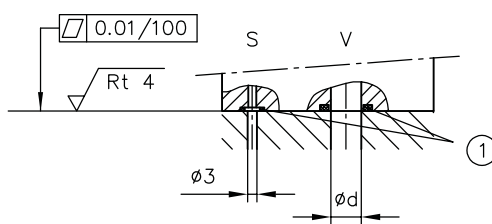
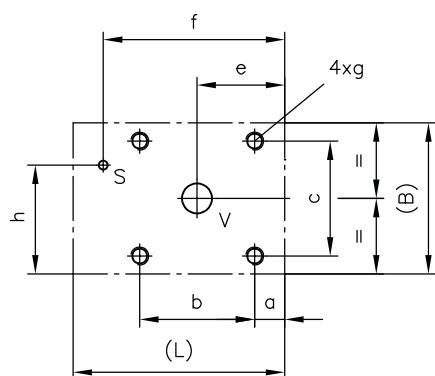

1 O-ring

Type	L	B	a	b	c	e	f	h	g	$\varnothing d$	O-ring NBR 90 Sh	
											V	S
LHK 22 -11 P	64	40	9.5	28	28	23.5	--	--	M6, 8 deep	8	10.77x2.62	--
LHK 33 -11 K	70	50	10	38	38	29	--	--	M6, 11 deep	10	12.37x2.62	--
LHK 33 -11 P	70	50	10	38	38	29	60	36	M6, 11 deep	10	12.37x2.62	4.47x1.78
LHK 44 -11 P	60	60	18	28	46	33	54.5	30	M8, 14 deep	14	15.55x2.62	4.47x1.78

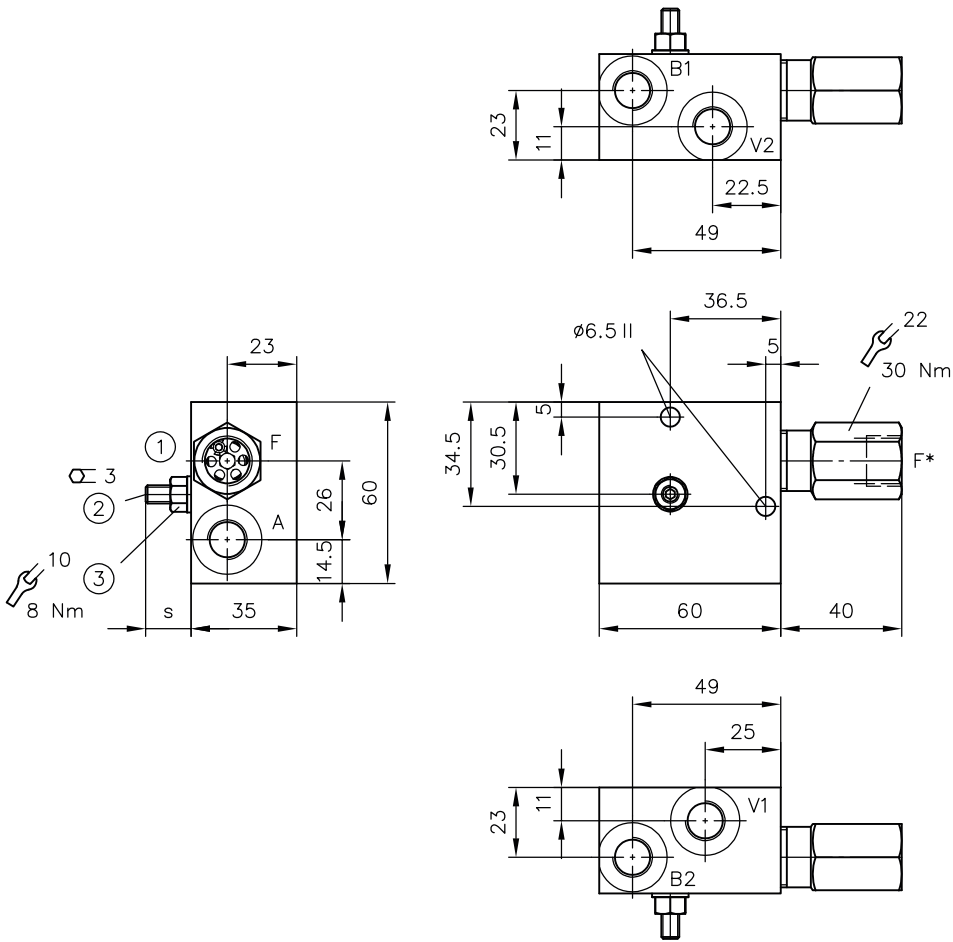

- 1 With coding **G**: Check valve and throttle screw
- 2 Hex bolt for valve damping. Throttle effect increases clockwise.
- 3 Loosen the lock nut (seal-lock nut) sufficiently before adjusting the hex bolt, in order to prevent the thread from damaging the vulcanised sealing ring,

\* **NOTICE**  
When assembling the connection fittings, hold the hexagonal spring housing in place!

Type	s		Ports (ISO 228-1)	
	min	max	F	A, B1, B2, V1, V2
LHK 21 -14 T	12	17	G 1/4	G 1/4
LHK 21 -14 T-3/8	12	17	G 3/8	G 1/4

\* **NOTICE**  
Do not unscrew the thread type throttle beyond  $S_{max}$ . Due to the design, it cannot be secured inside the device!

LHK 21 -14, LHK 33 -14  
LHK 43 -14, LHK 44 -14

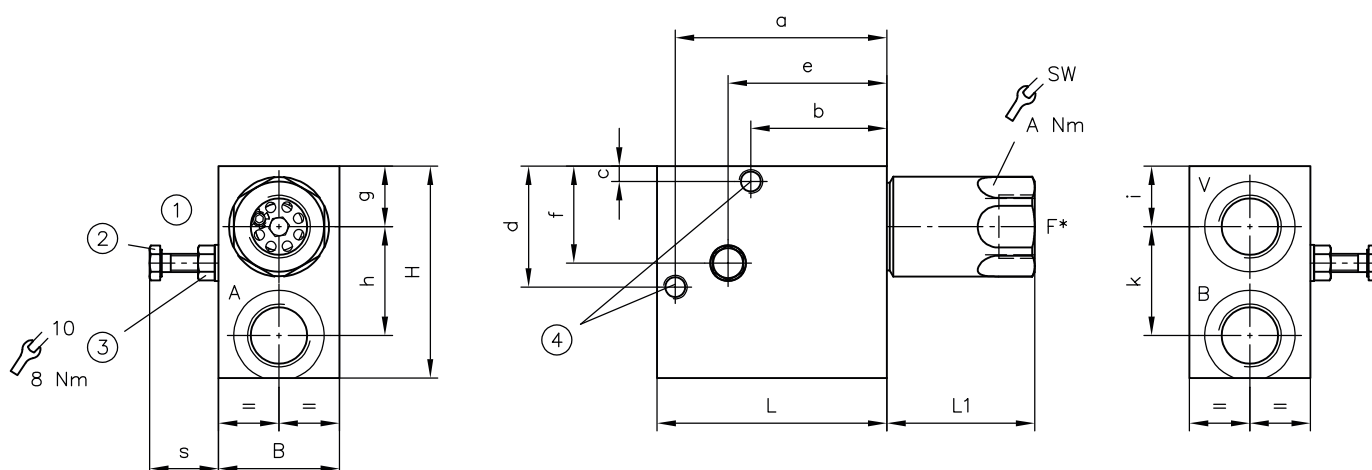

SW = Width across flats

- 1 With coding **G**: Check valve and throttle screw  
With coding **F**: Throttle screw, but no check valve (hole sealed)
- 2 Grub screw SW3 (LHK 22) or hex bolt SW10 (LHK 33, LHK 43(44)) for valve damping. Throttle effect increases clockwise.
- 3 Loosen the lock nut (seal-lock nut) sufficiently before adjusting the hex bolt, in order to prevent the thread from damaging the vulcanised sealing ring,
- 4 M8, 10 deep on both sides,  $\varnothing 6.8$  through; for type LHK 21, only  $\varnothing 6.5$  through

\* **NOTICE**  
When assembling the connection fittings, hold the hexagonal spring housing in place!

Type	L	L1	B	H	a	b	c	d	e	f	g	h	i	k
LHK 21 -14	57	40	30	50	47	17	28.5	0	35	24.5	15	24.5	11.5	28
LHK 33 -14	76	49	40	70	70	45	5	40	52.5	32	20	36	20	36
LHK 43 -14	80	90	50	80	73	47	6	46	54.5	46	23	40	23	40
LHK 44 -14	80	90	50	85	73	47	8	48	54.5	12	23	44	23	44

Type	s		SW	max. tightening torque (Nm)	Ports (ISO 228-1)		
	min	max			A	A, B	F, V
LHK 21 -14	12	17	22	30		G 1/4	G 1/4
LHK 33 -14	15	24	30	160		G 1/2	G 1/2
LHK 43 -14	14	25	36	180		G 1/2	G 3/4
LHK 44 -14	14	25	36	180		G 3/4	G 3/4

\* **NOTICE**  
Do not unscrew the thread type throttle beyond  $S_{max}$ . Due to the design, it cannot be secured inside the device!

LHK 33 -14 W  
LHK 44 -14 W

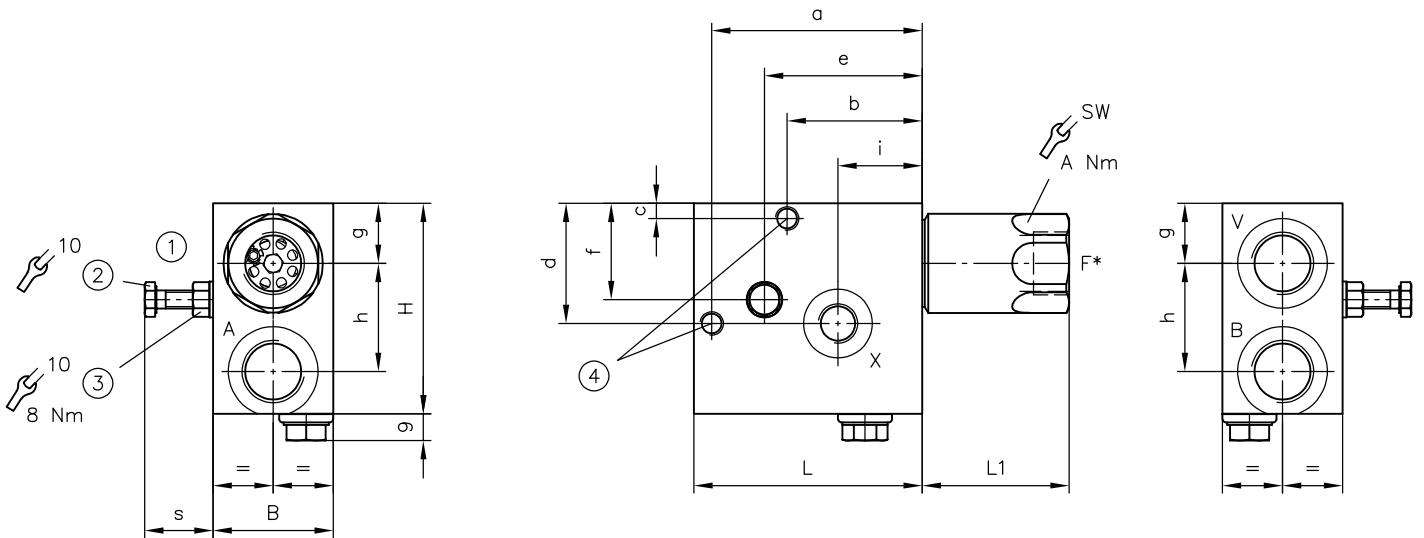

SW = Width across flats

- 1 With coding **G**: Check valve and throttle screw  
With coding **F**: Throttle screw, but check valve (hole sealed)
- 2 Hex bolt for valve damping. Throttle effect increases clockwise.
- 3 Loosen the lock nut (seal-lock nut) sufficiently before adjusting the hex bolt, in order to prevent the thread from damaging the vulcanised sealing ring,
- 4 M8, 10 deep on both sides,  $\varnothing 6.8$  through

\* **NOTICE**  
When assembling the connection fittings, hold the hexagonal spring housing in place!

Type	L	L1	B	H	a	b	c	d	e	f	g	h	i
LHK 33 -14 W	76	49	40	70	70	45	5	40	52.5	32	20	36	28
LHK 44 -14 W	80	90	50	85	73	47	8	48	54.5	12	23	44	32

Type	s		SW	max. tightening torque (Nm)	Ports (ISO 228-1)	
	min	max			A	X
LHK 33 -14 W	15	24	30	160	G 1/2	G 1/4
LHK 44 -14 W	14	25	36	180	G 3/4	G 1/4

**NOTICE**  
Do not unscrew the thread type throttle beyond  $S_{max}$ . Due to the design, it cannot be secured inside the device!

### LHK 44 -14 W M1C

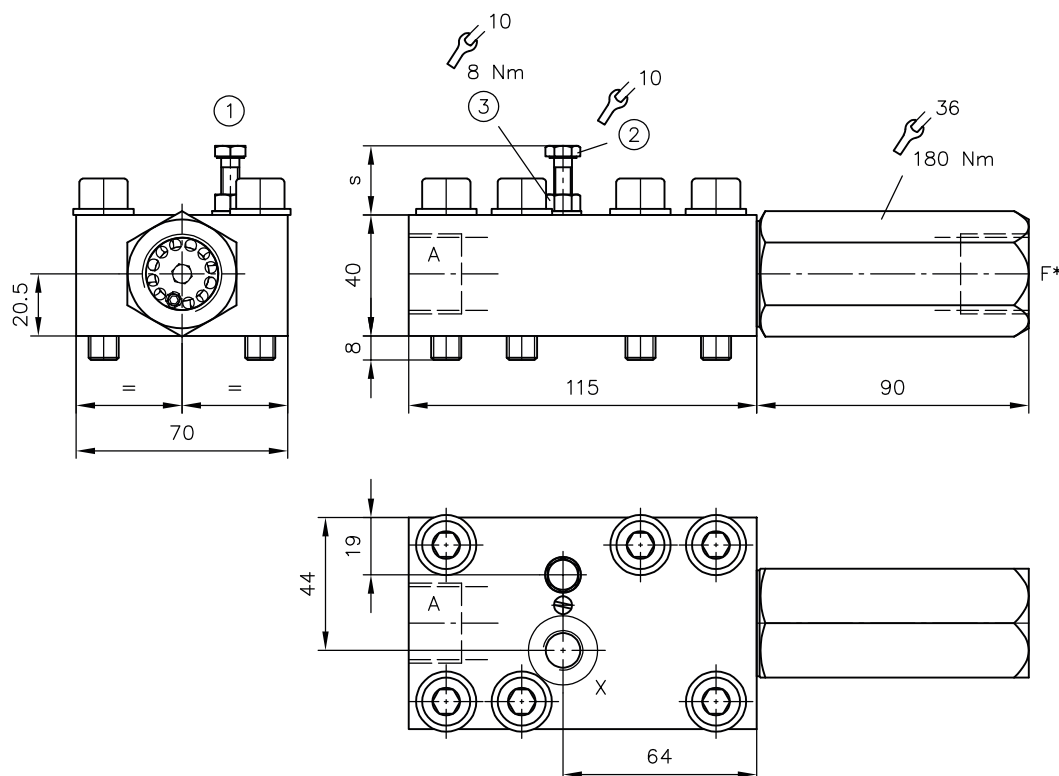

- 1 With coding **G**: Check valve and throttle screw
- 2 Hex bolt for valve damping. Throttle effect increases clockwise.
- 3 Loosen the lock nut (seal-lock nut) sufficiently before adjusting the hex bolt, in order to prevent the thread from damaging the vulcanised sealing ring,

\* **NOTICE**  
When assembling the connection fittings, hold the hexagonal spring housing in place!

Type	s		Ports (ISO 228-1)	
	min	max	F, A	X
LHK 44 -14 W M1C	14	24	G 3/4	G 1/4

\* **NOTICE**  
Do not unscrew the thread type throttle beyond  $S_{max}$ . Due to the design, it cannot be secured inside the device!

**Hole pattern of the base plate**

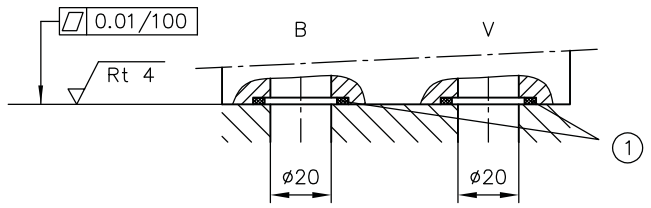
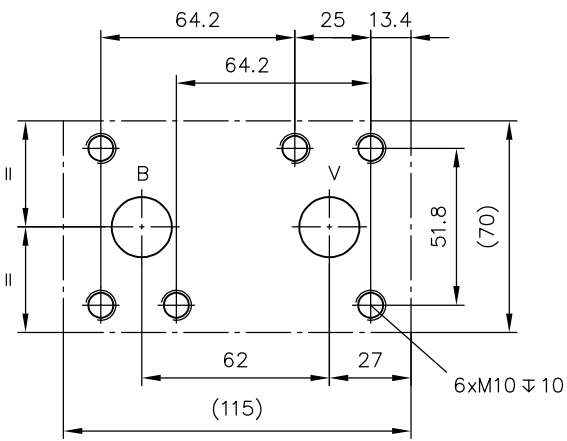

1 O-ring 26.64x2.62 NBR 90 Shore

LHK 33 -15, LHK 33 -15 C  
LHK 44 -15, LHK 44 -15 C

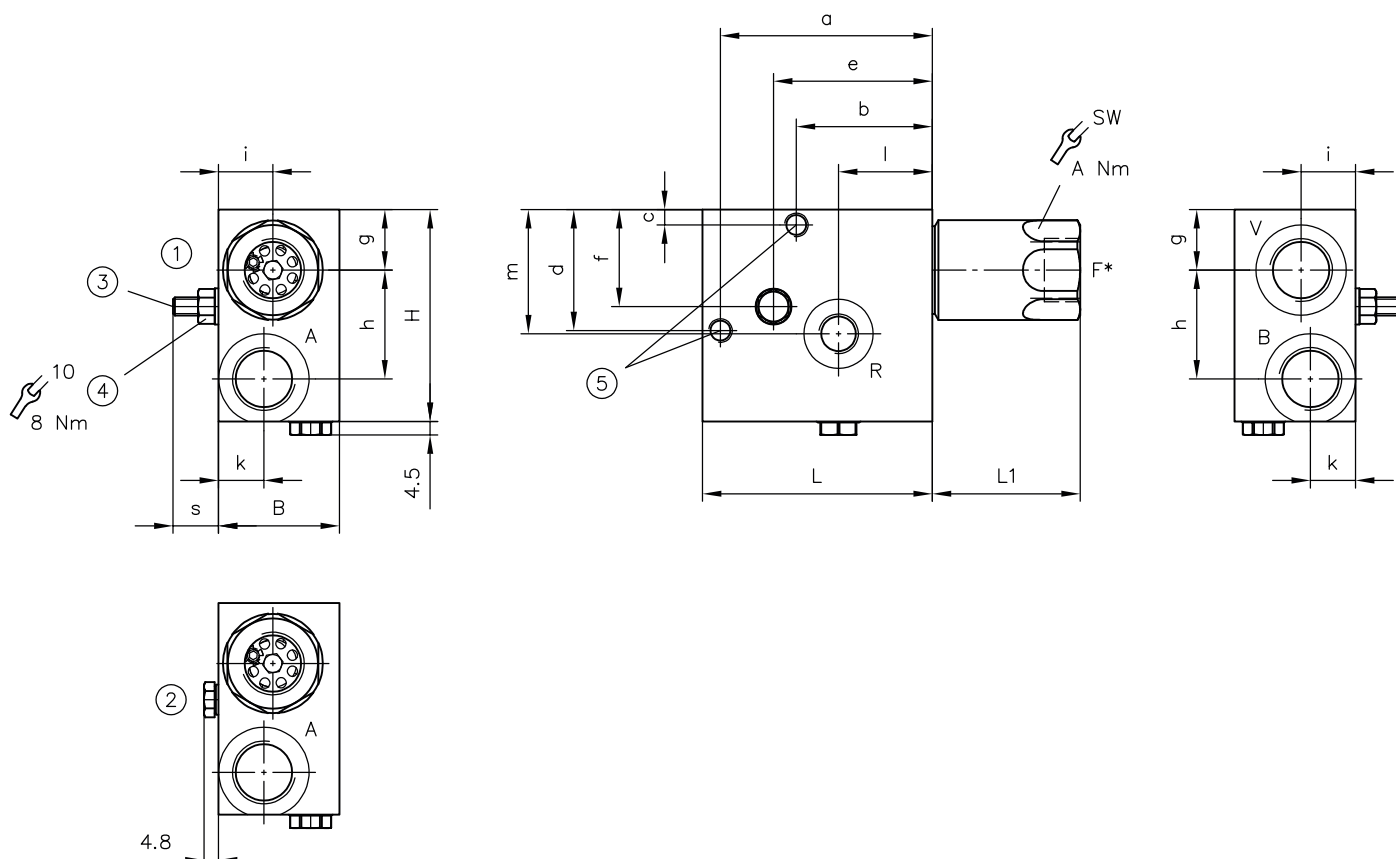

SW = Width across flats

- 1 With coding **G**: Check valve and throttle screw  
With coding **F**: Throttle screw, but no check valve (hole sealed)
- 2 With coding **U**: no check valve, no throttle screw (tapped plugs instead)
- 3 Grub screw SW3 (LHK 33) or hex bolt SW10 (LHK 44) for valve damping. Throttle effect increases clockwise.
- 4 Loosen the lock nut (seal-lock nut) sufficiently before adjusting the hex bolt, in order to prevent the thread from damaging the vulcanised sealing ring,
- 5 M8, 10 deep on both sides,  $\varnothing 6.8$  through

\* **NOTICE**  
When assembling the connection fittings, hold the hexagonal spring housing in place!

Type	L	L1	B	H	a	b	c	d	e	f	g	h	i	k
LHK 33 -15 LHK 33 -15 C	76	49	40	70	70	45	5	40	52.5	32	20	36	18	15
LHK 44 -15 LHK 44 -15 C	80	90	50	85	73	47	8	48	54.5	12	23	44	25	25

Type	l	m	s		SW	max. tightening torque (Nm)	Ports (ISO 228-1)	
			min	max			A	A, B, F, V R
LHK 33 -15 LHK 33 -15 C	31	41	13	22	30	160	G 1/2	G 1/4
LHK 44 -15 LHK 44 -15 C	37.5	53.5	19	28	36	180	G 3/4	G 1/4

**!** NOTICE

Do not unscrew the thread type throttle beyond  $S_{max}$ . Due to the design, it cannot be secured inside the device!

## 4.2 Valves for load direction change

LHK 22 -21, LHK 33 -21, LHK 44 -21

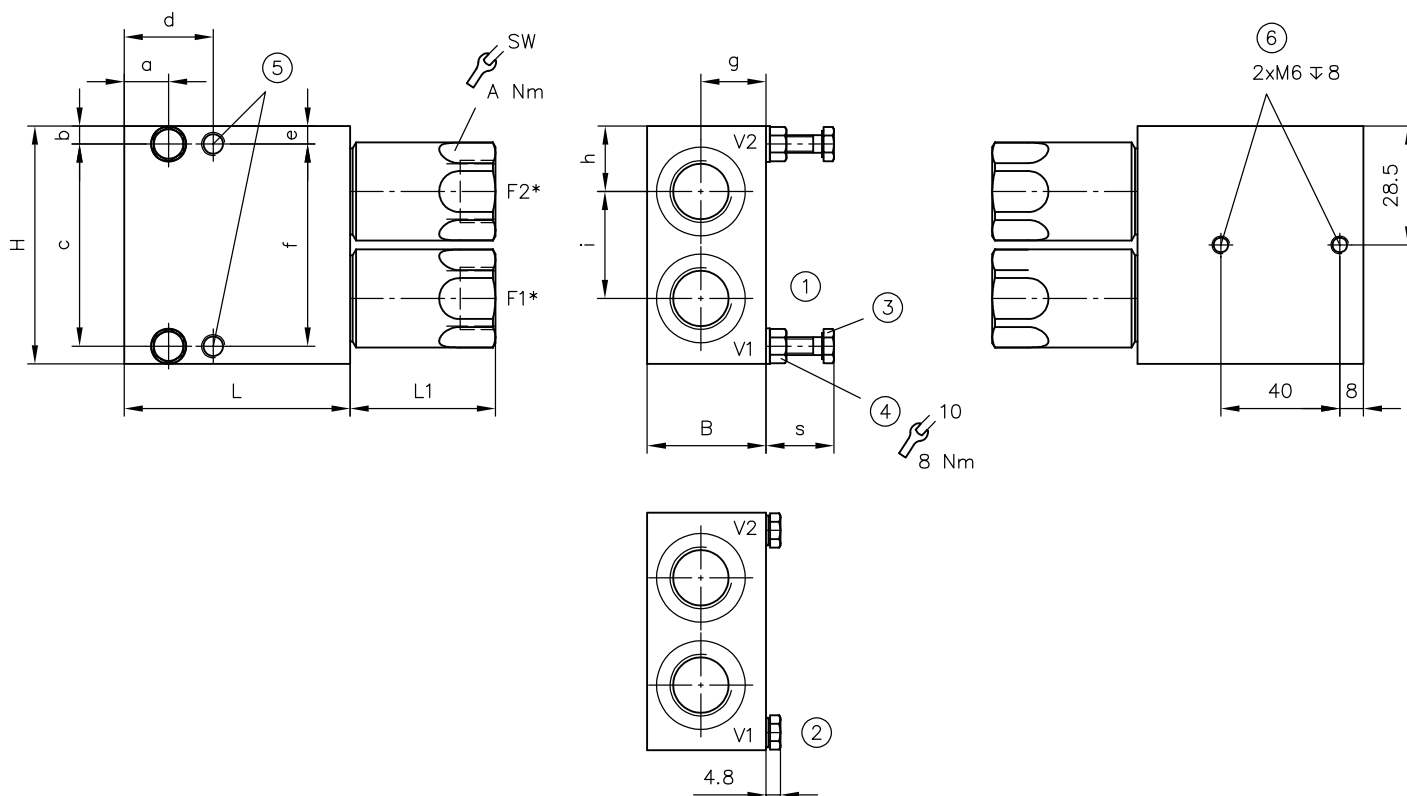

SW = Width across flats

- 1 With coding **G**: Check valve and throttle screw  
With coding **F**: Throttle screw, but no check valve (hole sealed)
- 2 With coding **U**: no check valve, no throttle screw (tapped plugs instead)
- 3 Grub screw SW3 (LHK 22) or hex bolt SW10 (LHK 33, LHK 44) for valve damping. Throttle effect increases clockwise.
- 4 Loosen the lock nut (seal-lock nut) sufficiently before adjusting the hex bolt, in order to prevent the thread from damaging the vulcanised sealing ring,
- 5 Type LHK 33 and LHK 44: M8, 10 deep on both sides; core hole  $\varnothing 6.8$  through with type LHK 33
- 6 only for type LHK 22

\* **NOTICE**  
When assembling the connection fittings, hold the hexagonal spring housing in place!

Type	L	L1	B	H	a	b	c	d	e	f	g	h	i
LHK 22 -21	58	40	30	60	21	6	48	--	--	--	16	16	28
LHK 33 -21	76	49	40	80	15	6	68	30	6	68	22	22	36
LHK 44 -21	80	90	50	90	15	5	80	30	7.5	75	25	44	44

Type	s		SW	max. tightening torque (Nm)	Ports (ISO 228-1)
	min	max			
LHK 22 -21	12	19	22	30	G 3/8
LHK 33 -21	15	25	30	160	G 1/2
LHK 44 -21	14	25	36	180	G 3/4

**!** NOTICE

Do not unscrew the thread type throttle beyond  $S_{max}$ . Due to the design, it cannot be secured inside the device!

LHK 33 -21 W  
LHK 44 -21 W

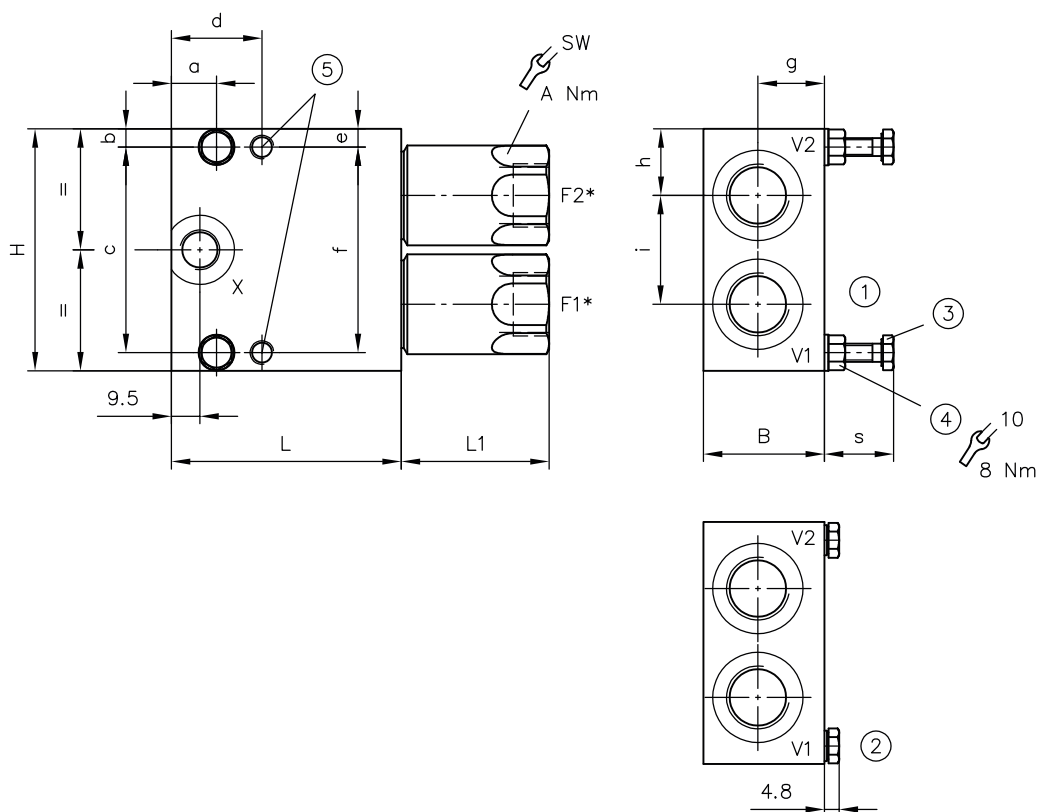

SW = Width across flats

- 1 With coding **G**: Check valve and throttle screw  
With coding **F**: Throttle screw, but no check valve (hole sealed)
- 2 With coding **U**: no check valve, no throttle screw (tapped plugs instead)
- 3 Grub screw SW3 (LHK 22) or hex bolt SW10 (LHK 33, LHK 44) for valve damping. Throttle effect increases clockwise.
- 4 Loosen the lock nut (seal-lock nut) sufficiently before adjusting the hex bolt, in order to prevent the thread from damaging the vulcanised sealing ring,
- 5 Type LHK 33 and LHK 44: M8, 10 deep on both sides; core hole  $\varnothing 6.8$  through with type LHK 33

\* **NOTICE**  
When assembling the connection fittings, hold the hexagonal spring housing in place!

Type	L	L1	B	H	a	b	c	d	e	f	g	h	i
LHK 33 -21 W	76	49	40	80	15	6	68	30	6	68	22	22	36
LHK 44 -21 W	80	90	50	90	15	5	80	30	7.5	75	25	23	44

Type	s		SW	max. tightening torque (Nm)	Ports (ISO 228-1)	
	min	max			A	X
LHK 33 -21 W	15	25	30	160	G 1/2	G 1/4
LHK 44 -21 W	14	25	36	180	G 3/4	G 1/4

\* **NOTICE**  
Do not unscrew the thread type throttle beyond  $S_{max}$ . Due to the design, it cannot be secured inside the device!

LHK 33 -25  
LHK 33 -25 W  
LHK 33 -25 WD

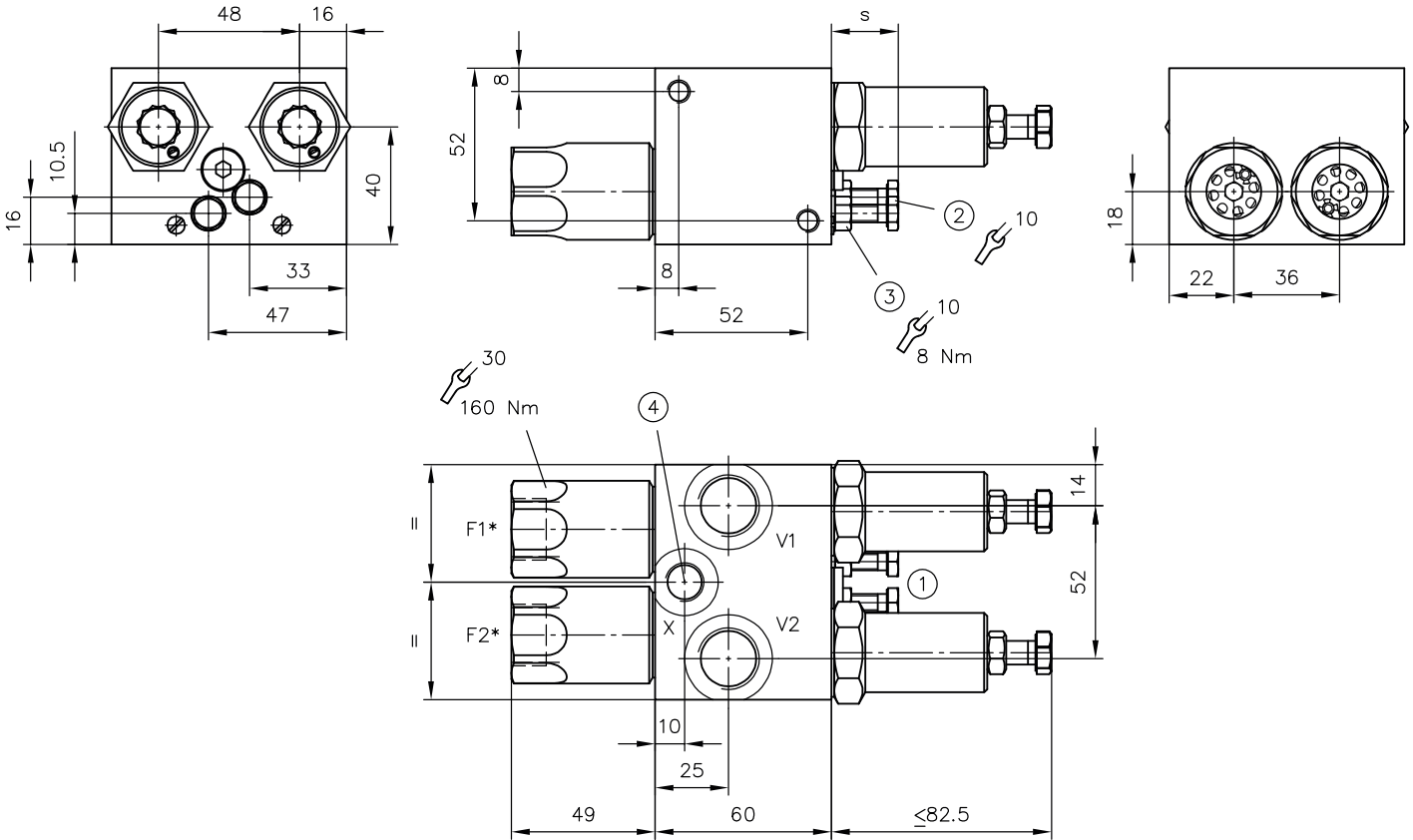

- 1 With coding **G**: Check valve and throttle screw
- 2 Hex bolt for valve damping. Throttle effect increases clockwise.
- 3 Loosen the lock nut (seal-lock nut) sufficiently before adjusting the hex bolt, in order to prevent the thread from damaging the vulcanised sealing ring,
- 4 only for type LHK 33 -25 W(WD)

\* **NOTICE**  
When assembling the connection fittings, hold the hexagonal spring housing in place!

Type	s		Ports (ISO 228-1)	
	min	max	F1, F2, V1, V2	X
LHK 33 -25				
LHK 33 -25 W	20	31	G 1/2	G 1/4
LHK 33 -25 WD				

\* **NOTICE**  
Do not unscrew the thread type throttle beyond  $S_{max}$ . Due to the design, it cannot be secured inside the device!

## 4.3 Load-holding valve inserts

### LHK 21, LHK 22

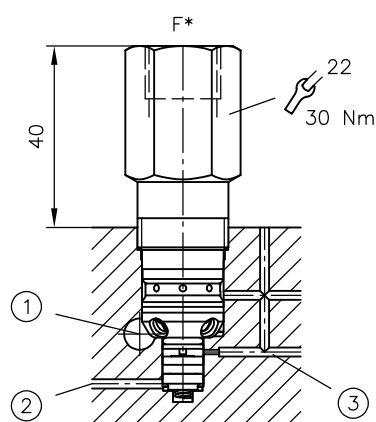

- 1 Consumer port V
- 2 Control port S
- 3 Connecting hole Y

\* **NOTICE**  
When assembling the connection fittings, hold the hexagonal spring housing in place!

Type	Ports (ISO 228-1)
	<b>F</b>
LHK 21	G 1/4
LHK 22	G 3/8

**Mounting hole**

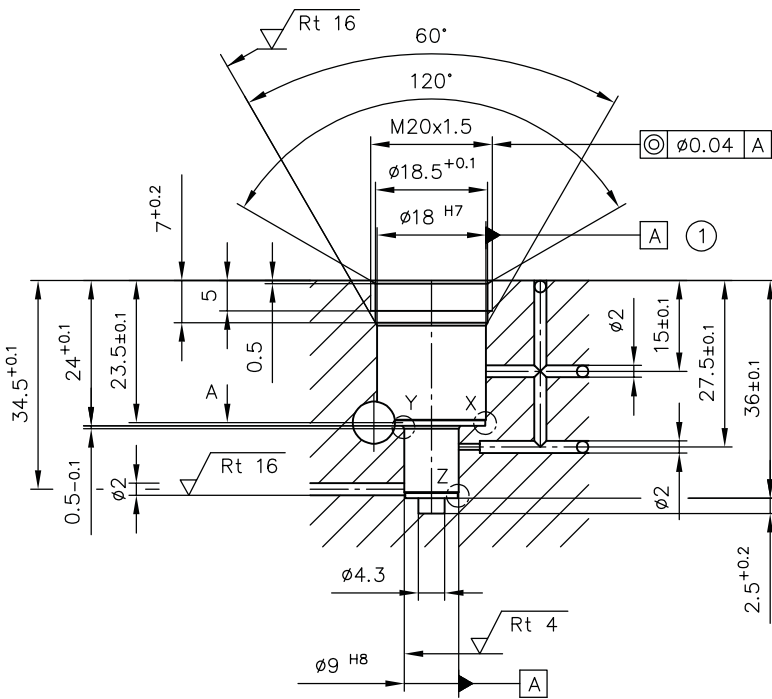

Partial cut A

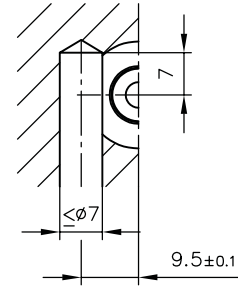

1 Do not damage the fit due to the thread!

Detail for X

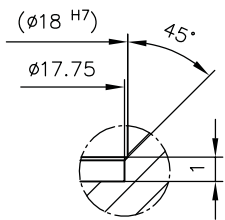

Detail for Y

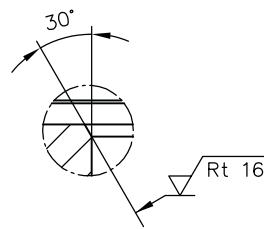

Detail for Z

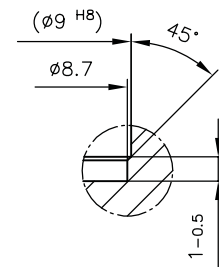

LHK 32, LHK 33

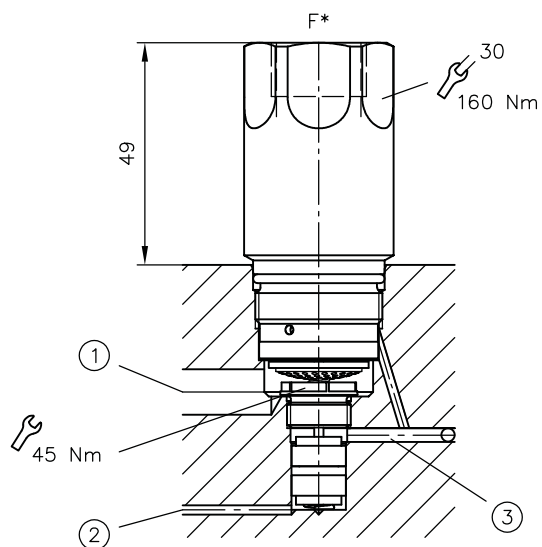

- 1 Consumer port V
- 2 Control port S
- 3 Connecting hole Y must meet the surface line between the specified depths.

\* **NOTICE**  
When assembling the connection fittings, hold the hexagonal spring housing in place!

Type	Ports (ISO 228-1)
	<b>F</b>
LHK 32	G 3/8
LHK 33	G 1/2

**Mounting hole**

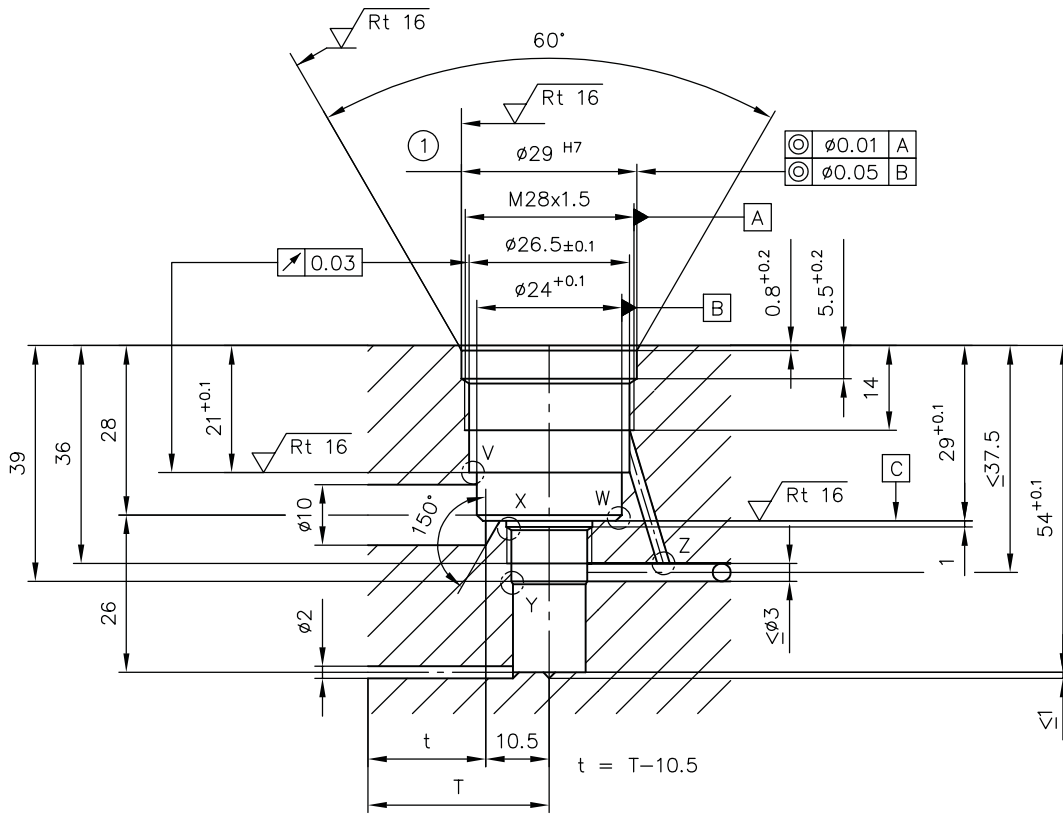

1 Reaming depth 5

Detail for V

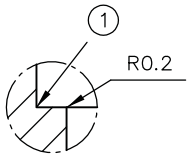

1 sharp-edged

Detail for W

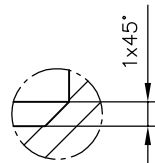

Detail for X

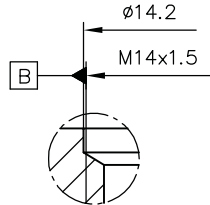

Detail for Z

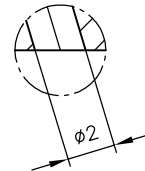

Detail for Y

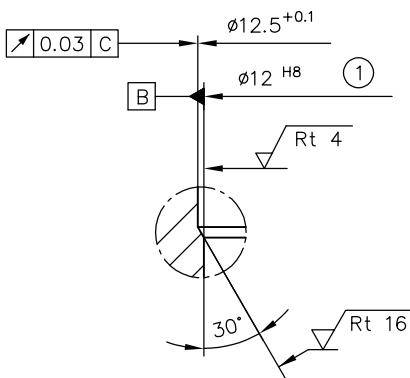

1 Reaming depth 53.5

LHK 44

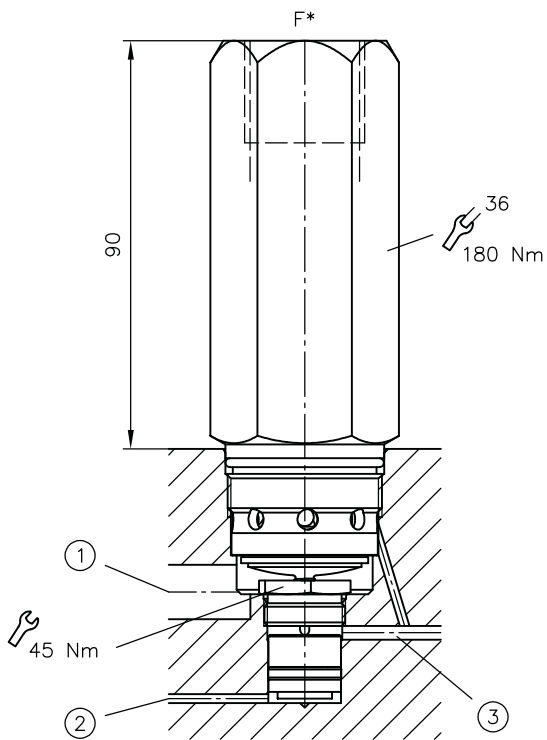

- 1 Consumer port V
- 2 Control port S
- 3 Connecting hole Y must meet the surface line between the specified depths.

\* **NOTICE**  
When assembling the connection fittings, hold the hexagonal spring housing in place!

	Port (ISO 228-1)
F	G 3/4

**Mounting hole**

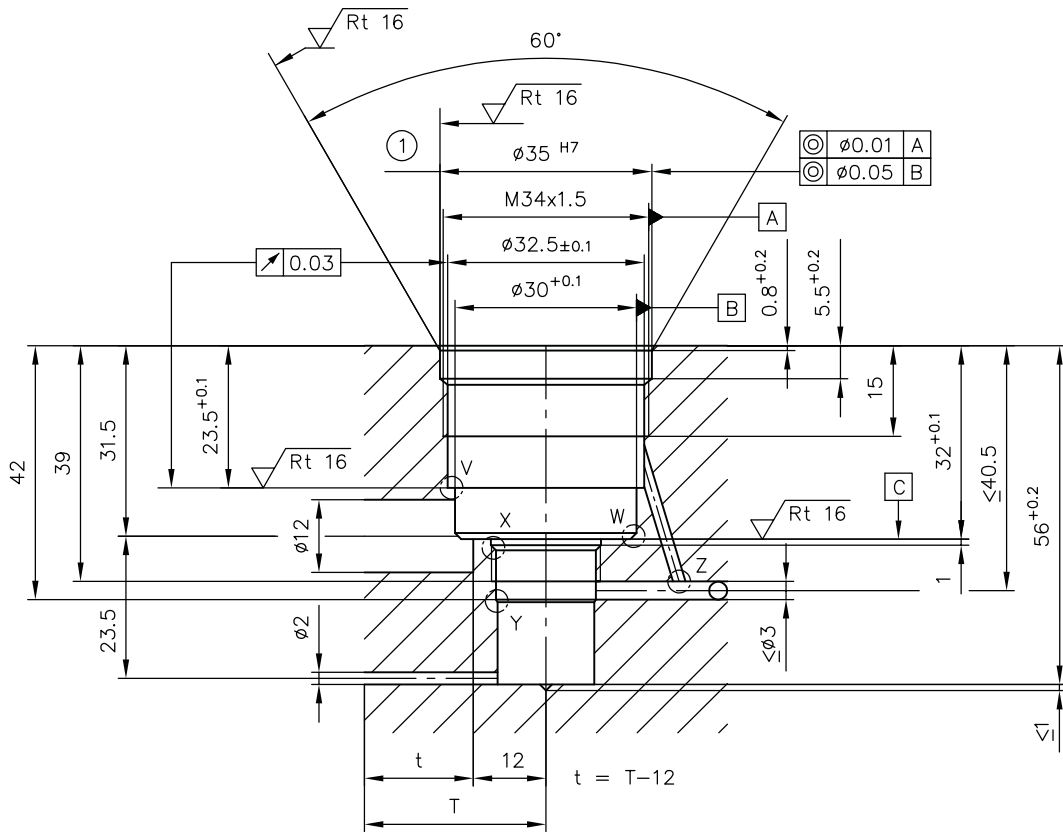

1 Reaming depth 5

Detail for V

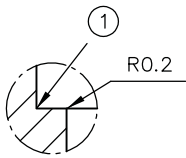

1 sharp-edged

Detail for W

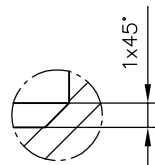

Detail for X

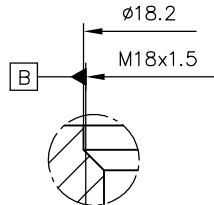

Detail for Z

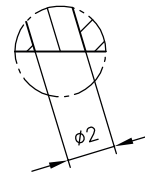

Detail for Y

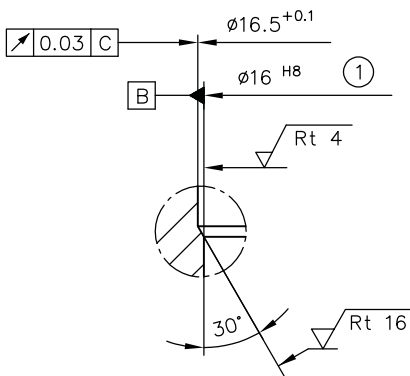

1 Reaming depth 55



LHK 30 V

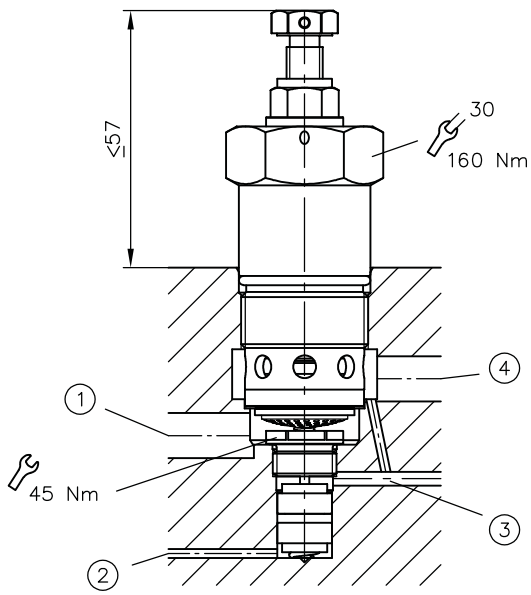

- 1 Consumer port V
- 2 Control port S
- 3 Connecting hole Y
- 4 Consumer port F



LHK 40 V

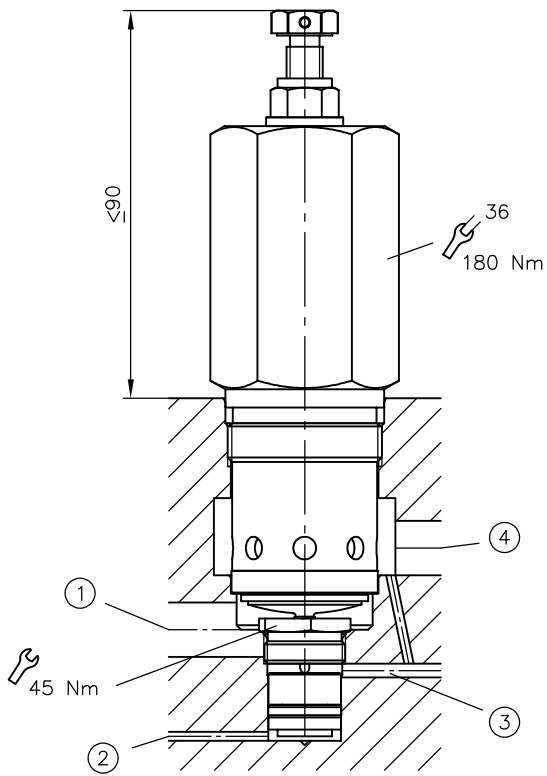

- 1 Consumer port V
- 2 Control port S
- 3 Connecting hole
- 4 Consumer port F

**Mounting hole**

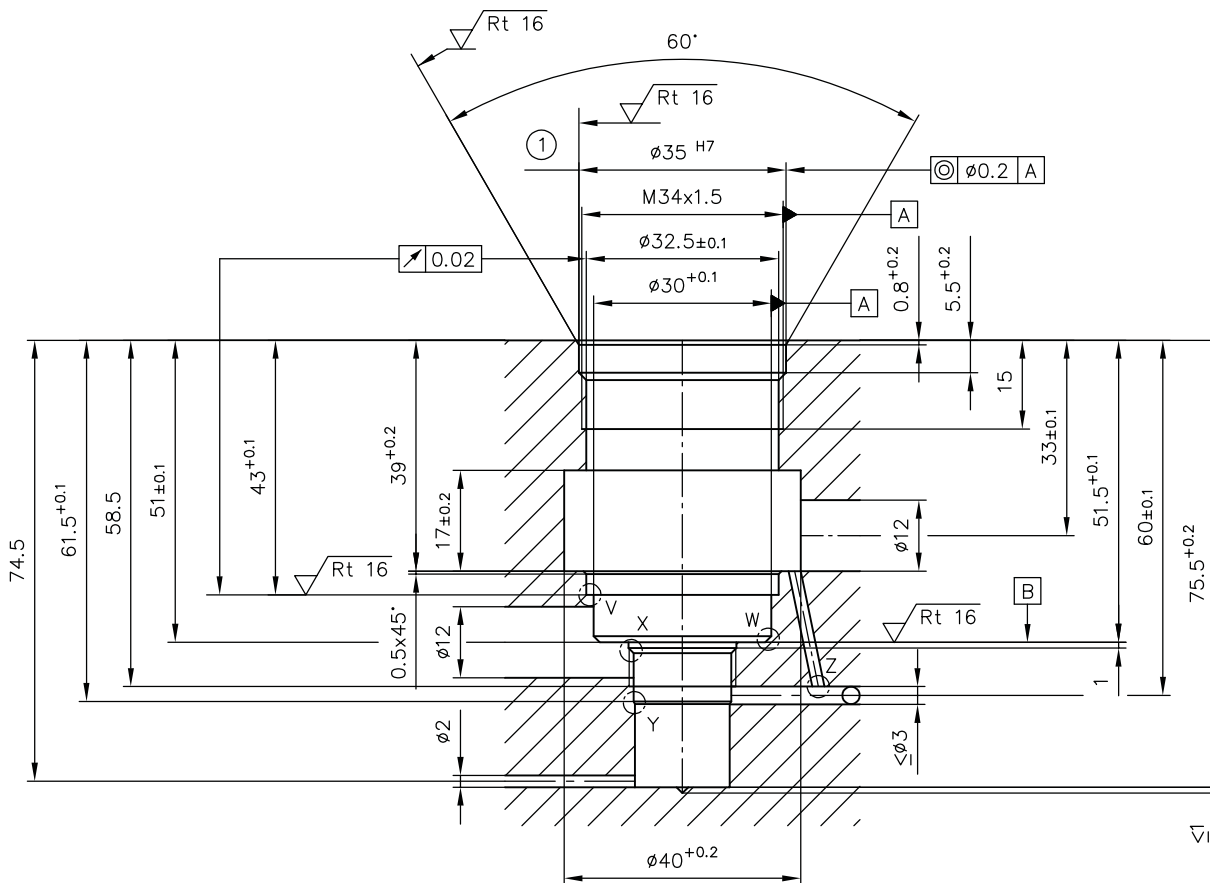

1 Reaming depth 5

Detail for V

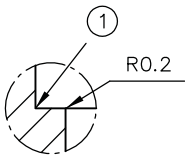

1 sharp-edged

Detail for W

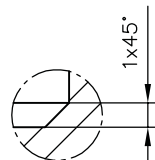

Detail for X

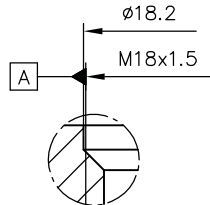

Detail for Z

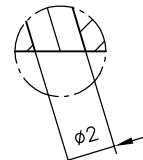

Detail for Y

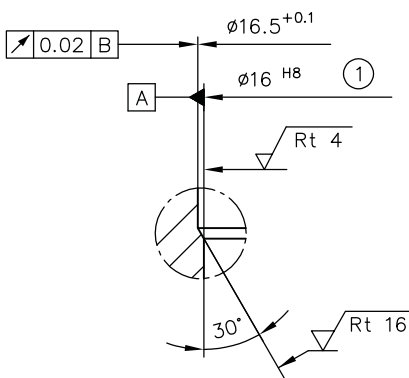

1 Reaming depth 74.5

LHK 33 S

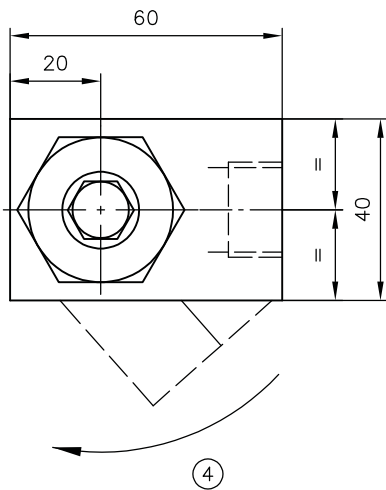
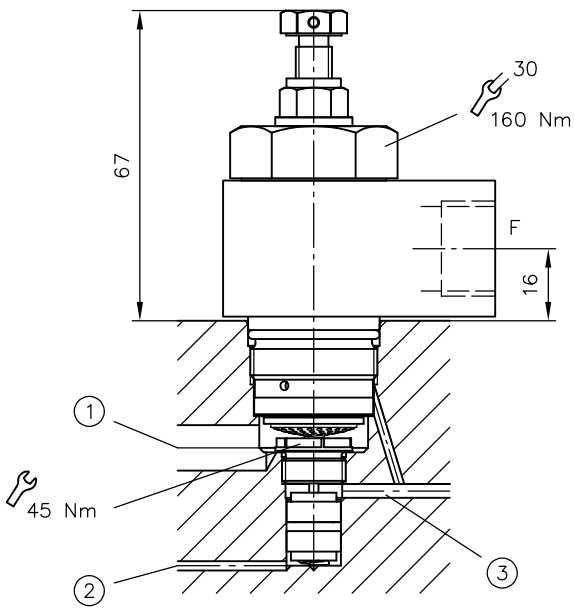

- 1 Consumer port V
- 2 Control port S
- 3 Connecting hole Y
- 4 can be swivelled 360° (cannot be used for combination with double-valve housings -21... and -25..., as the swivel part dimensions are too large)

**Port (ISO 228-1**

F	G 1/2
---	-------



Observe the document B 5488 "General operating instructions for assembly, commissioning, and maintenance."

### 5.1 Intended use

This product is intended exclusively for hydraulic applications (fluid technology).

The user must observe the safety measures and warnings in this document.

#### Essential requirements for the product to function correctly and safely:

- ▶ All information in this documentation must be observed. This applies in particular to all safety measures and warnings.
- ▶ The product must only be assembled and put into operation by specialist personnel.
- ▶ The product must only be operated within the specified technical parameters described in detail in this document.
- ▶ All components must be suitable for the operating conditions when using an assembly.
- ▶ The operating instructions for the components, assemblies and the specific complete system must also always be observed.

#### If the product can no longer be operated safely:

1. Remove the product from operation and mark it accordingly.
  - ✓ It is then not permitted to continue using or operating the product.

### 5.2 Assembly information

The product must only be installed in the complete system with standard and compliant connection components (screw fittings, hoses, pipes, fixtures etc.).

The product must be shut down correctly prior to disassembly (in particular in combination with hydraulic accumulators).

#### DANGER

##### Sudden movement of the hydraulic drives when disassembled incorrectly

Risk of serious injury or death

- ▶ Depressurise the hydraulic system.
- ▶ Perform safety measures in preparation for maintenance.

### 5.3 Operating instructions

Observe product configuration and pressure/flow rate.

The statements and technical parameters in this document must be strictly observed.

The instructions for the complete technical system must also always be followed.

#### NOTICE

- ▶ Read the documentation carefully before usage.
- ▶ The documentation must be accessible to the operating and maintenance staff at all times.
- ▶ Keep documentation up to date after every addition or update.

#### DANGER

Risk of serious injury or death.

Protect load-holding valves from external influences and forces, otherwise the fastening screws or spring housing may come loose. This can cause the load to drop suddenly.

**⚠ WARNING****Overloading components due to incorrect pressure settings.**

Risk of serious injury or death.

- Pay attention to the maximum operating pressure of the pump and the valves.
- Only trained personnel are permitted to set and change the pressure and they must always monitor the pressure gauge when doing so.

**Purity and filtering of the hydraulic fluid**

Fine contamination can significantly impair the function of the product. Contamination can cause irreparable damage.

**Examples of fine contamination include:**

- Swarf
- Rubber particles from hoses and seals
- Dirt due to assembly and maintenance
- Mechanical debris
- Chemical ageing of the hydraulic fluid

**! NOTICE****New hydraulic fluid from the manufacturer may not have the required purity.**

Damage to the product is possible.

- ▶ Filter new hydraulic fluid to a high quality when filling.
- ▶ Do not mix hydraulic fluids. Always use hydraulic fluid that is from the same manufacturer, of the same type, and with the same viscosity properties.

For smooth operation, pay attention to the cleanliness level of the hydraulic fluid (cleanliness level see Chapter 3, "Parameters").

Additionally applicable document: [D 5488/1](#) oil recommendations

**5.4 Maintenance information**

Check regularly (at least once a year) by visual inspection whether the hydraulic connections are damaged. If external leakages are found, shut down and repair the system.

Clean the surface of the device regularly (at least once a year) (dust deposits and dirt).

## 6 Other information

### 6.1 Pressure setting

**⚠ WARNING**

**Overloading components due to incorrect pressure settings.**

Risk of serious injury or death.

- Pay attention to the maximum operating pressure of the pump and the valves.
- Only trained personnel are permitted to set and change the pressure and they must always monitor the pressure gauge when doing so.

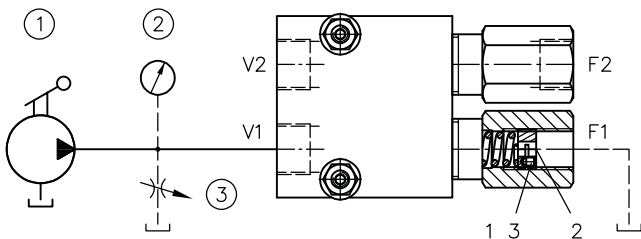

- 1 Hand-pump test bench
  - 2 Pressure gauge
  - 3 Bypass throttle valve required in the case of a motor pump test bench!
- Set pump to idle circulation via opened throttle valve, then slowly close throttle valve until the load-holding valve just barely responds (avoid larger flow rates, as the valve will otherwise squeak).

**Setting the pressure:**

1. Undo the headless screw (anti-adjustment guard of 2)
2. Adjust the washer with hex wrench

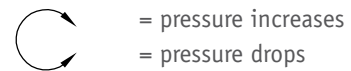

3. After making the setting:  
Re-tighten the headless screw **1**

The specified pressure change values per revolution or per millimetre of adjustment travel at the washer in port F (F1 and F2) are only rough indicative values for approximately finding the desired operating pressure.

Type	Pressure $p_{max}$ (bar)	Pressure change approx.	
		per revolution (bar/rev)	per mm of travel (bar/mm)
LHK 20	200	18	18
LHK 21	200	55	45
LHK 22	200	24	18
	400	100	75
LHK 30	130	22	17
	320	24	19
	360	30	24
LHK 32	130	46	36
	320	62	46
LHK 33 LHK 337	130	63	36
	320	85	46
	360	87	48
LHK 40	130	31	25
	350	47	38
LHK 43 LHK 44	160	45	25
	350	70	38

Type	Pressure $p_{\max}$ (bar)	Pressure change approx.	
		per revolution (bar/rev)	per mm of travel (bar/mm)
LHK 447	200	72	40
	400	112	60

## 6.2 Circuit examples

### Simplified, typical crane control

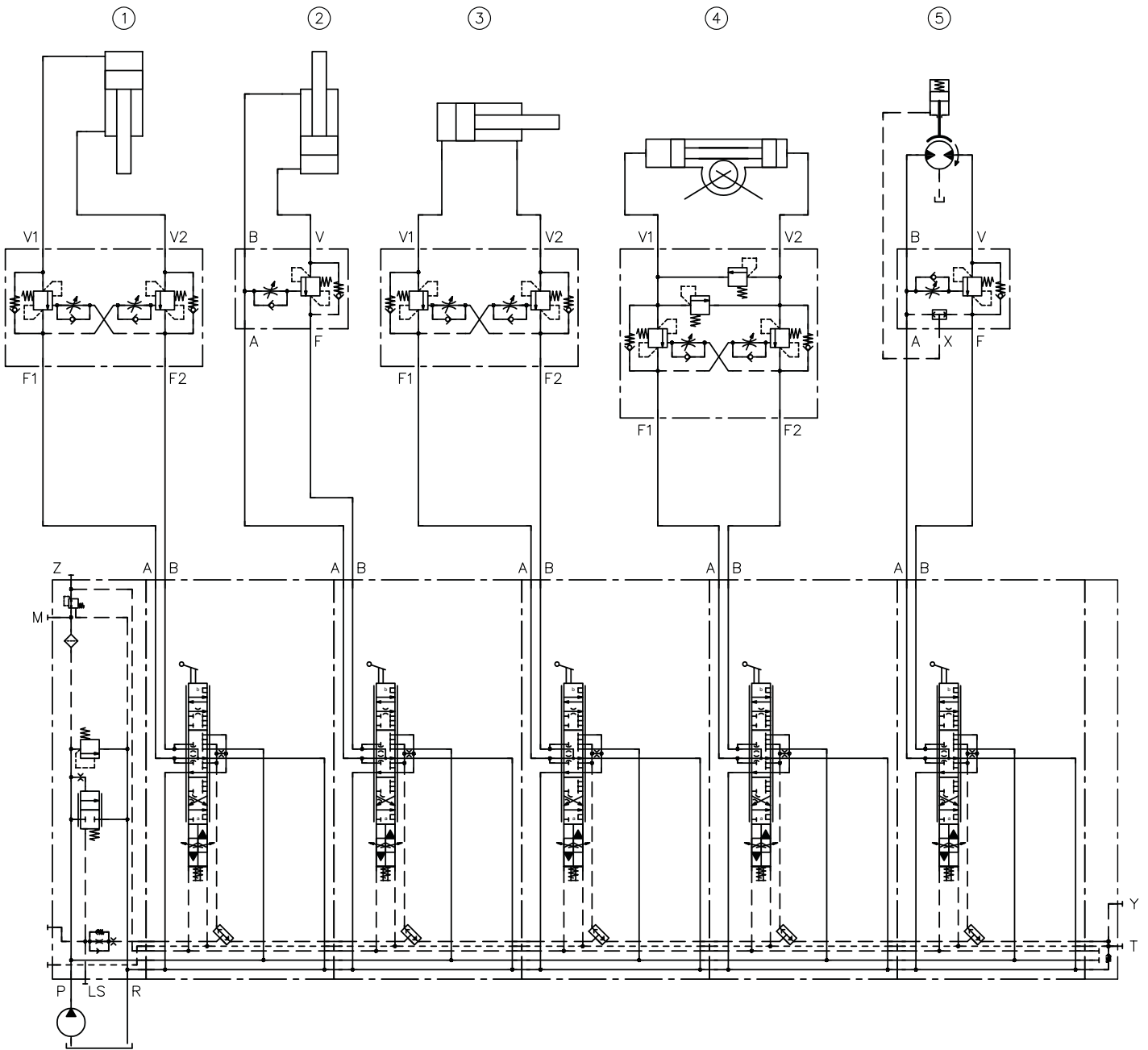

PSL 41/200 - 3	-31 O 40/25 / EA
	-31 O 63/40 / EA
	-31 O 25/16 / EA
	-31 O 16/16 / EA
	-31 O 63/63 / EA
	-E4 - G 24

- 1 Support cylinder
- 2 Lifting cylinder
- 3 Extension cylinder
- 4 Slewing gear
- 5 Winch

Proportional directional spool valve type PSL as per [D 7700-3](#)

## Synchronous system

The load only acts in one direction. The lifting takes place simultaneously by means of the two sub-delivery flow streams of the pump; the lowering takes place against the load-holding valves, whereby the synchronization is again achieved via the continuous delivery of the subflows.

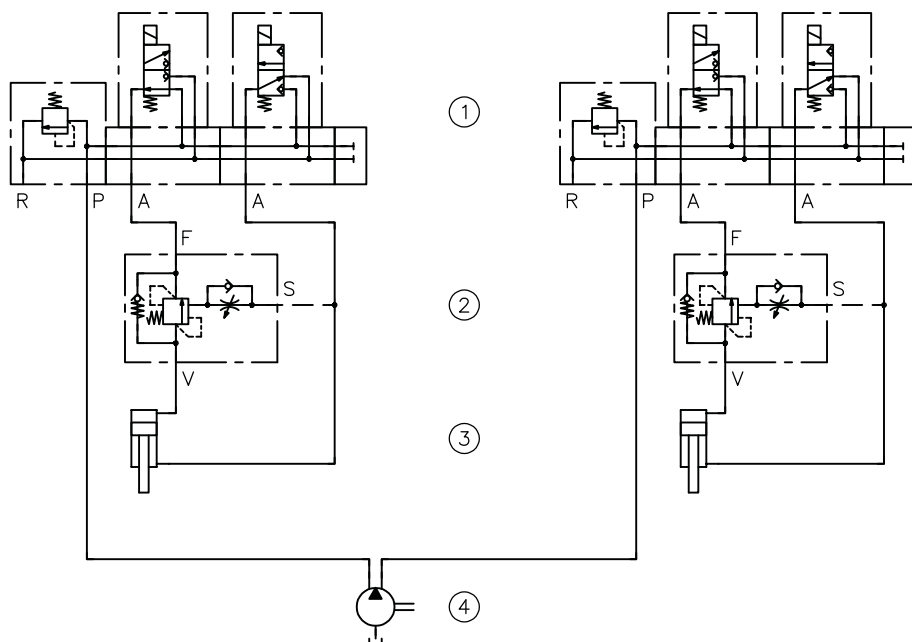

- 1 Valve banks e.g. type VB as per [D 7300](#) and [D 7302](#) or type BWH as per [D 7470 A/1](#) and [D 7470 B/1](#)
- 2 Load-holding valves  
e.g. LHK 33 G-11-... compensates for load differences during lowering to such an extent that the pump always encounters counter-pressure and the two subflows can fill the annular chambers evenly.
- 3 Lifting equipment with double-acting cylinders
- 4 Dual-circuit pump with two sub-delivery flow streams of equal size as per [D 6010 D](#)

Synchronous control systems in the version shown here are only a sensible choice if the demands on accuracy are not too high, and if disturbances in the synchronisation of the two delivery flow streams (e.g. incorrect switching of a solenoid valve, failure of a pump element due to contamination, etc.) are detected and the possible misalignment until switch-off does not result in danger to operating personnel and/or the system. Even during undisturbed operation, the synchronisation accuracy is influenced by factors such as the volume elasticity of the oil, the lines (especially hose lines = hose expansion), etc., depending on the load distribution. There is therefore basically no factory guarantee on the synchronization function of such systems.