

The series of pilot operated servo proportional valves D*1FP transfers the advantages of the Parker Voice Coil Drive (VCD) to larger frame sizes and thus high flow rates. The high dynamics / high precision drive of the pilot valve allows the optimum control of the main spool and results in servo class performance of the complete valves.

The D*1FP series is available in 4 sizes:

- D31FP NG10 (CETOP 05)
- D41FP NG16 (CETOP 07)
- D91FP NG25 (CETOP 08) for port diam. up to 32 mm
- D111FP NG32 (CETOP 10)

The safety concept works with a safe 4th position at the D1FP pilot valve. This ensures that the main stage is hydraulically balanced at power down and allows to have the main spool spring centered (for overlapped spools) or approximately 10 % spring offset to spool position A or B (for zerolap spools).



D31FP

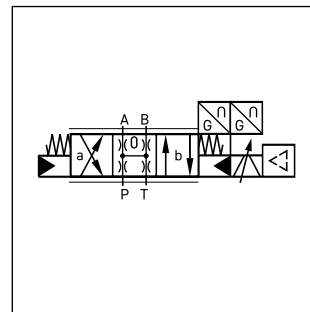

D*1FPE

3

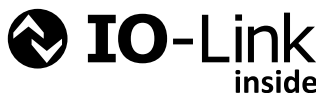

Features

- High dynamics
- High flow
- Defined spool positioning at power-down - optional P-A/B-T or P-B/A-T or center position (for overlapped spools)
- Onboard electronics
- IO-Link Class A parameterization and communication interface included as standard
- IO-Link Class B interface available
- RGB Diode diode for optical status check
- NFC interface
- Adjustable setpoint signal

D41FPE52

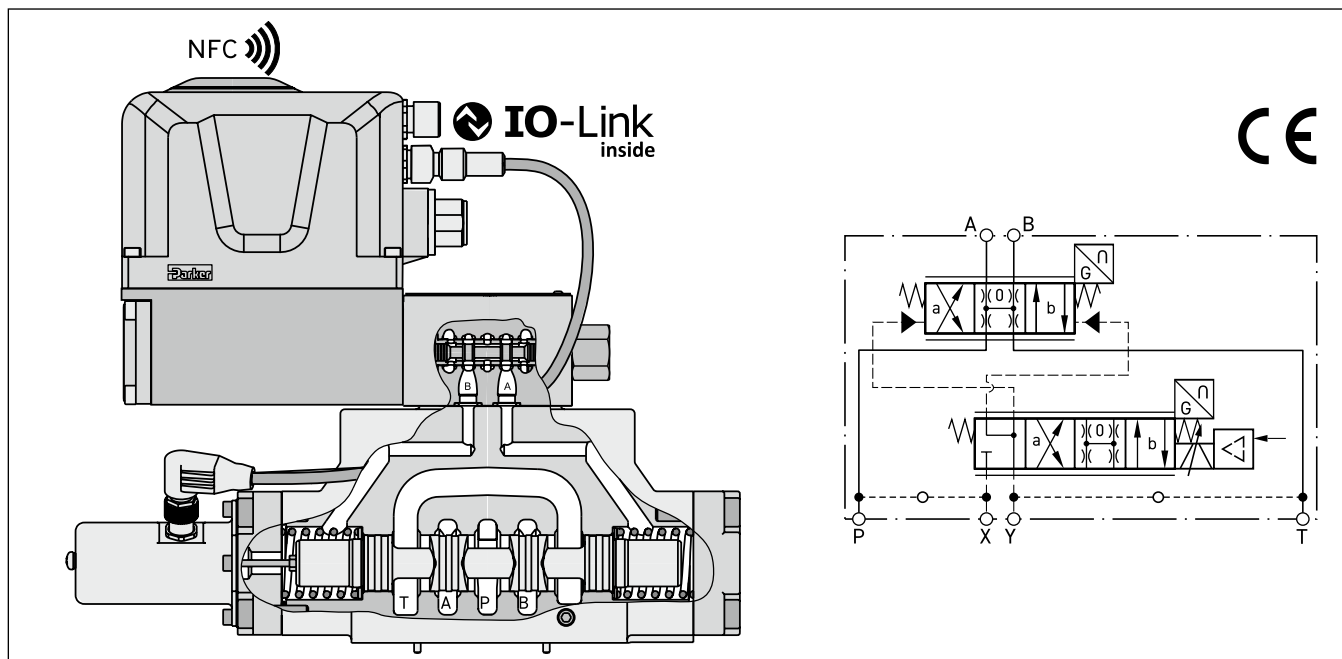

Ordering Code

3

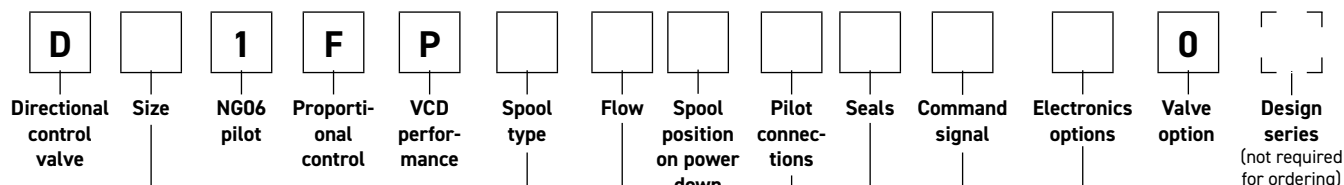

Code	Size
3	NG10 / CETOP 05
4	NG16 / CETOP 07
9 ¹⁾	NG25 / CETOP 08
11	NG32 / CETOP 10

Code	Spool type
overlap	
E01	
E02	
B31	$Q_b = Q_a / 2$
B32	$Q_b = Q_a / 2$
zerolap	
E52	
B61	$Q_b = Q_a / 2$

Code	Flow [l/min]			
	at $\Delta p = 5$ bar per metering edge			
	D31	D41	D91	D111
D	90	—	—	—
E	120	—	—	—
F	—	200	—	—
H	—	—	450	—
L	—	—	—	1000

Code	Command	Description
0	B; E; S; Y; W	6 + PE acc. EN175201-804
5	B; E; S; Y; W	11 + PE acc. EN175201-804
7	B; E; S; Y; W	6 + PE + Enable
0	I	IO-Link Class B

Code	Signal	Function
B	0...±10 V	0...+10 V -> P-A
E	0...±20 mA	0...+20 mA -> P-A
S	4...20 mA	12...20 mA -> P-A
Y	0...±50 mA	0...+20 mA -> P-A
W ⁴⁾	adjustable	Default +/-10V
I	IO-Link Class B	—

Code	Seals
N	NBR
V	FPM
H	for HFC fluid

Code	Inlet	Drain
1	internal	external
2	external	external
4	internal	internal
5	external	internal

Code	Spool pos. on power down
A ²⁾	
B ²⁾	
C ³⁾	

Short delivery time
for all variations

Please order connector separately. See chapter 3 accessories.

IO-LINK-MASTER-USB order no. 40983544

¹⁾ For enlarged connections $\varnothing 32$ mm.

²⁾ Approx. 10 % opening, only zero lapped spools.

³⁾ For overlapped spools.

⁴⁾ Available command signals – see technical data.

Technical Data

3

General					
Design		Pilot operated servo proportional DC valve			
Actuation		VCD-actuator			
Size		NG10 (CETOP 05)	NG16 (CETOP 07)	NG25 (CETOP 08)	NG32 (CETOP 10)
		D31	D41	D91	D111
Mounting Interface		DIN 24340 / ISO 4401 / CETOP RP121 / NFPA			
Mounting position		unrestricted			
Ambient temperature		-20...+60 [°C]			
MTTF _D value ¹⁾		75 [years]			
Weight		11.3	14.2	23.5	64.5
Vibration resistance		10 Sinus 5...2000 Hz acc. IEC 60068-2-6 20 (RMS) Random noise 20...2000 Hz acc. IEC 60068-2-64 15 Shock acc. IEC 60068-2-27			
Hydraulic					
Max. operating pressure		Internal pilot drain P, A, B, X 350; T, Y 35 ; External pilot drain P, A, B, T, X 350; Y 35			
Fluid		Hydraulic oil according to DIN 51524 ... 535, other on request			
Fluid temperature		-20...+60 (NBR: -25...+60) [°C]			
Viscosity permitted		20...400 [cSt]/[mm²/s]			
Viscosity recommended		30...80 [cSt]/[mm²/s]			
Filtration		ISO 4406; 18/16/13			
Nominal flow at Δp = 5 bar per control edge ²⁾		120	200	450	1000
Max. recommended flow (standard)		250	600	1000	3000
Leakage at 100 bar		200	200	600	1000
Overlapped spool		900	900	1000	5000
Zerolapped spool		< 500 [ml/min]			
Pilot		set to 10 command signal (see flow characteristics)			
Opening point		20...350 [bar]			
Pilot supply pressure		10			
Pilot flow during step response at 210 bar		12	24	40	
Static / Dynamic					
Step response at 100 % stroke ³⁾		10	13	19	45
Frequency response		128	95	95	40
Amplitude ±5 % at 210 bar		118	95	90	75
Phase ±5 % at 210 bar		< 0.1 [%]			
Hysteresis		< 0.05 [%]			
Sensitivity		< 0.025 [%/K]			
Temperature drift of center position					
Interfaces					
IO-Link		IEC 61131-9			
NFC ISO/IEC 15693		NFC Forum Type 5 tag certified by the NFC Forum Frequency 13.56 MHz; -27.2 dBμA/m at 10 meters distance			
Electrical					
Duty ratio		100 [%]			
Protection class		IP65 in accordance with EN 60529 (with correctly mounted plug-in connector) 6 = Full protection against contact, dust tight 5 = Protection against water jets (nozzle) from any angle			
Supply voltage / ripple		24 nominal (tolerance range 22 ... 30), electric shut-off at < 19, ripple < 5 % eff., surge free			
Current consumption max.		3.5 [A]			
Pre-fusing		4.0 A medium lag			
Command		Depending on choosen signal type			
Voltage		signal	10...0...-10, ripple <0.01 % eff., surge free		
impedance		100 [kOhm]			
Current		signal	20...0...-20, ripple <0.01 % eff., surge free		
impedance		<250 [Ohm]			
Current		signal	"4...12...20, ripple <0.01 % eff., surge free		
impedance		<250 [Ohm]			
Current		signal	10...0...-10, ripple <0.01 % eff., surge free		
impedance		<250 [Ohm]			
Current		signal	50...0...-50, ripple <0.01 % eff., surge free		
impedance		<250 [Ohm]			
Input Capacitance typ.		1 [nF]			
Differential input max.		Code 0	30 for terminal D and E against PE (terminal G)		
		Code 5	11 for terminal D and E against 0V (terminal B)		
		Code 7	30 for terminal 4 and 5 against PE (terminal ↓)		
Enable signal		Code 5/7	11 for terminal 4 and 5 against 0V (terminal 2)		
			30 for terminal D and E against PE (terminal G)		
Diagnostic signal		acc. EN 61131-2; Type 3			
EMC		Low -3...+5; High 11...30; input current 3 mA			
Electrical connection		+10...0...-10; 4...12...20 (max. 5mA)			
		EN 61000-6-2, EN 61000-6-4			
Wiring min.		Code 0/7	6 + PE acc. EN 175201-804		
		Code 5	11 + PE acc. EN 175201-804		
Wiring length max.		Code 0/7	7 x 1.0 (AWG16) overall braid shield		
		Code 5	8 x 1.0 (AWG16) overall braid shield		

¹⁾ If valves with onboard electronics are used in safety-related parts of control systems, in case the safety function is requested, the valve electronics voltage supply is to be switched off by a suitable switching element with sufficient reliability.

²⁾ Flow rate for different Δp per control edge: $Q_x = Q_{Nom.} \cdot \sqrt{\frac{\Delta p_x}{\Delta p_{Nom.}}}$

³⁾ Measured with load (210 bar pressure drop/two control edges).

Technical Data IO-Link Class B

3

Electrical characteristics		
Duty ratio	[%]	100
Protection class		IP65 in accordance with EN 60529 (with correctly mounted plug-in connector) 6 = Full protection against contact, dust tight 5 = Protection against water jets (nozzle) from any angle
Directive		IO-Link Interface and System Specification Version 1.1.2
Valve amplifiers Supply voltage/ripple	[V]	24 V nominal (tolerance range 22 ... 30V), electric shut-off at < 19, ripple < 5 % eff., surge free
Valve amplifiers max. power consumption	[A]	3.5
Valve amplifiers Pre-fusing	[A]	4.0 medium lag
IO-Link Interface Supply voltage/ripple	[V]	24 V nominal (tolerance range 22 ... 30V), electric shut-off at < 19, ripple < 5 % eff., surge free
IO-Link Interface max. power consumption	[A]	1.2
Functional ground and screening		Provide via valve block
Required master port class		Class B
EMC		EN 61000-6-2, EN 61000-6-4
Electrical connection		M12 sensor/actuator connection line, 5-pole; M12 connector/bush, A-coded, without shield
Wiring min.	[mm ²]	0.34 mm ² for a cable length of up to 5 m
Wiring length max.	[m]	20

Block diagram

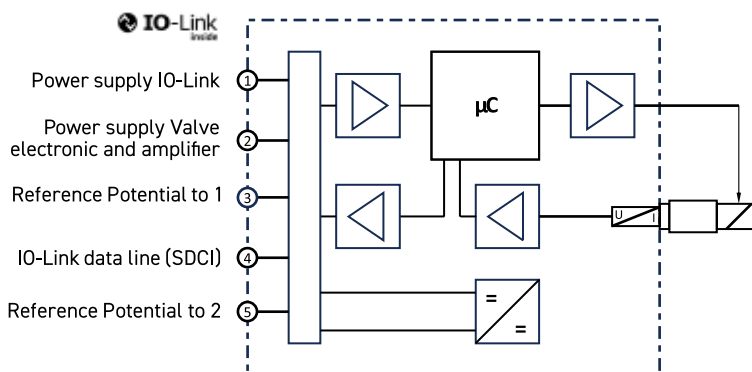

Pin	Signal	Signal - IO-Link B Class / viewing direction of the valve	
1	L+	Voltage Supply IO-Link	
2	P24	Voltage supply valve electronics and power part power consumption 4A	
3	L-	Reference potential pin 1	
4	C/Q	IO-Link data line (SDCI)	
5	N24	Reference potential pin 2	

Pin 3 and 5 are linked with each other in the valve electronics. The reference potentials L- and N24 of the two supply voltages must also be linked with each other on the power supply unit side.

Wiring

Code 0, 6 + PE acc. EN 175201-804

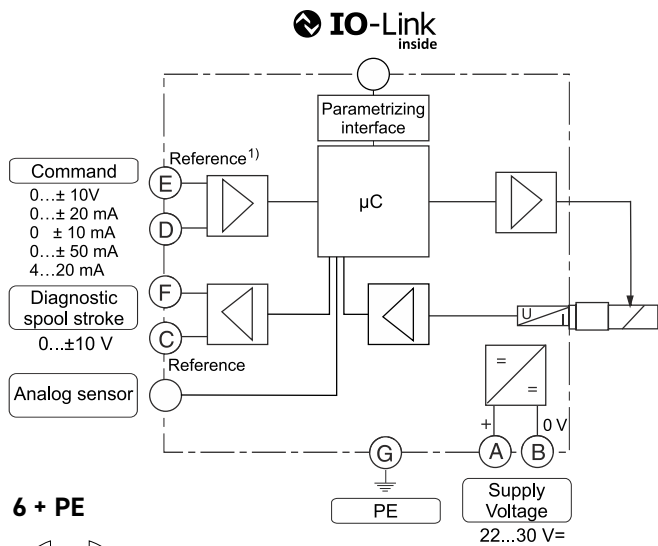

6 + PE

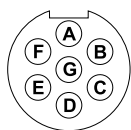

Code 5, 11 + PE acc. EN 175201-804

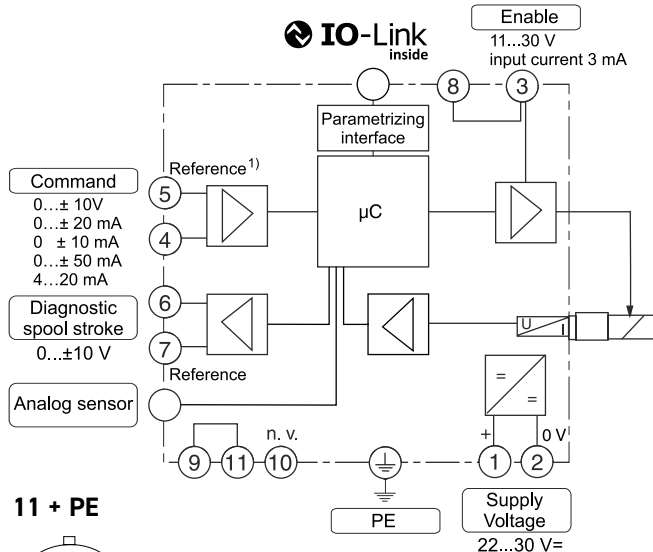

11 + PE

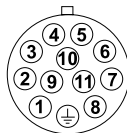

Code 7

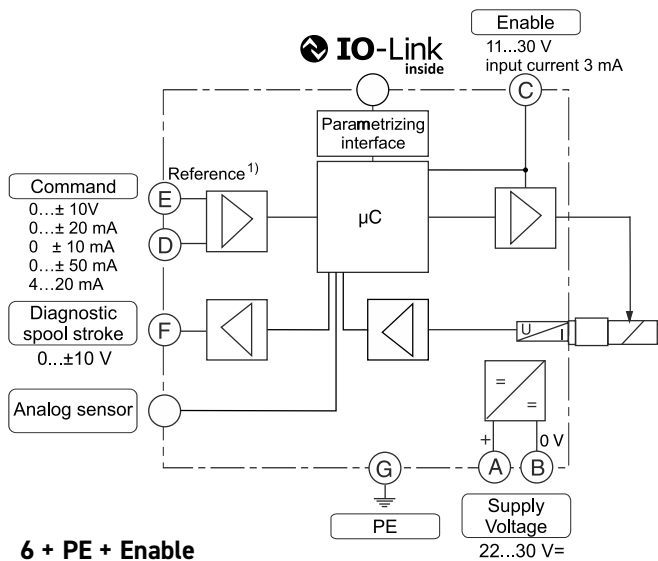

6 + PE + Enable

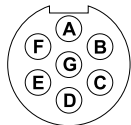

Pin assignment IO-Link (parametrizing) interface, M12 socket / viewing direction of the valve

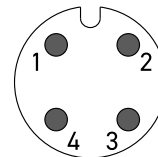

PIN assignment acc. IEC 60974-5-2

- Pin 1: 24 VDC
- Pin 3: GND
- Pin 4: IO-Link Communication (C/Q)

¹⁾ Do not connect with supply voltage zero.

3

IO-Link interface

IO Link communication and power supply is provided via the M12 interface, which is accessible from the outside. The IO Link interface allows external access to the available and accessible valve parameters via an IO Link Master or via the ProPxD software and the Parker IO-LINK MASTER USB.

For reliable parameterization of the valve, it is necessary to connect the power supply of the Parker IO-Link Master. It is not possible to operate the IO-Link B Class valve via the Parker IO-Link Master, as there is no power supply to the amplifiers.

Parker IO-LINK-MASTER-USB Best. Nr. 40983544
(Parameter overview in the operating instructions)

NFC-interface

The NFC interface allows a wireless access to valve data via the Parker APP Parker Device Control .

Available for free on the **App Store** and **Google Play Store**.

ProPxD parameterization software

The ProPxD software allows quick and easy setting of the digital valve electronics. Individual parameters as well as complete settings can be viewed, changed and saved via the comfortable user interface.

Parameter sets saved in the non-volatile memory can be loaded to other valves of the same type or saved for documentation purposes.

The PC software can be downloaded free of charge at www.parker.com/isde – see page "Support" or directly at www.parker.com/propxd.

3

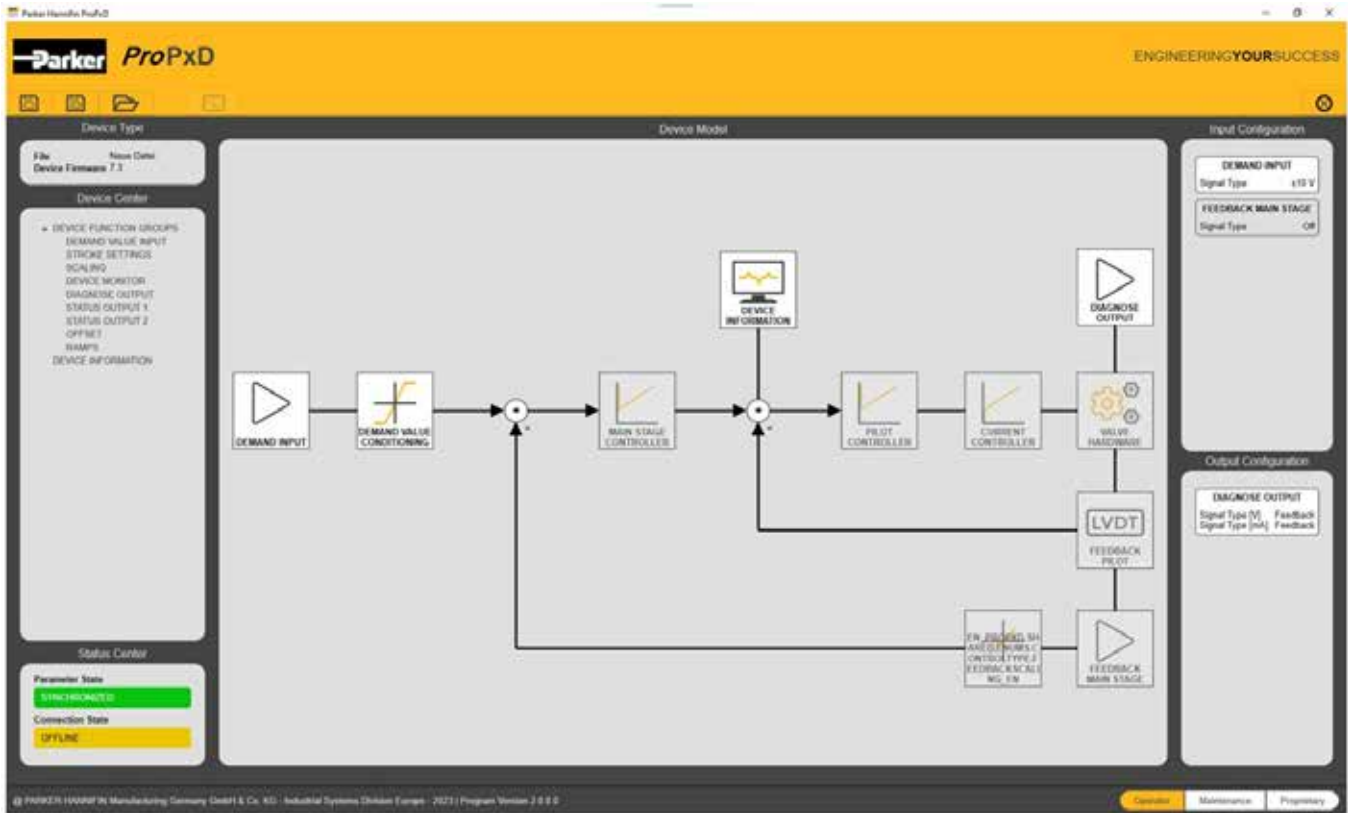

Frequency response

±5 % / ±25 % / ±90 % command signal
 Dynamics at 210 bar pilot supply pressure

D31FP

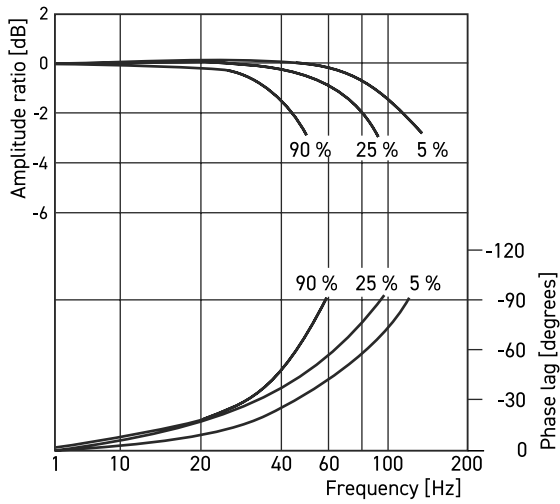

D41FP

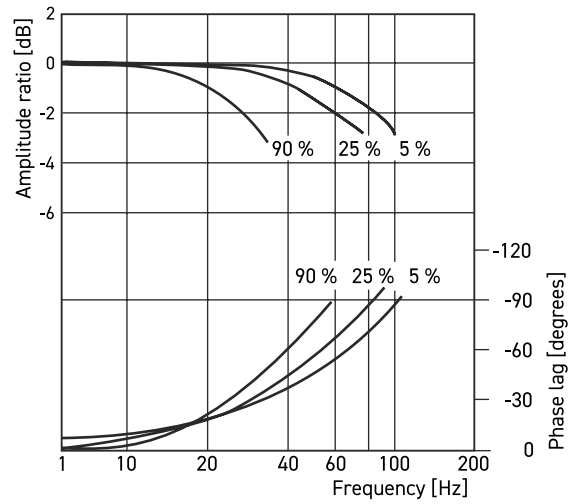

D91FP

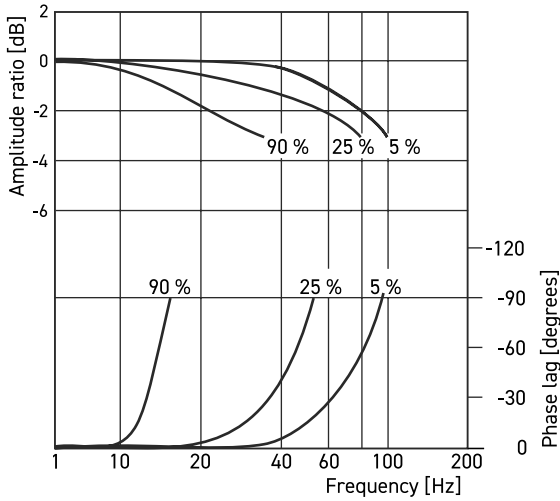

D111FP

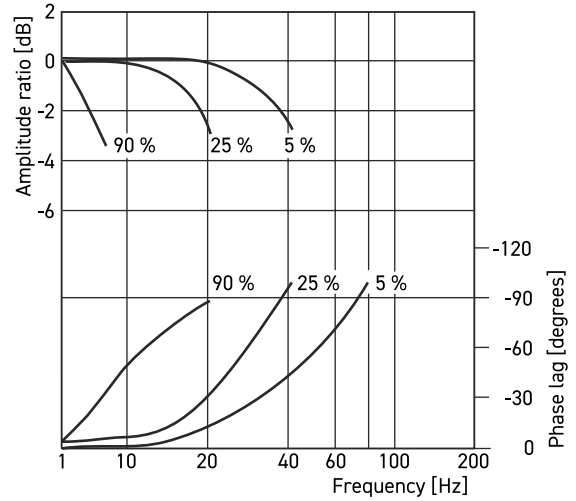

3

All characteristic curves measured with HLP46 at 50 °C.

D_1FP_UK.indd 13.04.26

Flow curves D*1FPB/E

(Overlapped spool set to opening point 10 %)
 at $\Delta p = 5$ bar per metering edge

D31FP

spool type E01/02/52, B31/32/61

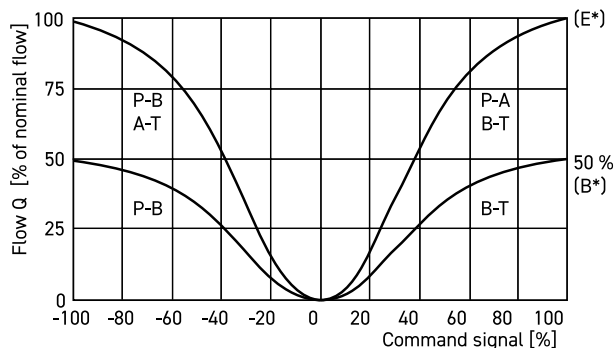

D41FP

spool type E01/02/52, B31/32/61

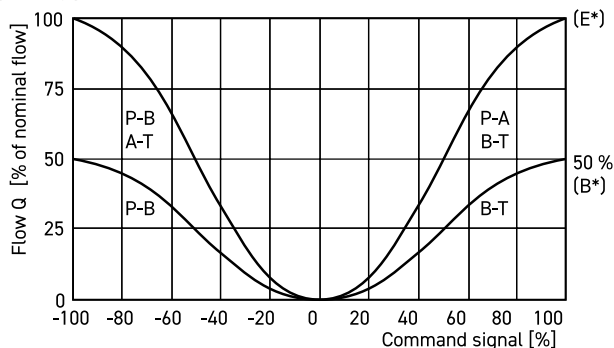

Flow curves

D91FP

Spool type E01/02/52, B31/32/61

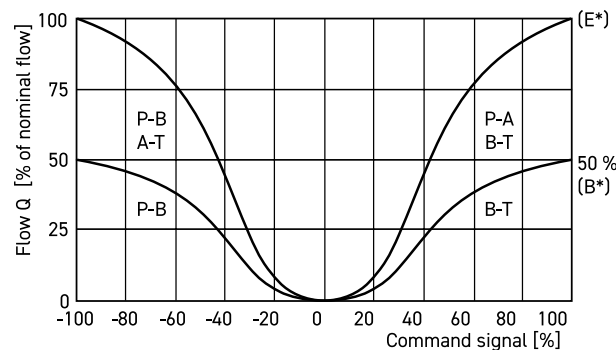

D111FP

Spool type E01/02/52, B31/32/61

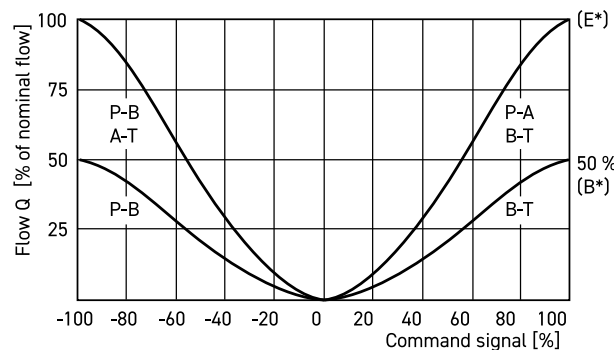

3

Pilot oil inlet (supply) and outlet (drain)

○ open, ● closed

Pilot oil		B	C
Inlet	Drain		
internal	external	○	●
external	external	●	●
internal	internal	○	○
external	internal	●	○

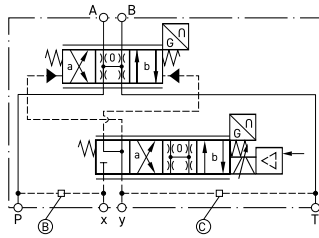

D31FPB/E

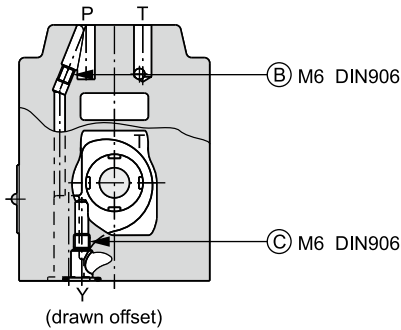

D41FPB/E

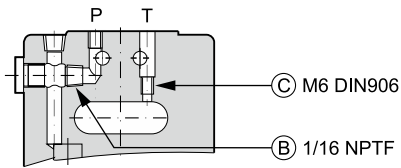

D91FPB/E

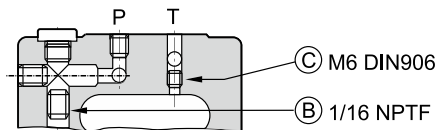



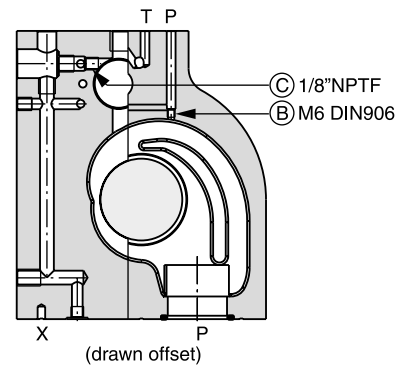
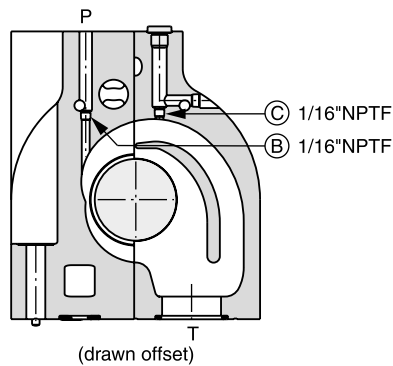
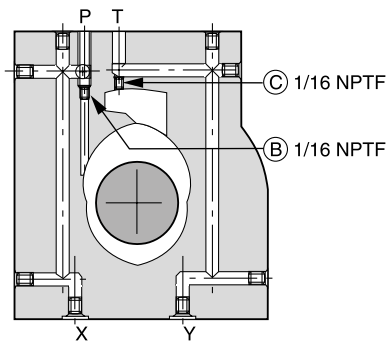

D111FPB/E

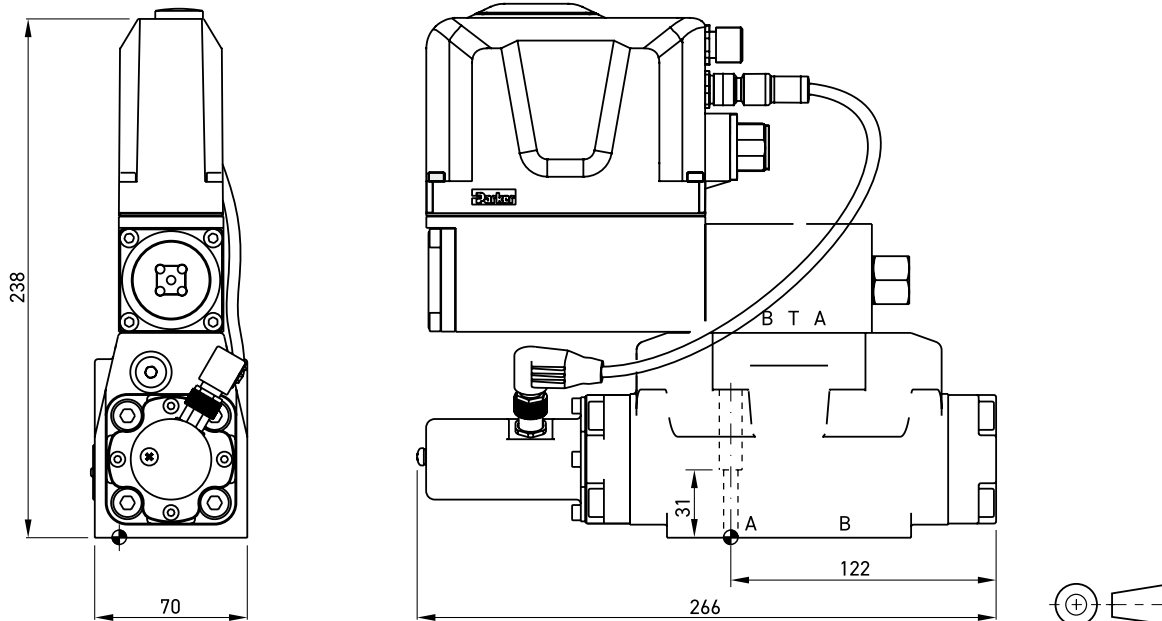

Dimensions



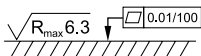

D31FP

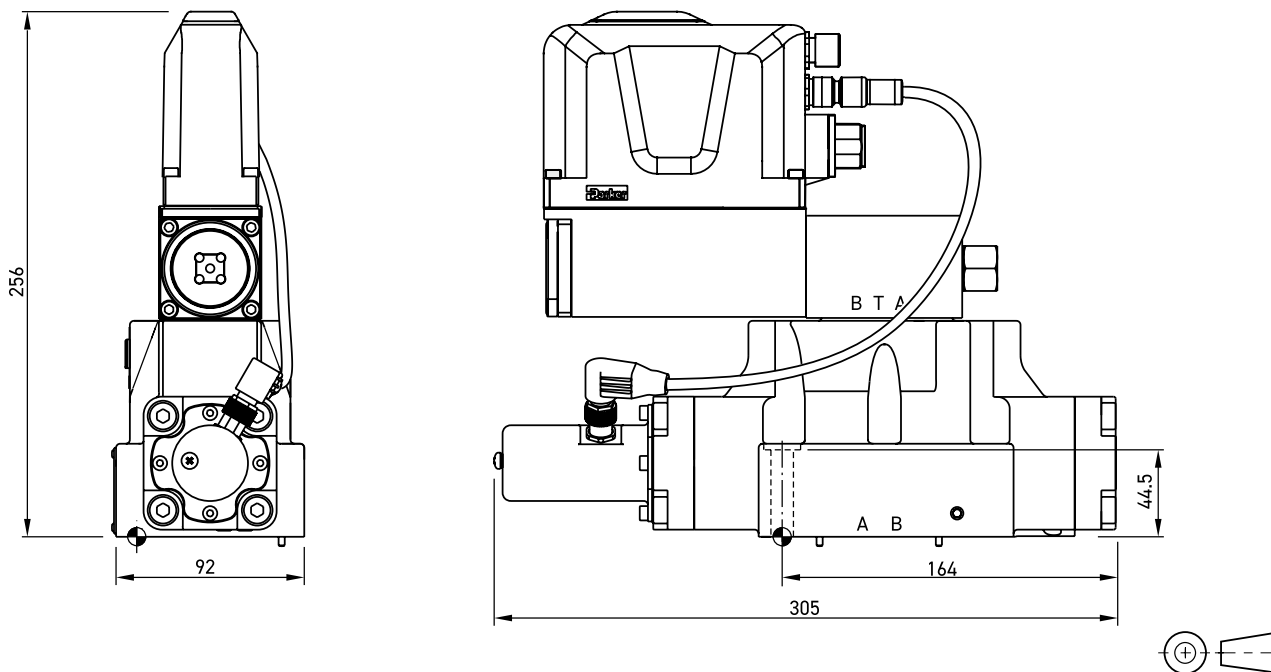

Surface finish	 Kit	 Kit	 Kit	 Kit
	BK385	4x M6x40 ISO 4762-12.9	13.2 Nm ±15 %	NBR: SK-D31FP FPM: SK-D31FP-V

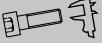
D41FP



Surface finish	 Kit	 Kit	 Kit	 Kit
	BK320	2x M6x55 4x M10x60 ISO 4762-12.9	13.2 Nm ±15 % 63 Nm ±15 %	NBR: SK-D41FP FPM: SK-D41FP-V

Dimensions

D91FP

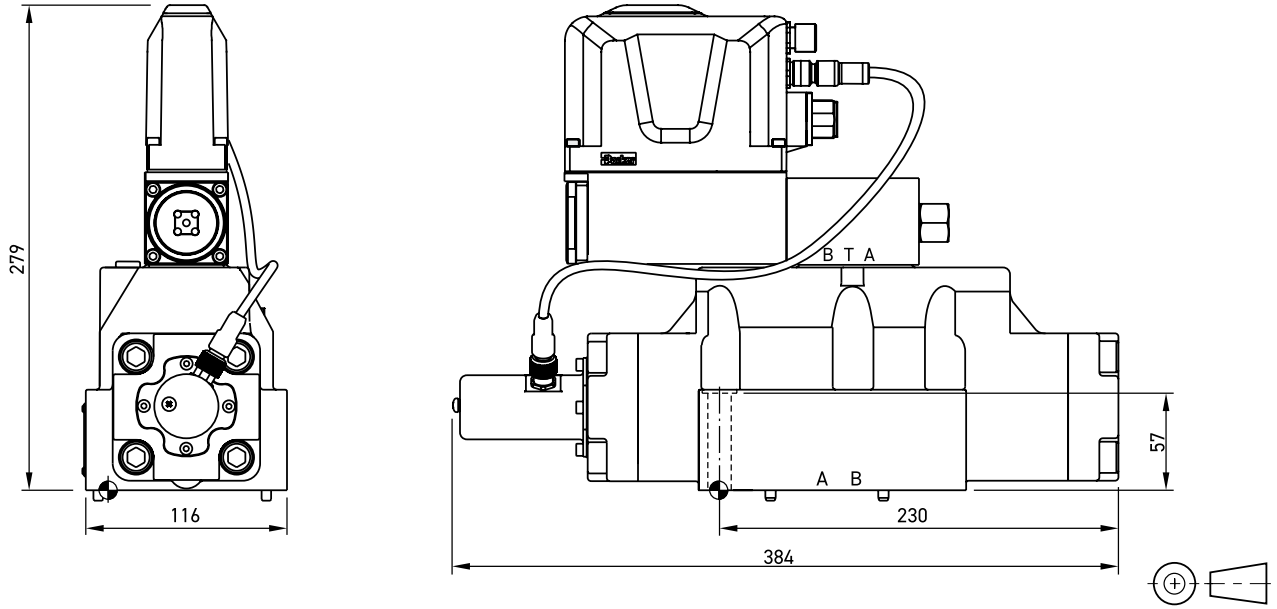

3

Surface finish	Kit	Kit	Kit	Kit
	BK360	6x M12x75 ISO 4762-12.9	108 Nm ±15 %	NBR: SK-D81/D91FP FPM: SK-D81/D91FP-V

D111FP

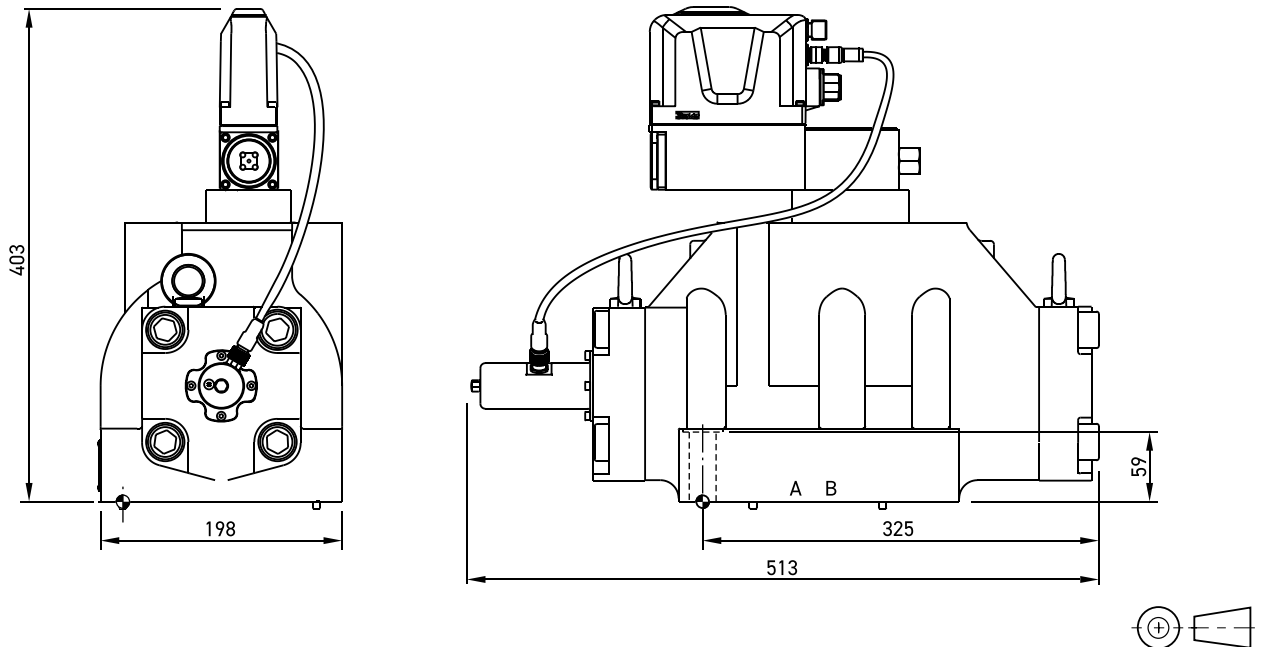

Surface finish	Kit	Kit	Kit	Kit
	BK386	6x M20x90 ISO 4762-12.9	517 Nm ±15 %	NBR: SK-D111FP FPM: SK-D111FP-V