



Actuators for air and gas dampers

SQM45...
SQM48...

Electromotoric actuators

- **Torques:**
 - SQM45 up to 3 Nm
 - SQM48 up to 20 Nm
 - SQM48.6 up to 35 Nm
- **Running times: ¹⁾**
 - SQM45 10 ... 120 s
 - SQM48 30 ... 120 s
 - SQM48.6 60 ... 120 s
- **Versions:**
 - Choice of drive shafts (refer to «Type summary»)

¹⁾ Depending on the type of basic unit (LMV5)

The actuators SQM45 / SQM48 and this Data sheet are intended for use by OEMs which integrate the actuators in their products!

Use

The SQM45 / SQM48 actuators are suited for driving oil pressure controllers, butterfly valves, dampers or for use on other applications that require rotary motion.

Areas of application are oil and gas burners of medium to larger capacity, as well as thermal process plants.

The actuators are used primarily for the load-dependent control of the gas flow, oil volume and combustion air volume in connection with the electronic ratio control LMV5.

Supplementary documentation

Product type	Type of documentation	Documentation number
LMV5	Data Sheet	N7550
	Basic documentation	P7550
AZL5	User documentation	A7550

Warning notes



To avoid injury to persons, damage to property or the environment, the following warning notes must be observed!

Do not open, interfere with or modify the actuators!

- Read the documentation on the actuators carefully and fully. If not observed, dangerous situations can occur
- The user must ensure that the actuators meet the requirements of the relevant application standards
- Safety-related applications are only available with Siemens burner controls
- All product-related activities (mounting, settings and maintenance) must be performed by qualified and authorized personnel



Attention!

- **Risk of electric shock – to disconnect the equipment from the power, it may be necessary to open more than one switch. Before performing maintenance work, the equipment must be disconnected from power**
 - **The electrical connection between the conduit fittings is not made automatically. It must be established on installation site**
 - **The connecting plate is made of plastic and does not provide earthing of the conduit fittings. Earthing must be ensured by adequate washers and wire links.**
- To ensure protection against electric shock, the connection terminals must have adequate protection. Make certain that non-insulated connections or wires cannot be touched
 - Each time work has been carried out (mounting, installation, service work, etc.), check to ensure that wiring is in an orderly state
 - Fall or shock can adversely affect the safety functions. Such units must not be put into operation, even if they do not exhibit any damage
 - Static charges must be avoided since they can damage the electronic components on contact.
Recommended: Use ESD equipment

Notes on use in North America

Only flexible conduits with relevant accessories may be used.

Mounting notes

- Ensure that the relevant national safety regulations and notes on standards are complied with
- In the geographical areas where DIN regulations are in use, the requirements of VDE must be complied with, especially DIN/VDE 0100, 0550 and DIN/VDE 0722
- Make certain that the actuator is not exposed to direct solar radiation
- Required tightening torques for the fixing screws of the
 - housing cover: 3.5 Nm
 - connecting cover: 2 Nm
- The connection between actuator drive shaft and controlling element must be **flexible but torsionally rigid couplings with free from backlash**

Positive connection



Note!

Possible connection with drive shaft or hub:

- Groove with Woodruff key
- Drive shaft with flat edge and matching counter piece

To avoid inadmissible loads and moments by mechanical overload, appropriate actions must be taken at the mechanical coupling

Example: Metal bellows clutches as compensating clutches with no mechanical play

Cable and cable shielding

Only the specified cable may be used (refer to Basic Documentation P7550). The cable's shielding must be connected to the printed circuit board using the tab provided.



Warning!

Ensure that the actuator's housing is connected to functional earth (FE) of the system. If necessary, remove isolating layers of paint from the fixing points on the burner's casing or run separate earth wires. For detailed information, refer to «Installation Instructions for the LMV5 system» (J7550.1).

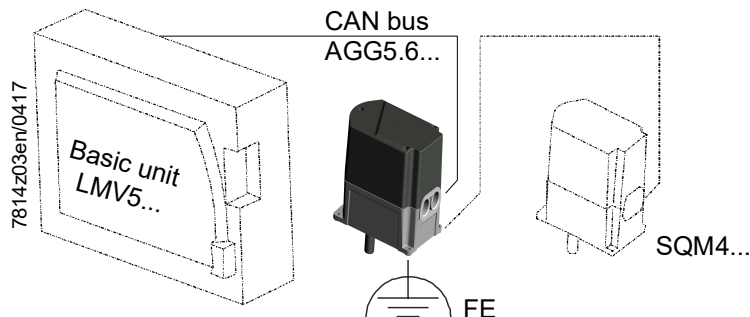

Working range of actuator

The working range is given on the type field and must be observed when mounting the actuator.

IP54

To ensure **degree of protection IP54**, suitable M16 glands must be fitted in the actuator's M16 openings. The M16 glands used must feature cable strain relief. To ensure degree of protection IP54 during the actuator's entire service life, the bearing of the drive shaft must be located such that it will not be directly exposed to water or dust.



Warning!

SQM45.xxxB9 / SQM48.xxxB9 must be installed at a sufficient distance from magnetic fields (e.g. permanent magnets, transformers, electric motors, etc.). With magnetic fields of ≤ 1000 mT, a minimum distance of 10 cm must be complied with. For stronger magnetic fields ($>1...10$ T), a minimum distance of 40 cm must be complied with.

Installation notes

- Ensure that the electrical wiring is in compliance with national and local regulations.
- Make certain that strain relief of the connected cables is in compliance with the relevant standards (e.g. as per DIN EN 60730 and DIN EN 60335)
- Ensure that spliced wires cannot come into contact with neighboring terminals. Use suitable ferrules
- In case of increased vibration requirements, the internal connector system must be additionally secured
- The connection between the actuator drive shaft and the relevant controlling element must be form-fitted
- The holding torque is reduced when the actuator's power supply is switched off

Housing cover



Warning!

The housing cover may only be removed for short periods of time for wiring or when making the addressing. It must be made certain that dust or dirt will not get inside the actuator while such work is carried out.

ESD



Warning!

The actuator contains a printed circuit board with ESD-sensitive components. The top side of the board carries a cover which affords protection against direct contact. This protective cover must not be removed! The underside side of the board must not be touched.

Protective cover

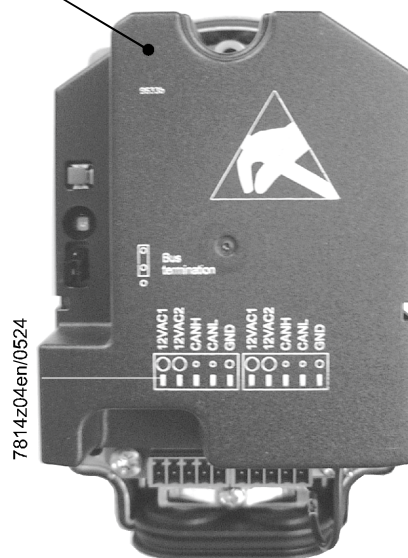

Addressing

Addressing (assignment of functions) defines whether the SQM4 shall operate as a

- fuel actuator
- air damper actuator, or
- auxiliary actuator,

and is made with the display and operating unit AZL5 (refer to Basic Documentation P7550) and the addressing button on the actuator, which is located under the housing cover. The correct assignment of actuator functions can be checked with the help of flashing LEDs.

Cable length Topology

For the maximum permissible cable length, refer to the Basic Documentation. Cabling must be strictly serial (**no branching permitted!**).

Electrical connection

The supplied RAST3.5 connector must be used with screw terminals for electrical connections. A tightening torque of 0.25 Nm must be observed for fitting the screw.

Standards and certificates



Note!

Only in conjunction with the basic unit LMV5 (see Basic Documentation P7550).



EAC Conformity mark (Eurasian Conformity mark)



China RoHS
Hazardous substances table:



Lifetime

The actuator has a designed lifetime* of 250,000 start cycles (OFF ⇌ ON ⇌ OFF) under load with the rated torque in the entire rotation angle range, which under normal operating conditions in heating mode corresponds to approx. 10 years of service (starting from the production date given on the nameplate). This is based on the endurance tests specified in the standard EN 298. A summary of the conditions has been published by the European Control Manufacturers Association (Afecon) (www.afecon.org).

The designed lifetime is based on use of the actuator according to the manufacturer's data sheet. After reaching the designed lifetime in terms of the number of burner startup cycles, or after the corresponding usage time, the actuator must be replaced by authorized personnel.

* The designed lifetime is not the warranty time specified in the Terms of Delivery.

Service notes

Replacement

When replacing an actuator, the following points must be checked and, if necessary, corrected:

- Addressing (assignment of functions)
- Bus termination
- Adjustment of the curvepoints of electronic fuel / air ratio control (e.g. with the LMV5)

Disposal notes

The SQM45/SQM48 contains electrical and electronic components and must not be disposed of together with domestic waste. Local and currently valid legislation must be observed.

Mechanical design

Housing	Die-cast aluminum lower housing. Housing cover made of impact-proof and heat-resistant plastic. Color of cover: Black				
Drive motor	Stepper motor				
Type of position feedback	<table border="1"> <thead> <tr> <th>Type</th> <th>Component part</th> </tr> </thead> <tbody> <tr> <td>SQM45.xxxB9 / SQM48.xxxB9</td> <td>Hall sensor</td> </tr> </tbody> </table>	Type	Component part	SQM45.xxxB9 / SQM48.xxxB9	Hall sensor
Type	Component part				
SQM45.xxxB9 / SQM48.xxxB9	Hall sensor				
Adjustment of switching points / position indication	In connection with the basic unit (e.g. LMV5): Via the display and operating unit AZL5 (refer to Basic Documentation P7550).				
Electrical connections	RAST3.5 terminals (supplied together with the AGG5.720 / AGG5.721).				
Gear train	SQM45: Spur gears made of plastic with small backlash and permanent lubrication. SQM48: Spur gears made of steel with small backlash and permanent lubrication.				
Drive shaft	Made of black-finished steel, ready fitted to the front of the gear train (SQM48 uses a drive shaft made of hardened steel).				
Mounting and fixing	The front of the gear train is used as the mounting surface. The actuator has 4 fixing holes and 1 elongated hole for the positioning pin. Alternatively, the actuator can be secured from the side of the controlling element with 3 self-tapping screws.				
Mounting kit ASK33.1	For mounting of SQM45.295x9 actuator on VKF1x butterfly valve, an ASK33.1 mounting kit is always required. The mounting kit consists of coupling with a preassembled mounting kit.				

Type summary

Actuators SQM4 When ordering, please give type references of actuator and accessories according to «Type summary».

Article number	Type	Drive shaft 1) no.	Running time (min.) for 90° s	Nominal output torque 3) 4) (max.) Nm	Holding torque 2) 3) 4) (max.) Nm	Radial bearing force (max.) N
S55451-D201-A100	SQM45.291B9	1	10	3	1.5	190
S55451-D202-A100	SQM45.295B9	5	10	3	1.5	190
S55451-D301-A100	SQM48.497B9	7	30	20	20	420
S55451-D302-A100	SQM48.697B9	7	60	35	35	800

Legend

- | | |
|--|--|
| 1) Refer to «Dimensions» | 4) Under nominal conditions 20 °C. Under extreme conditions (above +50 °C ambient temperature), the torque is about 15 % lower |
| 2) With operating voltage applied | |
| 3) Under nominal conditions 20 °C. Under extreme conditions (below -15 °C ambient temperature), the available torque is about 15 % lower | |

Accessories

Accessories must be ordered as separate items.



Proportional controlling element with mounting plate

VKPx

Proportional controlling element for mounting between threaded flanges in gas trains.
See Data sheet N7646.



Butterfly valve

VKF1x

Butterfly valves designed in intermediate flange design, for mounting into gas trains.
Refer to Data Sheet N7673.



Mounting plate

ASK33.1

Article no.: **BPZ:ASK33.1**

For mounting the SQM45.295x9 on the proportional controlling element VKPx.



Note

The required screws (3x M5 countersunk screws and 4x M5 screws) are included in the packaging for the ASK33.1.



CAN bus connecting cable

AGG5.641

Article no.: **BPZ:AGG5.641**

- Between LMV5 and system components
- Shielded 5-core cable
- Cable length 100 m
- $2 \times 1,25 \text{ mm}^2 + 1 \times 0,5 \text{ mm}^2 + 2 \times 0,25 \text{ mm}^2$



CAN bus connecting cable

AGG5.631

Article no.: **BPZ:AGG5.631**

- Between LMV5 and system components
- Shielded 5-core cable
- Cable length 100 m
- $3 \times 0,5 \text{ mm}^2 + 2 \times 0,25 \text{ mm}^2$



Separable cable entry (single pack, minimum order quantity of 50 units)

AGG5.812

Article no.: **BPZ:AGG5.812**



Note!

Specified connecting cables are mandatory!

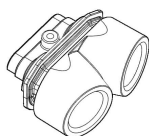

Cable entry (on request)

AGG6.822

Article no.: **S55854-Z618-A100**

- Cable entry from the SQM45/SQM48 to the LMV5 burner management system
- For installing the 1/2" NPT protective tube and the electrical supply lines
- Multipack
- Minimum order quantity of 50 units

Accessories (cont'd)

Accessories must be ordered as separate items.

Connector set

AGG5.720

Article no.: **BPZ:AGG5.720**

Standard connector set LMV5 for gas applications / oil applications with up to 3 actuators

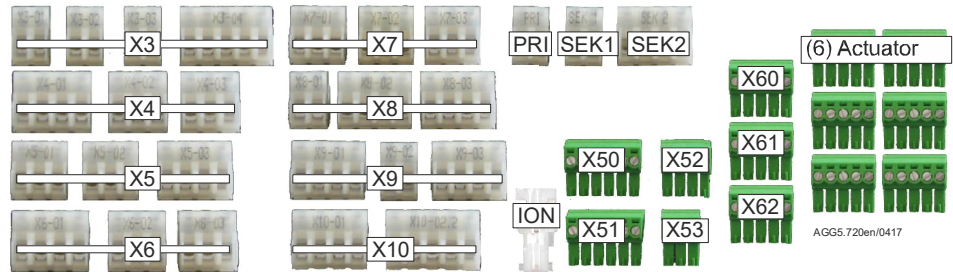

Connector set

AGG5.721

Article no.: **BPZ:AGG5.721**

Extension connector set LMV5 (complementing AGG5.720, all connector versions are covered)

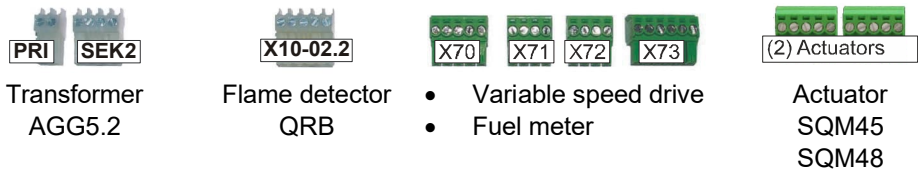

Example Single connectors

AGG9.853

Article no.: **BPZ:AGG9.853**



- Connector type RAST3.5
- 5-pole
- Packing unit 200 in total

Technical data

Actuator	Operating voltage	2 x 12 V~ via bus cable from the basic unit or via a separate transformer
	Operating frequency	50...60 Hz $\pm 6\%$
	Drive motor	Stepper motor
	Power consumption	
	• SQM45	9...15 VA
	• SQM48	26...34 VA
	On time	50 %, max. 3 min. continuously
	Angular adjustment	Max. 90°
	Mounting position	Optional
	Degree of protection	To EN 60529:1991 + A1:2000 + A2:2013, IP54, provided adequate cable entries are used
	Safety class	III according to EN 60730-1:2016 + A1:2019
	Mode of operation	Automatic regulator and control unit, type 2B
	External overload fuse	Max. 4 AT (slow) to DIN EN 60127-2
	Internal overload fuse	2.5 AT (slow), not replaceable (type-independent)
	Direction of rotation (when facing the shaft)	
	• Standard	Counterclockwise
	• Reverse	Clockwise
	Direction of rotation	Can be selected on the basic unit
	Reproducibility (typically in the show-room condition)	$\pm 0.2^\circ$ (when used with the basic unit LMV5...)
	Torques and holding torques	Refer to «Type summary»
	Running times	Refer to «Type summary» (can be selected on the basic unit)
	Drive shaft	Supplied as standard, not replaceable
	Weight	
	• SQM45...	Approx. 1 kg
	• SQM48...	Approx. 1.6 kg
	Temperature of the mounting surface	Max. 60 °C
	Life cycle	250,000 start cycles (CLOSE \Rightarrow OPEN \Rightarrow CLOSE) under load with the rated torque in the entire rotation angle range. 2,000,000 control cycles under load with 75% of rated torque in rotation angle range of 10°.
	Electrical connections	RAST3.5 terminals (for details, refer to the basic unit)
Ferrules	Matching the dia. of the stranded wire	
Cable entry	Insertable threaded cable glands for 2 x M16	
Wire cross-sectional area of the connecting wires	0.5...1.5 mm ²	

Technical data (cont'd)

Environment conditions	Storage	EN 60721-3-1:1997
	Climatic conditions	Class 1K3
	Mechanical conditions	Class 1M2
	Temperature range	-20...+60 °C
	Humidity	<95 % r.h.
	Transport	EN 60721-3-2:1997
	Climatic conditions	Class 2K2
	Mechanical conditions	Class 2M2
	Temperature range	-20...+70 °C
	Humidity	<95 % r.h.
	Operation	EN 60721-3-3:1995 + A2:1997
	Climatic conditions	Class 3K3
Mechanical conditions	Class 3M3	
Temperature range	-20...+60 °C	
Humidity	<95 % r.h.	
Installation altitude	Max. 2,000 m above sea level	



Warning!

**Condensation, formation of ice and ingress of water are not permitted!
If this is not observed, there is a risk of loss of safety functions.**

Function

The actuators SQM45 / SQM48 are of robust design and have a gear train with only small backlash. Control and position feedback take place via a bus system (CAN). The bus cable is also used for powering the actuators. The actuators are driven by stepper motors and can be positioned with a resolution of 0.1°. The characteristics and settings (running time, direction of rotation, limit positions) of the SQM4 are determined by the controlling basic unit (e.g. LMV5; for details, refer to the Basic Documentation P7550 of the LMV5). The running times of the associated controlling elements are varied by the basic unit depending on the burner's control phase (e.g. startup phase: short running time; operation: long running time).

Terminating resistor

At the end of the serial bus cabling, a terminating resistor must be fitted. For that purpose, a jumper must be set to BUS TERMINATION on the last actuator of the bus cable, which will activate the resistor. On all the other actuators, that jumper must be set to the other position (deactivated).

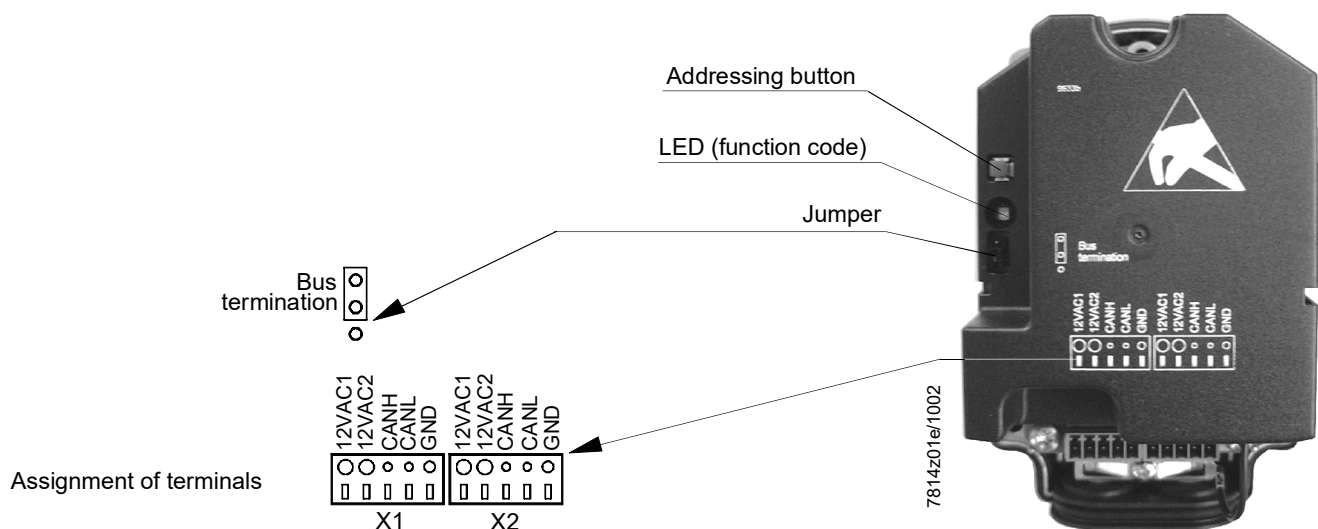

The 2 terminal blocks (X1 and X2) are identical.

Dimensions

Dimensions in mm

SQM45./ SQM48

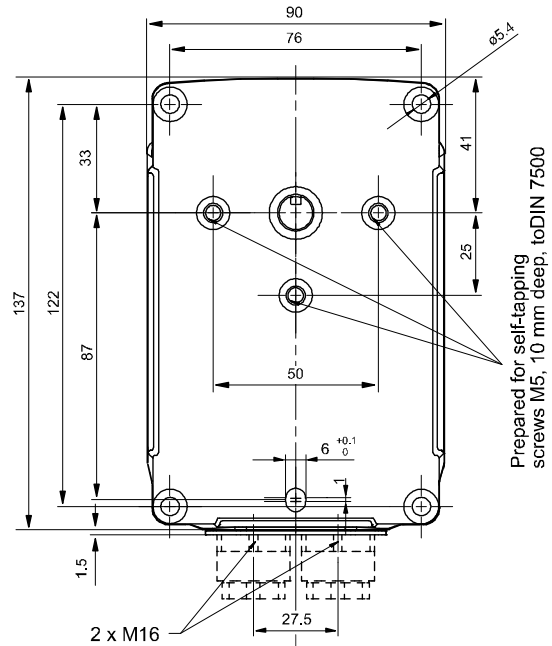
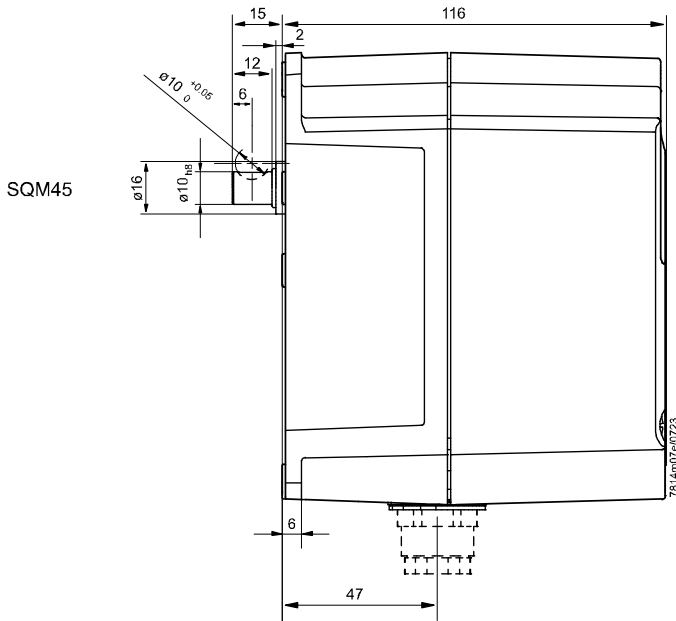

Choice of drive shaft lateral view

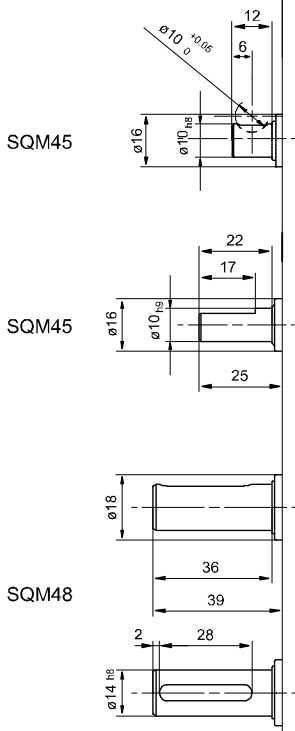

Drive shaft no. to "Type summary"

Choice of drive shaft vertical section

Groove for Woodruff key 3x3.7 DIN 6888

1

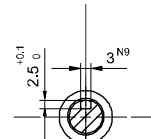

D-shaft

5

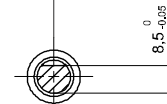

Groove for parallel key A5x3x28 to DIN 6885 T3

7

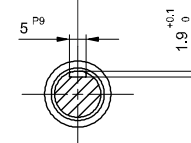

For mounting the SQM45 onto the VKPx proportional controlling element

Step 1:

- Loosen the screws (M5)
- Remove the plate in the direction of the arrow

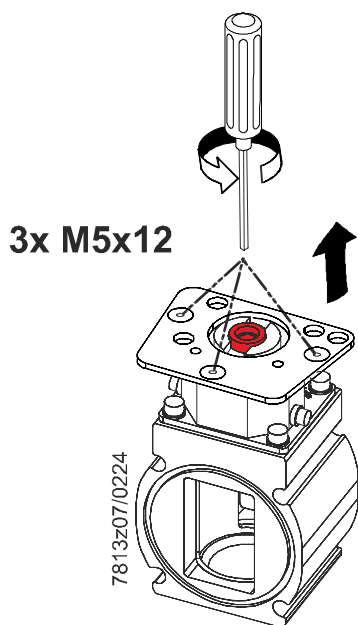

Step 2:

- Loosen the screws (1)
- Pull the plate in the direction of the arrow (2) and remove the reducing sleeve (3)

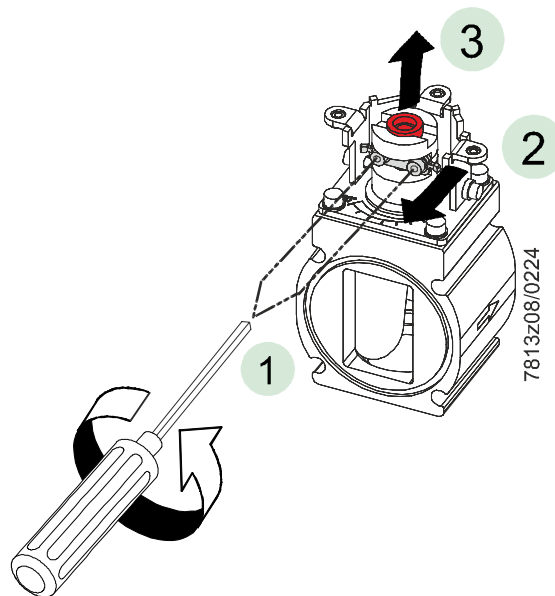

Step 3:

- Place the ASK33.1 mounting plate in the direction of the arrow
- Tighten the screws (M5)

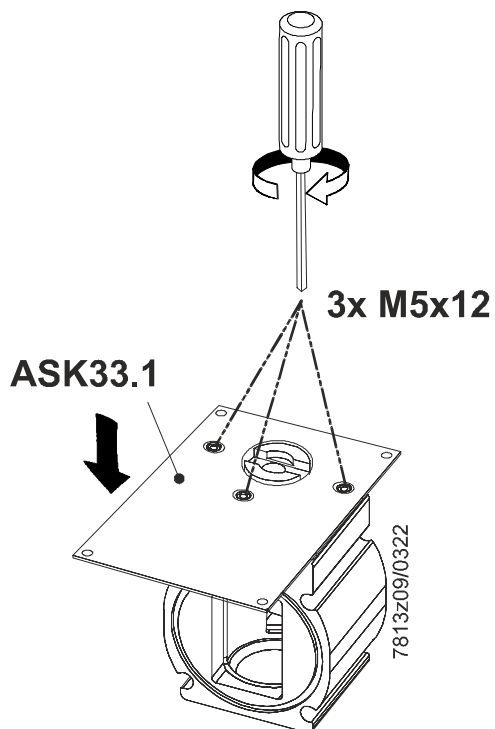

Step 4:

- Loosen the screws (1)
- Pull the plate in the direction of the arrow (2) and mount the SQM45

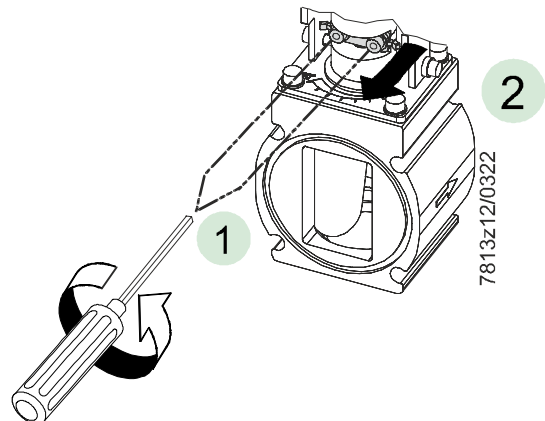

For mounting the SQM45 onto the VKPx proportional controlling element (continued)

Step 5:
Position the SQM45

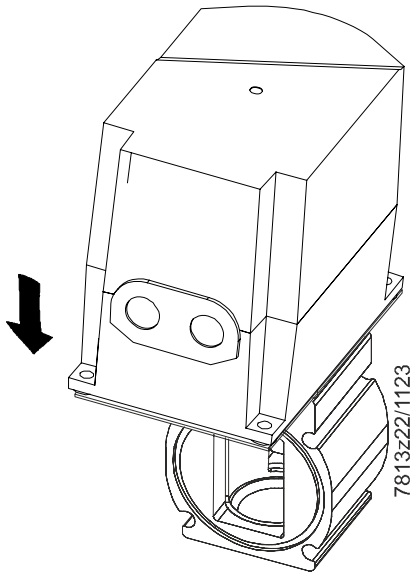

Step 6:
Tighten the screws

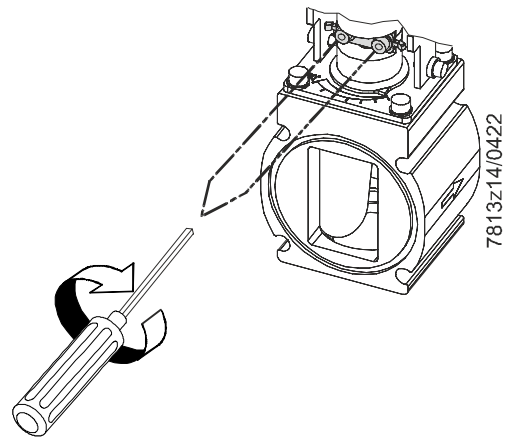

Step 7:
Screw the SQM45 to the mounting plate

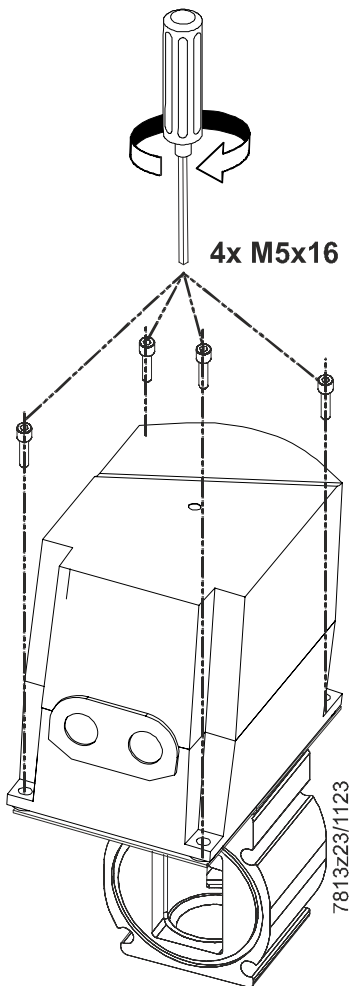

Fitting the SQM45/SQM48 onto the VKF1x butterfly valve

VKF10 / VKF11

VKF10/VKF11 contents

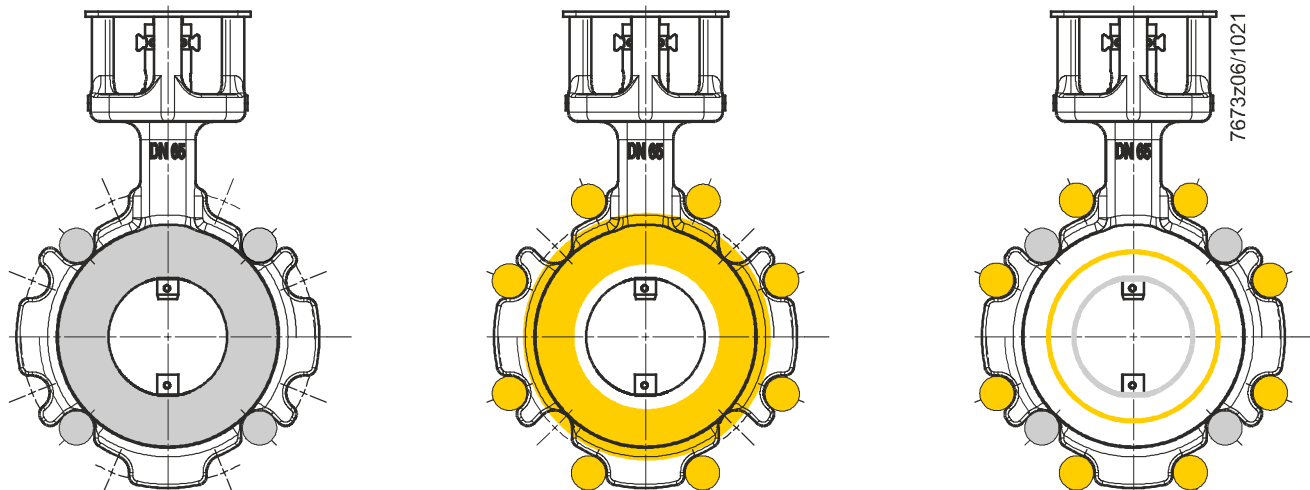
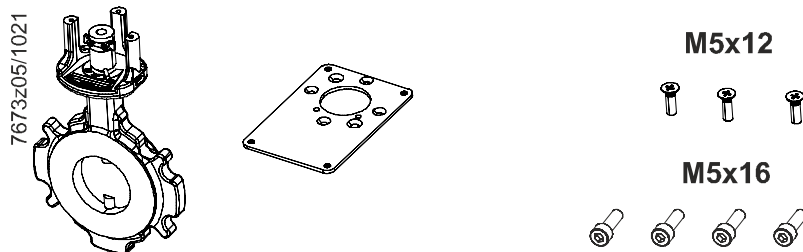

Nominal size	Swing thru	With mechanical stop	Suitable for flange size	Tightening torque	Mounting			
					DN ISO	DN ASME	DN+1 ISO	DN+1 ASME
32	VKF10.032	VKF11.032	DN32 + DN40	50 Nm	4 x M16	4 x ½	4 x M16	4 x ½
40	VKF10.040	VKF11.040	DN40 + DN50	50 Nm	4 x M16	4 x ½	4 x M16	4 x 5/8
50	VKF10.050	VKF11.050	DN50 + DN65	50 Nm	4 x M16	4 x 5/8	4 x M16	4 x 5/8
65	VKF10.065	VKF11.065	DN65 + DN80	50 Nm	4 x M16	4 x 5/8	8 x M16	4 x 5/8
80	VKF10.080	VKF11.080	DN80 + DN100	50 Nm	8 x M16	4 x 5/8	8 x M16	4 x 5/8
100	VKF10.100	VKF11.100	DN100 + DN125	80 Nm	8 x M16	8 x 5/8	8 x M16	8 x ¾
125	VKF10.125	VKF11.125	DN125 + DN150	160 Nm	8 x M16	8 x ¾	8 x M20	8 x ¾
150	VKF10.150	VKF11.150	DN150 + DN200	160 Nm	8 x M20	8 x ¾	12 x M20	8 x ¾
200	VKF10.200	VKF11.200	DN200	160 Nm	12 x M20	8 x ¾	---	---

Mounting position of the mounting plate

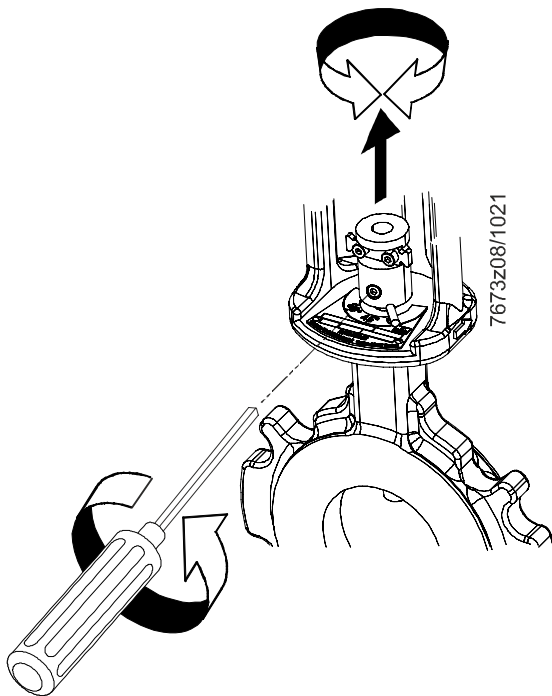
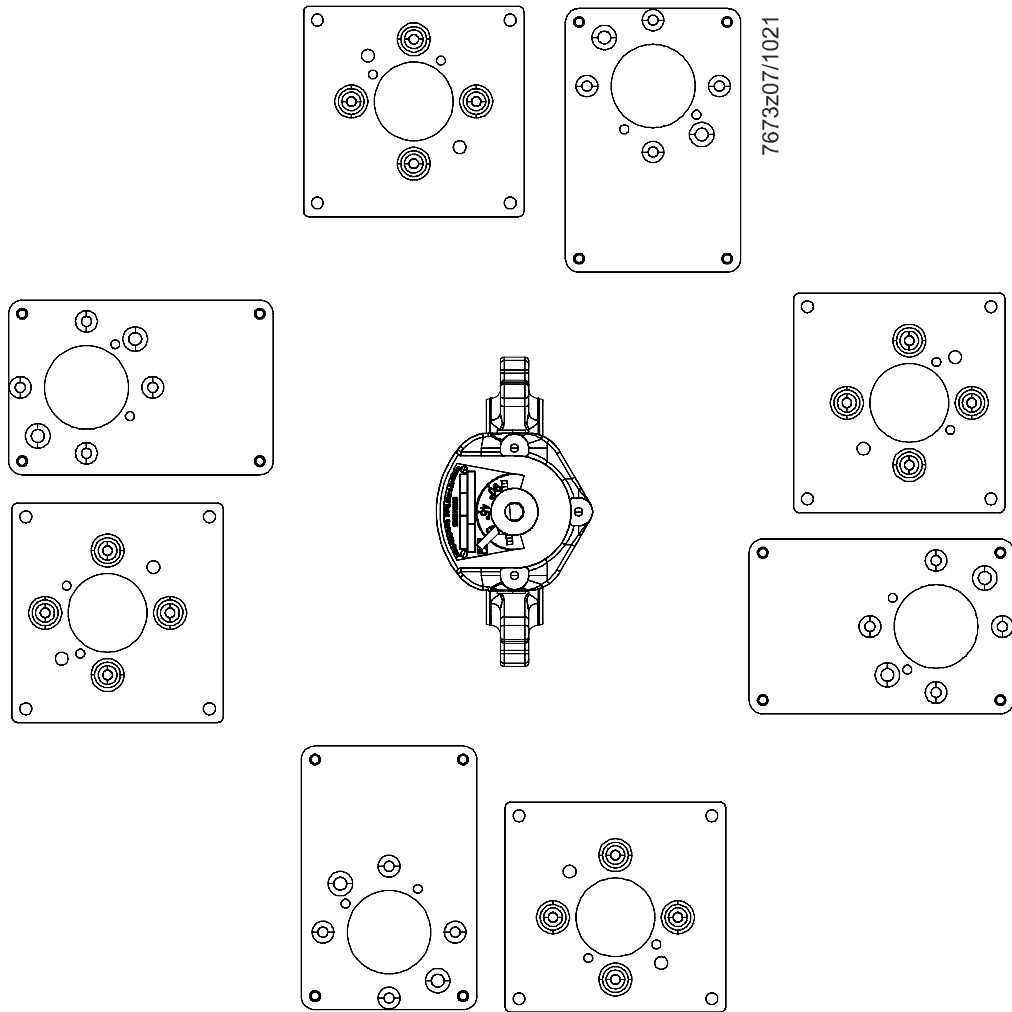

Step 1:

Loosen the screw. Align the clutch to suit the mounting position of the mounting plate. Tighten the screw again (max. 2 Nm)

Fitting the SQM45/SQM48 onto the VKF1x butterfly valve (continued)

Step 2:

- Place the ASK33.1 mounting plate in the direction of the arrow
- Tighten the screws (M5)

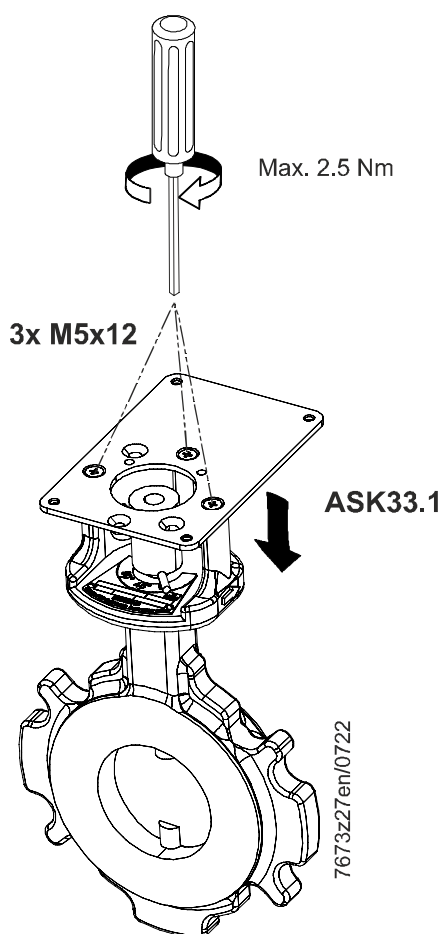

Step 3:

- Loosen the screws (1)
- Pull the plate in the direction of the arrow (2) so that the D-shaft of the SQM45/SQM48 can be pushed into the coupling. Then fit the SQM45/SQM48

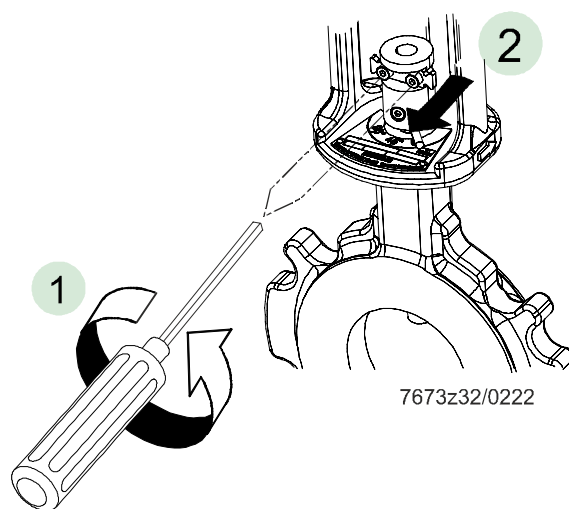

Fitting the SQM45/SQM48 onto the VKF1x butterfly valve (continued)

Step 4:

- Position the SQM45/SQM48 in the direction of the arrow (1)
- Screw the SQM45/SQM48 onto the mounting plate (2)

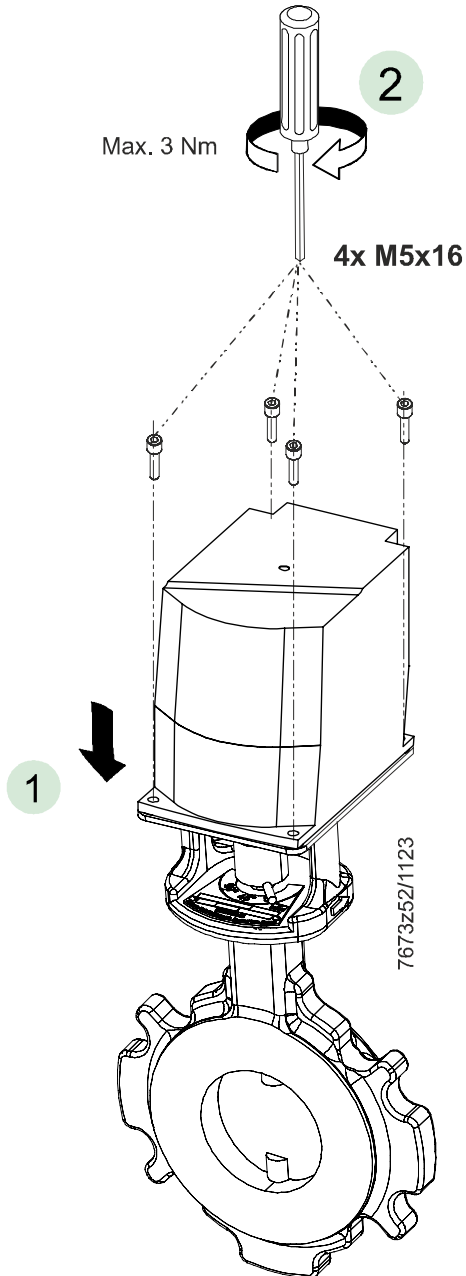

Step 5:

Tighten the screws (max. 2 Nm)

